

**TECHNICAL MANUAL**  
**UNIT, DIRECT SUPPORT, AND**  
**GENERAL SUPPORT MAINTENANCE MANUAL**  
**INCLUDING REPAIR PARTS AND SPECIAL TOOLS LIST**  
**THROUGH DEPOT LEVEL**  
**FOR**

**PALADIN MUZZLE VELOCITY SYSTEM M93 UPGRADED**

**PART NUMBER: 13002073**

**CAGE: 19200**

**NSN: 1290-01-503-4395 (EIC: 3TC)**

**LIN: R20826**

<p><b>DISTRIBUTION STATEMENT A:</b> Approved for public release; distribution is unlimited.</p>
---

**HEADQUARTERS, DEPARTMENT OF THE ARMY**  
**31 OCTOBER 2000**

---



## SAFETY SUMMARY

---

### DEFINITIONS

The following definitions apply to the warnings, cautions, and notes used throughout this manual:

**WARNING**

Operating procedures, techniques, etc., that may result in personal injury or loss of life if not carefully followed.

**CAUTION**

Operating procedures, techniques, etc., that may result in damage to equipment if not carefully followed.

**NOTE**

Operating procedures, techniques, etc., that are considered essential to emphasize.

The following are general safety precautions that are not related to any specific procedures and therefore do not appear elsewhere in this publication. These are recommended precautions that personnel must understand and apply during many phases of operation and maintenance.

### KEEP AWAY FROM LIVE CIRCUITS

Operating personnel must at all times observe all safety regulations. Do not replace components inside the equipment with the voltage supply turned on. Under certain conditions, dangerous potentials may exist when the power control is in the off position due to charges retained by capacitors. To avoid casualties, always remove power and discharge and ground a circuit before touching it.

### DO NOT SERVICE OR ADJUST ALONE

Under no circumstances should any person service or adjust the equipment except in the presence of someone who is capable of rendering aid.

### RESUSCITATION

Personnel working with or near high voltages should be familiar with modern methods of resuscitation. Such information may be obtained from the Bureau of Medicine and Surgery.

**ARMY TM 9-1290-365-24&P**

The following warnings and cautions appear in the text of this manual and are repeated here for emphasis.

**WARNING**

Electrical power shall be removed (off) before disconnecting or connecting electrical connectors or connections, or removing or installing units or components. Inadvertent contact with voltages present may be fatal. Connector pins may be damaged by arcing.

**WARNING**

Use solvent in a well-ventilated area. Avoid breathing vapors. Keep away from flame.

**WARNING**

Use methylethylketone (MEK) in a well-ventilated area. Avoid breathing vapors. Keep away from flame.

**WARNING**

Certain circuits operate with high voltages. Ensure that test equipment is off prior to any replacement.

**WARNING**

Use RTV732 sealant in well-ventilated area. Prevent eye and skin contact. Avoid breathing vapors.



**CAUTION**

This equipment contains assembly's subject to damage by electrostatic discharge. Use approved grounding procedures before touching, removing, or inserting circuit card assemblies.

**CAUTION**

Do not immerse electronic parts in solvent.



CAUTION

The transceiver is susceptible to electrostatic discharge. Handling of the transceiver electronic assembly and transceiver should be performed at a static-free station and with grounded measurement instruments.

#### EXPLANATION OF HAZARD SYMBOLS



The symbol of drops of a liquid onto a hand shows that the material will cause burns or irritation of human skin or tissue.



The symbol of a human figure in a cloud shows that vapors of the material present a danger to your life or health.



The symbol of a person wearing goggles shows that the material will injure your eyes.



The symbol of a flame shows that the material can ignite and burn you.



The symbol shows that the item is sensitive to electrostatic discharge (ESD).



CHANGE  
NO. 1

TECHNICAL MANUAL

UNIT, DIRECT SUPPORT, AND  
GENERAL SUPPORT MAINTENANCE  
MANUAL INCLUDING REPAIR PARTS AND SPECIAL TOOLS LIST  
THROUGH DEPOT LEVEL  
FOR  
PALADIN MUZZLE VELOCITY SYSTEM M93 UPGRADED

PART NUMBER: 13002073

NSN: 1290-01-503-4395 (EIC: 3TC) LIN: R20826

LIN: Z33756

The purpose of this change is to update TM 9-1290-365-24&P:

1. Remove old pages and insert new pages as indicated below.
2. New or changed material is indicated by a vertical bar in the margin of the page.
3. Added or revised illustrations are indicated by a vertical bar adjacent to the illustration or miniature pointing hands in the affected areas.
4. Remove the old pages and insert the new page as indicated below:

Remove Pages

None  
i thru viii  
1-1 and 1-2  
1-21 and 1-22  
3-1/(3-2 blank)  
3-5 and 3-6  
3-13 thru 3-16  
3-21 thru 3-23/(3-24 blank)  
3-31 through 3-33/(3-34 blank)  
6-1 and 6-2  
B-1 through B-6  
C-9/(C-10 blank)  
C1-1 thru C2-2  
C6-1 thru C7-2  
Figure C-10 thru C10-1/(blank)  
I-13 and I-14  
D-1 and D-2  
D-7 thru D-26  
D-37 thru D-40  
D-75 and D-76  
D-81 thru D-90

Insert Pages

A/(B blank)  
i thru viii  
1-1 and 1-2  
1-21 and 1-22  
3-1/(3-2 blank)  
3-5 and 3-6  
3-13 thru 3-16  
3-21 thru 3-23/(3-24 blank)  
3-31 through 3-33/(3-34 blank)  
6-1 and 6-2  
B-1 through B-6  
C-9/(C-10 blank)  
C1-1 thru C2-2  
C6-1 thru C7-2  
Figure C-10 thru C10-1/(blank)  
I-13 and I-14  
D-1 and D-2  
D-7 thru D-26  
D-37 thru D-40  
D-75 and D-76  
D-81 thru D-90

**TM 9-1290-365-24&P**

D-93 thru D-96  
D-103 and D-104  
FO-1/(FO-2 blank) thru FO-19/(FO-20 blank)  
Cover

D-93 thru D-96  
D-103 and D-104  
FO-1/(FO-2 blank) thru FO-29/(FO-30 blank)  
Cover

5. File this sheet in the front of the manual for reference purposes.

By Order of the Secretary of the Army:

Official:



SANDRA R. RILEY  
*Administrative Assistant to the  
Secretary of the Army*

0512601

PETER J. SCHOOMAKER  
*General, United States Army  
Chief of Staff*

**DISTRIBUTION:** To be distributed in accordance with the Initial Distribution Number (IDN) 372507 requirements for TM 9-1290-365-24&P.



INSERT LATEST CHANGED PAGES.  
DESTROY SUPERSEDED PAGES

**LIST OF EFFECTIVE PAGES**

Note: The portion of the text affected by the changes is indicated by a vertical line in the outer margin of the page. Changes to illustrations are indicated by miniature pointing hands. Changes to wiring diagrams are indicated by shaded areas.

Date of issue for original and changed pages are:

Original           0                   31 October 2000  
Change            1                   23February2006

TOTAL NUMBER OF PAGES IN THIS PUBLICATION IS 731, CONSISTING OF THE FOLLOWING:

Page No.	*Change No.	Page No.	*Change No.	Page No.	*Change No.
Cover	1	B-1 – B-4	1	D-76	1
Blank	0	B-5 – B-6	1	D-77 – D-80	0
Change 1 Errata Added (2)	1	C-1 – C-8	0	D-81	1
SS-1 – SS-3	0	C-9 –	1	D-82	0
SS-4 blank	0	C-10 blank	0	D-83 – D-89	1
i	1	Figure C-1	0	D-90 – D-92	0
ii – iii	0	C1-1 – Figure C-2	1	D-93	1
iv – vii	1	C2-1	1	D-94	0
viii – ix	0	C2-2	0	D-95 – D-96	1
x blank	0	Figure C-3	0	D-97 – D-102	0
1-1	0	Figure C-4	0	D-103	1
1-2	1	C4-1 – C4-4	0	D-104 – D-119	0
1-3 – 1-20	0	Figure C-5	0	D-120 blank	0
1-21 – 1-22	1	C5-1	0	E-1 – E-3	0
1-23 – 1-25	0	Figure C-6	0	E-4 blank	0
1-26 blank	0	C6-1	1	G-1 – G-6	0
2-1	0	Figure C-7	1	FO-1– FO-30 blank	1
2-2 blank	0	C7-1	1		
3-1	1	C7-2	0		
3-2 blank	0	Figure C-8	0		
3-3 – 3-4	0	C8-1	0		
3-5	1	Figure C-9	0		
3-6 – 3-12	0	C9-1	0		
3-13	1	Figure C-10	1		
3-14 – 3-15	0	C10-1	1		
3-16	1	Figure C-11	0		
3-17 – 3-20	0	C11-1	0		
3-21	1	BULK-1	0		
3-22	0	I-1 – I-13	0		
3-23	1	I-14	1		
3-24 blank	0	I-15	0		
3-25 – 3-31	0	D-1	1		
3-32 – 3-33	1	D-2 – D-6	0		
3-34 blank	0	D-7	1		
4-1 – 4-2	0	D-8	0		
5-1	0	D-9 – D-26	1		
5-2 blank	0	D-27 – D-37	0		
6-1 – 6-2	1	D-38 – D-39	1		
A-1 – A-2	0	D-40 – D-75	0		

**Change 1    A/(B blank)**

\*Zero in this column indicates an original page



Chapter	Page
SAFETY SUMMARY .....	SS-1
LIST OF ILLUSTRATIONS .....	v
LIST OF TABLES .....	vii
FOREWORD .....	viii
<b>1 GENERAL INFORMATION AND SYSTEM DESCRIPTION .....</b>	<b>1-1</b>
<b>Section I General Information .....</b>	<b>1-1</b>
Scope .....	1-2
Equipment Name and Part Numbers .....	1-2
Purpose of Equipment .....	1-2
Maintenance Forms and Procedures .....	1-2
Safety, Care, and Handling .....	1-5
Electrostatic Discharge (ESD) Awareness .....	1-5
Typical Prime Charge Sources .....	1-5
Prime Charge Carriers .....	1-5
Items to Avoid .....	1-5
Handling Unpackaged ESD Sensitive Items .....	1-5
Packaging and Labeling ESD Sensitive Items/Assemblies .....	1-5
Types of ESD Sensitive Devices .....	1-6
Army Adopted Configuration .....	1-6
Precautions within 20-foot (6-meter) Distance .....	1-6
Precautions within 50-foot (15-meter) Distance .....	1-6
Chairs .....	1-7
Corrosion Prevention and Control .....	1-7
Destruction of Army Materiel to Prevent Enemy Use .....	1-7
Decontamination of Components .....	1-7
Reporting Equipment Improvement Recommendations (EIR) .....	1-7
<b>Section II Equipment Description .....</b>	<b>1-8</b>
Equipment Features .....	1-8
Equipment Performance .....	1-8
Physical Characteristics .....	1-9
Power Requirements .....	1-9
Environmental Information .....	1-9
Principles of Operation .....	1-10
Muzzle Velocity Measurement and, Calculation .....	1-10
System Interconnection .....	1-11

TABLE OF CONTENTS (Cont.)

Chapter	Page
<b>Section III Component Description</b> .....	1-13
Components .....	1-13
Transceiver Assy .....	1-13
Mounting Bracket .....	1-13
Power and Data Cables.....	1-13
Transceiver Assy.....	1-14
General Description .....	1-14
RF Section .....	1-15
Doppler Amplifier.....	1-15
Power Supply Module .....	1-16
Muzzle Velocity Processor (MVP) .....	1-17
Mechanical Construction .....	1-20
RF Section .....	1-20
Back Cover Assembly .....	1-20
Mounting Bracket .....	1-23
Power and Data Cables.....	1-24
1553 Termination .....	1-25
<b>2 OPERATING INSTRUCTIONS</b> .....	2-1
General.....	2-1
MV Min/Max Range.....	2-1
<b>3 MAINTENANCE INSTRUCTIONS</b> .....	3-1
General Instructions .....	3-3
Power and Data Cable (0.75-Meter), P/N 12979004.....	3-7
Power and Data Cable (5-Meter), P/N 12979005.....	3-13
1553 Termination, P/N 12979006.....	3-25
Bracket Assembly, P/N 12979003.....	3-29
Transceiver Assembly, P/N 12979002.....	3-33
<b>4 UNPACKING AND INSTALLATION</b> .....	4-1
General.....	4-1
Unpacking .....	4-1
Installation .....	4-1
Installation of Transceiver Assy on Gun .....	4-2
System Interconnection .....	4-2
<b>5 PREPARATION FOR SHIPMENT</b> .....	5-1
General.....	5-1
Shipping M93 MVS In Crates .....	5-1
Packing and Shipping M93 Units and Parts.....	5-1

TABLE OF CONTENTS (Cont.)

Chapter	Page
<b>6 STORAGE</b> .....	6-1
Preparation For Storage .....	6-1
Environment.....	6-1
Return To Service.....	6-1
Shipping .....	6-2
<b>APPENDIX A - REFERENCES</b> .....	A-1
General.....	A-1
Forms.....	A-1
Field Manuals .....	A-1
Technical Manuals .....	A-1
Miscellaneous Publications.....	A-2
<b>APPENDIX B - MAINTENANCE ALLOCATION CHART (MAC)</b> .....	B-1
General.....	B-1
Maintenance Functions .....	B-1
Explanation of Columns In The MAC - Section II .....	B-2
Explanation of Columns In Tool And Test Equipment Requirements - Section III.....	B-3
Explanation of Columns In Remarks- Section IV.....	B-3
Maintenance Allocation Chart .....	B 5
<b>APPENDIX C - REPAIR PARTS AND SPECIAL TOOLS LIST</b> .....	C-1
<b>Section I Introduction</b> .....	C-1
General.....	C-1
RPSTL Description.....	C-1
Explanation of Columns (Sections II And III) .....	C-2
Explanation of Columns (Section IV) .....	C-6
How to Locate Repair Parts.....	C-8
<b>Section II Parts List</b> .....	C-9
<b>Section III Special Support Equipment</b> .....	C11-1
<b>Section IV Cross-Reference Indexes</b> .....	I-1

TABLE OF CONTENTS (Cont.)

Chapter	Page
<b>APPENDIX D OVERHAUL PROCEDURES</b> .....	D-1
General .....	D-1
Technical Support Requirements.....	D-2
Preshop Analysis .....	D-3
Transceiver Assembly, P/Ns AY6707292-3, AY6707292-4 and AY6707292-5....	D-7
Doppler Amplifier Circuit Card Assembly (CCA), P/N AY67065566-0 .....	D-49
Power Supply Module, P/N AY6707291-0 .....	D-63
Muzzle Velocity Processor (MVP) Circuit Card Assembly (CCA), P/N's AY6707288-3, AY6707288-4, and AY67010314 .....	D-81
Electro-Magnetic Interference (EMI) Filter Module, P/ns AY6707289-1 and AY6707289-3 .....	D-107
Microwave Test Equipment, Description and Calibration .....	D-113
<b>APPENDIX E GLOSSARY</b> .....	E-1
Abbreviations and Acronyms .....	E-1
Special Terms .....	E-3
<b>APPENDIX F EXPENDABLE AND DURABLE ITEMS LIST</b> .....	F-1
Scope.....	F-1
Explanation of Columns .....	F-1
<b>APPENDIX G FORMS</b> .....	G-1
<b>FOLDOUT DIAGRAMS</b> .....	FO-1

**LIST OF ILLUSTRATIONS**

<b>Figure</b>	<b>Title</b>	<b>Page</b>
1-1	M93 MVS Components .....	1-3
1-2	M93 MVS Interconnection .....	1-12
1-3	Transceiver Assy Simplified Block Diagram.....	1-14
1-4	Doppler Amplifier Module Simplified Block Diagram .....	1-15
1-5	Power Supply Module Simplified Block Diagram .....	1-16
1-6	MVP Simplified Block Diagram.....	1-18
1-7	Transceiver RF Section (Part of Transceiver Assy, P/N 13002074) .....	1-21
1-8	Transceiver Back Cover Assembly (Part of Transceiver Assy, P/N 13002074) .....	1-22
1-9	Mounting Bracket Assy, P/N 12979003.....	1-23
1-10	Power and Data Cables .....	1-24
1-11	1553 Termination, P/N 12979006 .....	1-25
3-1	Power and Data Cable (0.75-Meter), P/N 12979004 .....	3-11
3-2	Power and Data Cable (0.75-Meter), P/N 12979004, Connector Pin Locations.....	3-12
3-3	Power and Data Cable (0.75-Meter), P/N 12979004, Wiring Diagram.....	3-12
3-4	Power and Data Cable (5-Meter), P/N 12991852 .....	3-16
3-5	Power and Data Cable Test Setup.....	3-18
3-6	Power and Data Cable Tester, P/N AY6707984-0, Schematic Diagram.....	3-19
3-7	Power and Data Cable (5-Meter), P/N 12991852, Wiring Diagram.....	3-21
3-8	Power and Data Cable (5-Meter), P/N 12991852, Connector Pin Locations .....	3-21
3-9	1553 Stub (Part of Power and Data Cable (5-Meter), P/N 12991852).....	3-23
3-10	1553 Termination, P/N 12979006 .....	3-28
3-11	Bracket Assembly, P/N 12979003.....	3-31
3-12	Bracket Assembly, P/N 12979003, Removal and Installation .....	3-32
4-1	M93 MVS Installation .....	4-2
C-1	M93 Muzzle Velocity System, P/N 13002073 .....	C1-1
C-2	Transceiver Assy, P/N 13002074.....	C2-1
C-3	Power Supply Module, P/N AY6707291-0 .....	C3-1
C-4	Power Supply CCA, P/N 6707290-0 .....	C4-1
C-5	Doppler Amplifier CCA, P/N AY6706566-0 .....	C5-1
C-6	EMI Filter Module, P/N AY6707289-1 .....	C6-1
C-7	Muzzle Velocity Process, P/N AY6707288-3 .....	C7-1
C-8	Bracket Assembly, P/N 12979003 .....	C8-1
C-9	Power and Data Cable (0.75 Meter), P/N 12979004 .....	C9-1
C-10	Power and Data Cable (5 Meter), P/N 12991852 .....	C10-1
C-11	Special Support Equipment.....	C11-1

LIST OF ILLUSTRATIONS (Cont.)

Figure	Title	Page
D-1	Transceiver Assembly, AY6707292-3.....	D-12
D-2	Transceiver Assembly, AY6707292-4.....	D-15
D-3	Transceiver Assembly, AY6707292-5.....	D-19
D-4	RF Cable, P/N WA6706563.....	D-21
D-5	Transceiver Assembly Power Supply and Transmitted Frequency Test Setup.....	D-28
D-6	Transceiver Assembly Transmitted Power Test Setup.....	D-29
D-7	Transceiver Assembly Sensitivity Test Setup.....	D-30
D-8	Transceiver Assembly RF Section Test Fixture.....	D-31
D-9	Transceiver Assembly RF Section Test Fixture Schematic.....	D-32
D-10	Transceiver Assembly RF Section Test Cable.....	D-33
D-11	Transceiver Assembly Functional Test Setup.....	D-38
D-13	1553 Bus Simulator Schematic.....	D-39
D-15	Test Doppler Simulator Schematic.....	D-40
D-17	1553 Bus Simulator Cable.....	D-41
D-18	Test Cable.....	D-42
D-19	Communication Test Cable.....	D-43
D-20	Doppler Amplifier CCA, AY6706566-0, Components Location.....	D-51
D-21	Doppler Amplifier CCA Test Setup.....	D-52
D-22	Doppler Amplifier CCA Test Fixture.....	D-53
D-23	Doppler Amplifier CCA Test Fixture Schematic.....	D-54
D-24	Doppler Amplifier CCA, AY6706566-0, Troubleshooting Flowchart.....	D-58
D-25	Power Supply Module.....	D-66
D-27	Power Supply Module Test Fixture.....	D-70
D-28	Power Supply Module Test Fixture Schematic.....	D-71
D-29	Power Supply Module Adjustment Setup.....	D-74
D-30	MVP CCA, AY6707288-3.....	D-85
D-31	MVP CCA, AY6707288-4.....	D-87
D-32	MVP CCA, AY670010314.....	D-89
D-34	MVP CCA Test Fixture.....	D-91
D-35	MVP CCA Test Fixture Schematic.....	D-92
D-36	Signal Shape on Oscilloscope.....	D-94
D-37	DSP U34 Pinout to Schematic Cross Reference – Bottom View.....	D-103
D-38	EMI Filter Module, AY6707289-1.....	D-109
D-39	EMI Filter Module, AY6707289-3.....	D-110
D-40	Microwave Measurement Equipment Connection.....	D-115
D-41	Microwave Measurement Equipment Calibration Schematic.....	D-117
FO-1	Transceiver Harness Schematic Diagram.....	FO-3
FO-2	Doppler Amplifier CCA, P/N AY6706566-0, Schematic Diagram.....	FO-5
FO-3	Muzzle Velocity Processor CCA, P/N AY6707288-3, Schematic Diagram.....	FO-7
FO-4	Power Supply Module, P/N AY6707291-0, Schematic Diagram.....	FO-9
FO-5	Power and Data Cable (5-Meter), P/N 12991852, Schematic Diagram.....	FO-11



LIST OF TABLES

Table	Title	Page
1-1	M93 MVS Equipment Name and Part Numbers.....	1-2
1-2	Means of Static Charge Generation.....	1-5
1-3	Device Type And Range of ESD Susceptibility (Volts) .....	1-6
3-1	Maintenance Schedule.....	3-3
3-2	Materials Required .....	3-4
3-3	MVS/AFCS Interface Troubleshooting .....	3-5
3-4	Test Equipment And Special Tools Required .....	3-7
3-5	Materials Required .....	3-8
3-6	Power and Data Cable (5-Meter), P/N 12991852, Wiring Table .....	3-10
3-7	Test Equipment And Special Tools Required .....	3-13
3-8	Materials Required .....	3-14
3-9	Fault Isolation Table.....	3-20
3-10	Test Equipment And Special Tools Required .....	3-25
3-11	Materials Required .....	3-26
3-12	Special Tools Required .....	3-29
3-13	Materials Required.....	3-29
D-1	Preshop Analysis Checklist.....	D-5
D-2	Test Equipment and Special Tools Required.....	D-8
D-3	Materials Required .....	D-9
D-4	M93 Transceiver Assembly Configurations.....	D-10
D-5	Transceiver Assembly RF Section Test Data Sheet .....	D-36
D-6	Transceiver Assembly Functional Test Data Sheet .....	D-45
D-7	Test Equipment and Special Tools Required.....	D-49
D-8	Materials Required .....	D-50
D-9	Doppler Amplifier CCA Test Data Sheet .....	D-56
D-10	Test Equipment and Special Tools Required.....	D-63
D-11	Materials Required .....	D-64
D-12	Power Supply Module Test Data Sheet .....	D-73
D-13	Resistors Selection List.....	D-75
D-14	Power Supply Module Adjustment Data Sheet .....	D-76
D-15	Test Equipment and Special Tools Required.....	D-82
D-16	Materials Required .....	D-82
D-17	MVP CCQ Configurations .....	D-83
D-18	MVP CCA Test Data Sheet.....	D-97
D-19	MVP CCA AY6707288-3 Programmed Components.....	D-103
D-20	MVP CCA AY6707288-4 Programmed Components.....	D-104
D-21	MVP CCA AY67010314 Programmed Components.....	D-104
D-22	Test Equipment and Special Tools Required.....	D-107
D-23	EMI Filter Module P/N AY6707289-1 and AY6707289-3 Continuity Test Data Sheet .....	D-111
D-24	Standard Measurement Equipment .....	D-114
D-25	Microwave Measurement Equipment.....	D-114
D-26	MME Calibration Data Sheet.....	D-119

## **FOREWORD**

---

### **PURPOSE OF THIS MANUAL**

This manual provides maintenance instructions for the M93 Paladin Muzzle Velocity System (MVS) to enable personnel to perform the various tasks necessary to maintain the system.

### **CONTENTS OF THIS MANUAL**

This manual contains the following chapters:

Chapter 1	-	General Information and System Description
Chapter 2	-	Operating Instructions
Chapter 3	-	Maintenance Instructions
Chapter 4	-	Unpacking and Installation
Chapter 5	-	Preparation for Shipment
Chapter 6	-	Storage
Appendix A	-	References
Appendix B	-	Maintenance Allocation Chart
Appendix C	-	Repair Parts and Special Tools List
Appendix D	-	Overhaul Procedures
Appendix E	-	Glossary
Appendix F	-	Expendable and Durable Items List
Appendix G	-	Forms
Foldout Diagrams		

### **USE OF THIS MANUAL**

The Table of Contents indicates chapter, section, paragraph title, and page number to facilitate location of information. Illustrations, tables, and diagrams are located throughout the manual to supplement the text material. Schematics and wiring diagrams are included to facilitate parts replacement, troubleshooting, and testing. The list of illustrations and tables indicates the number, title, and location.

### **RELATED PUBLICATIONS**

Refer to Appendix A for a list of related publications.

### **COMMON TOOLS AND EQUIPMENT**

For authorized common tools and equipment, refer to the Modified Table of Organization and Equipment (MTOE), CTA 50-970 or CTA 8-100, as applicable to your unit.

### **SPECIAL TOOLS AND SUPPORT EQUIPMENT**

There are no special tools required for the repair of the M93 MVS. Support equipment required and authorized for repair of the M93 MVS is listed in the maintenance allocation chart (MAC) (Appendix B).

### **TEST, MEASUREMENT, AND DIAGNOSTIC EQUIPMENT (TMDE)**

TMDE required and authorized for repair of the M93 MVS are listed in the maintenance allocation chart (MAC) (Appendix B).

### **REPAIR PARTS**

Repair parts are listed and illustrated in Appendix C of this manual.



**CHAPTER 1**

**GENERAL INFORMATION AND SYSTEM DESCRIPTION**

**CHAPTER CONTENTS**

		<b>Page</b>
Section I	General Information.....	1-1
Section II	Equipment .....	1-8
Section III	Component Description.....	1-13

**SECTION I. GENERAL INFORMATION**

**SECTION CONTENTS**

<b>Subject.....</b>	<b>Page</b>
Scope.....	1-2
Equipment Name and Part Numbers .....	1-2
Purpose of Equipment .....	1-2
Maintenance Forms and Procedures.....	1-2
Safety, Care, and Handling.....	1-5
Electrostatic Discharge (ESD) Awareness.....	1-5
Typical Prime Charge Sources .....	1-5
Prime Charge Carriers .....	1-5
Items to Avoid .....	1-5
Handling Unpackaged ESD Sensitive Items.....	1-5
Packaging and Labeling ESD Sensitive Items/Assemblies .....	1-5
Types of ESD Sensitive Devices .....	1-6
Army Adopted Configuration.....	1-6
Precautions within 20-foot (6-meter) Distance.....	1-6
Precautions within 50-foot (15-meter) Distance.....	1-6
Chairs.....	1-7
Corrosion Prevention and Control.....	1-7
Destruction of Army Materiel to Prevent Enemy Use.....	1-7

<b>Subject</b>	<b>Page</b>
Decontamination of Components.....	1-7
Reporting Equipment Improvement Recommendations (EIR).....	1-7

**1.1 SCOPE.**

This manual provides maintenance instructions for the M93 Paladin Muzzle Velocity System.

**1.2 EQUIPMENT NAME AND PART NUMBERS.**

Equipment names, part numbers, and military nomenclature are provided in Table 1-1.

*Table 1-1. M93 MVS Equipment Name and Part Numbers*

<b>Component</b>	<b>Part Number</b>	<b>Military Nomenclature</b>
Transceiver	13002074	Antenna Transceiver Assembly
Power and Data Cable (0.75-Meter)	12979004	Power and Data Cable (0.75-Meter)
Power and Data Cable (5-Meter)	12991852	Power and Data Cable (5-Meter)
Mounting Bracket	12979003	Mounting Bracket
1553 Termination	12979006	1553 Termination

**1.3 PURPOSE OF EQUIPMENT**

The purpose of the M93 (Figure 1-1) is to provide an accurate muzzle velocity reading for a projectile fired from a gun. The M93 MVS is designed to communicate measured projectile velocities, via a MIL-STD-1553B Data Bus to the M109A6 Paladin Automatic Fire Control System. This information can be used to provide a reasonable estimate of the average muzzle velocity for rounds to be fired for a new mission, thereby improving the possibility of a first-round hit on the target.

**1.4 MAINTENANCE FORMS AND PROCEDURES.**

Department of the Army forms and procedures used for equipment maintenance will be those prescribed by DA PAM 750-8, the Army Maintenance Management System (TAMMS), as contained in the Maintenance Management Update. A listing of maintenance forms is provided in Appendix A.

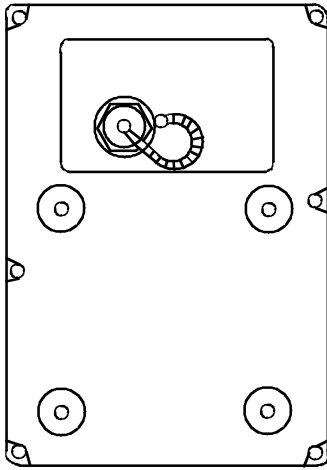

**TRANSCEIVER  
(REAR VIEW)**

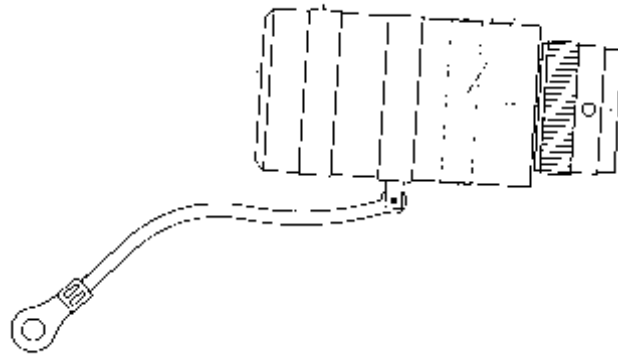

**1553 TERMINATION**

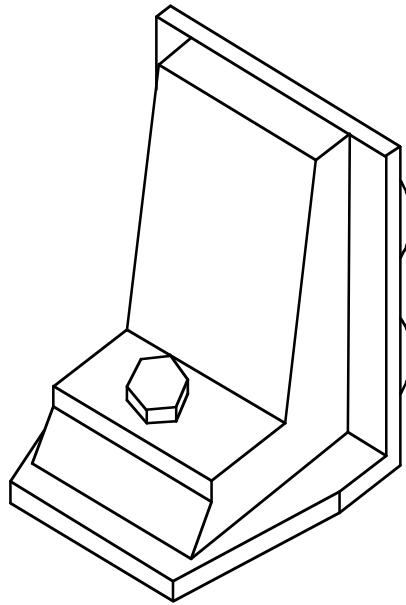

**MOUNTING BRACKET**

*Figure 1-1. M93 MVS Components (Sheet 1 of 2)*

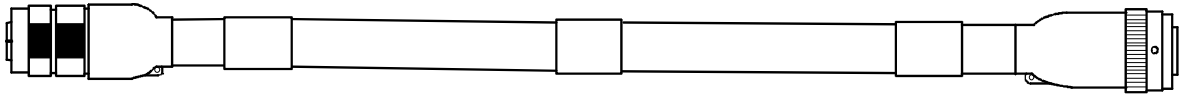

POWER AND DATA CABLE (0.75-METER)

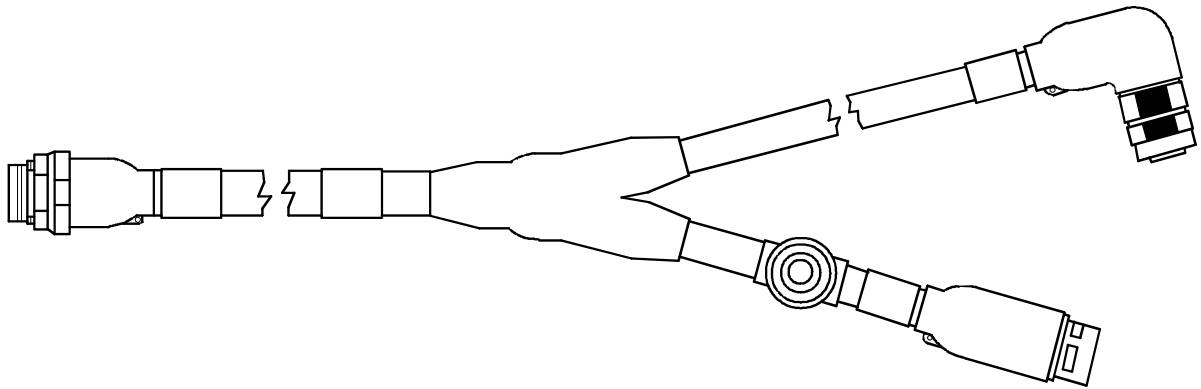

POWER AND DATA CABLE (5-METER)

Figure 1-1. M93 MVS Components (Sheet 2 of 2)



**1.5 SAFETY, CARE, AND HANDLING.**

**1.5.1 Electrostatic Discharge (ESD) Awareness.** It is essential to understand the nature of electrostatic discharge (ESD), what causes it, and the problems it can cause. This paragraph contains information on the areas of major concern.

**1.5.2 Typical Prime Charge Sources.** Means of generating electrostatic charges (voltage) and their relationship to relative humidity are shown in Table 1-2.

*Table 1-2. Means of Static Charge Generation*

Means of Static Generation	Electrostatic Voltages- 10-20 Percent Relative Humidity	Electrostatic Voltages- 65-90 Percent Relative Humidity
Walking across carpet	35,000	1,500
Walking on vinyl floor	12,000	250
Worker at workbench	6,000	100
Vinyl envelopes for work instructions	7,000	600
Common poly bag picked up from bench	20,000	1,200
Work chair padded with polyurethane foam	18,000	1,500

**1.5.3 Prime Charge Carriers.** Personnel are the prime charge carriers with the greatest potential of damaging ESD items. Activities such as walking, working at a table or bench, sliding on a chair, or simply combing one's hair can generate static charges of thousands of volts with high potential for damage to sensitive devices.

**1.5.4 Items to Avoid.** The following items will generate sufficient charges to damage sensitive items: all common plastics, spray cans, tape dispensers, heating guns, bubble packs, polystyrene cups, cigarette papers and wrappers, paint cans, stencil ink applicators, common poly bags and sheets, and plastic tape.

**1.5.5 Handling Unpackaged ESD Sensitive Items.** Never store or transport ESD sensitive components or assemblies outside of the protective packaging. The protective packaging should not be opened or removed until the item is to be installed in the next higher assembly. At this time, the technician should be grounded in an approved workstation. Avoid touching bare leads and contacts on sensitive material. Never use plastic solder suckers to remove soldered components from ESD sensitive assemblies. Use metallic or antistatic solder removal means.

**1.5.6 Packaging and Labeling ESD Sensitive Items/Assemblies.** After replacement of a sensitive circuit card assembly (CCA) or other subassembly into an instrument, the CCA that is to be returned for repair must be repackaged in ESD protective material to prevent further damage. Mom handling and transit. For field returns, antistatic ziplock bags are available for CCAs and other small assemblies. The container with the ESD sensitive material warning label should also be used for returning defective material to ensure proper handling during shipment.

**1.5.7 Types of ESD Sensitive Devices.** ESD sensitive devices and information pertaining to susceptibility are listed in Table 1-3.

*Table 1-3. Device Type an Range of ESD Susceptibility (Volts)*

Device Type	Range of Susceptibility (Volts)
VMOS	30 to 1800
MOSFET	100 to 200
GaAsFET	100 to 300
EPROM	100
JFET	140 to 7000
SAW	150 to 500
OP AMP	190 to 2500
CMOS	250 to 3000
Schottky Diodes	300 to 2500
Film Resistors	300 to 3000
Bipolar Transistors	380 to 7000
ECL (PC Board Level)	500 to 1500
SCR	680 to 1000
Schottky TTL	1000 to 2500

**1.5.8 Army Adopted Configuration.** In general, a protective workstation must occupy a 10-foot (3-meter) square area and be cordoned off with yellow lines or other means of segregation. The area should be posted with signs identifying it as a static-free work area. This protective station may be used for packaging or by maintenance personnel for repairing sensitive devices, but not when applying power to the instrument for testing.

**1.5.9 Precautions within 20-foot (6-meter) Distance.** For purposes of initially established work-sites, the major controlled area shall be considered as that area within a 20-foot (6-meter) radius of the bench(es). Within this controlled area, the following should be excluded:

- a. Materials handling trucks, carts, and equipment.
- b. Conveyor drive mechanisms and moving belts.
- c. Sandblast and air-cleaning equipment.
- d. Paint spray booths and ventilating equipment.
- e. Storage of bulk common plastic materials such as large rolls of cushion wrapping material, loose fills, slab cushioning, or fastpacks.

**1.5.10 Precautions within 50-foot (15-meter) Distance.** A special hazard exists in areas where stretch and shrink wrapping operations are performed. This is also true where skin packaging, foam-in-place, and plastic bagging are conducted. These types of functions must be kept at least 50 feet (15 meters) away from static-protected worksites.

**1.5.11 Chairs.** Chairs are generally not recommended within the protected areas. If used, due to physical impairment of personnel, they must be of conductive construction, making good electrical contact with the grounded floor material, and must have conductive seat covers.

## **1.6 CORROSION PREVENTION AND CONTROL.**

While corrosion is typically associated with rusting of metals, it can also include deterioration of other materials, such as rubber and plastic. Unusual cracking, softening, swelling, or breaking of the materials may be a corrosion problem. If a corrosion problem is identified, it should be reported using Standard Form 368, Product Quality Deficiency Report. Use of keywords such as "corrosion", "rust", "deterioration", or "cracking" will ensure that the information is identified as a CPC problem. Army users submit Product Quality Deficiency Report (SF 368) to:

Commander, U.S. Army Armament Research, Development and Engineering Center  
ATTN: AMSTA-AR-WAW-C/Customer Feedback Center  
Rock Island, IL 61299-7300  
FAX: DSN 793-6653, Commercial (309) 782-6653  
E-mail: [qawqdrs@ria.army.mil](mailto:qawqdrs@ria.army.mil)

## **1.7 DESTRUCTION OF ARMY MATERIEL TO PREVENT ENEMY USE.**

Only the commanding officer can give the order to destroy materiel to prevent enemy use. Refer to TM 750-244-6.

## **1.8 DECONTAMINATION OF COMPONENTS.**

The components of the M93 MVS have been coated with a chemical agent resistant coating (CARC) to aid you in the decontamination (deliberate removal of a chemical agent hazard) by one or a combination of chemical treatments, evaporating with hot air absorbents, or other methods. There are two levels of decontamination.

- a. Partial - just enough contamination is removed or neutralized to allow soldiers to sustain operation.
- b. Complete - When contamination is reduced to a level that permits soldiers to operate for extended periods without wearing protective clothing; e.g., mask, gloves.

The application of CARC has improved the efficiency by which the decontamination process can be accomplished. Therefore, it is important that you maintain this coating through the proper application of paint, which contains CARC properties, whenever you apply paint. For additional information and instructions pertaining to nuclear, biological, and chemical (NBC) decontamination, refer to FM 3-5 (NBC Decontamination). Complete instructions regarding the application of CARC are provided in TM 43-0139 (Painting Instructions for Army Materiel).

## **1.9 REPORTING EQUIPMENT IMPROVEMENT RECOMMENDATIONS (EIR).**

If your M93 MVS needs improvement, let us know. Send us an EIR. You, the user are the only one who can tell us what you don't like about your equipment. Let us know why you don't like the design or performance. Put it on an SF 368 (Product Quality Deficiency Report) and mail it to:

Commander, U.S. Army Armament Research, Development and Engineering Center  
ATTN: AMSTA-AR-WEP/Customer Feedback Center  
Rock Island, IL 61299-7300  
FAX: DSN 793-6339, Commercial (309) 782-6339 or (309) 782-3065  
E-mail: [menkej@ria-army.mil](mailto:menkej@ria-army.mil)

**SECTION II. EQUIPMENT DESCRIPTION**

**Section Contents**

<b>Subject</b>	<b>Page</b>
Equipment Features.....	1-8
Equipment Performance .....	1-8
Physical Characteristics.....	1-9
Power Requirements .....	1-9
Environmental Information .....	1-10
Principles of Operation.....	1-10
Muzzle Velocity Measurement and Calculation .....	1-10
System Interconnection .....	1-11

---

**1.10 EQUIPMENT FEATURES.**

MV Measurement:	Accurately measures the muzzle velocity provided the proper minimum/maximum expected muzzle velocity range is transmitted by the AFCS.
System interface	Communicates with the AFCS (and thereby with the operator) using a pre-defined protocol across a MIL-STD-1553B communication interface.
Self-Test	Extensive built-in tests (BIT) which run upon startup to detect system malfunctions.

**1.11 EQUIPMENT PERFORMANCE.**

Velocity Measuring Range .....	150 - 1500 meters/second
Caliber Range: .....	40 mm and up
Projectile Types: .....	Conventional, base-bleed, sabot-discarding, rocket-assisted, tracer ammunition, deep cavity
Accuracy: .....	Within 0.05% of the true muzzle velocity
Precision .....	0.1 m/s
Firing Rate: .....	16 rounds per minute maximum
Firing Detection: .....	Automatic triggering
Measuring (Transmitting) Duration: .....	500 msec
MV Calculation Duration: .....	3.25 sec maximum

Flank Firing: ..... No mutual interferences  
 ..... when two systems operate  
 ..... on parallel guns, 30 meters

**Transceiver**

Transmitted Frequency: ..... 10,525 ± 1 MHz  
 Transmitted Power: ..... 120 to 240 mW

Antenna

Type: ..... Microstrip  
 Gain: ..... 22 db minimum  
 Side Lobe Level: ..... -12 db minimum below main  
 ..... lobe

**Beamwidth:** ..... E-PLANE: 15° ± 2°  
 ..... H-PLANE: 7° ± 2°

Cross Polarization: ..... -24 db maximum  
 Squint Angle: ..... E-PLANE: 0 ± 1°  
 ..... H-PLANE: 7 ± 1°

**1.12 PHYSICAL CHARACTERISTICS.**

Transceiver

Size (H x W x D): ..... 12 x 8.4 x 3.8 inch  
 ..... (304 x 214 x 96 mm)  
 Weight: ..... 14.5 lb (6.6 Kg)

**Mounting Bracket**

Size (H x W x D): ..... 8.3 x 7.4 x 6.6 inch  
 ..... (210 x 187 x 167 mm)  
 Weight: ..... 7.9 lb (3.6 Kg)

**1.13 POWER REQUIREMENTS.**

Operating Voltage: ..... 18-30 VDC  
 Power Consumption: ..... 15 W in standby mode; 24 W  
 ..... in measure mode.

**1.14 ENVIRONMENTAL INFORMATION.**

The M93 MVS is designed to withstand adverse conditions, which may be present during storage and operation. The M93 MVS will function properly without degradation under the following conditions:

- a. Operation temperatures from -50° F to +125° F
- b. Storage temperatures from -50° F to +150° F
- c. 0% to 95% relative humidity including condensation
- d. Shocks and vibrations present during gun fire and transport

## ARMY TM 9-1290-365-24&P

- e. High altitude during air transport
- f. Rain and wind
- g. Sand and dust
- h. Solar radiation (direct sunlight)
- i. Salt fog
- j. Environments leading to growth of fungus

### 1.15 PRINCIPLES OF OPERATION.

The M93 MVS Transceiver is a compact Doppler transmitter-receiver that generates a Doppler signal related to the velocity of projectiles fired from the gun on which the transceiver is mounted. The gun firing is detected by an automatic triggering device which starts the measuring process (transmits RF-energy). The transceiver transmits RF energy only when the system is in measure mode. The system transmits a low-power signal in the X band range. The echo frequency returned from the projectile is shifted in frequency relative to projectile velocity. This frequency undergoes mixing with the transmitted frequency in order to achieve a Doppler frequency:

$$F_d = F_t - F_r = \frac{2F_t}{C} V$$

Where:

- $F_r$  - frequency received by antenna
- $F_t$  - frequency transmitted by antenna
- $C$  - speed of light
- $V$  - projectile velocity relative to gun
- $F_d$  - Doppler frequency

Projectile velocities between 150-1500 m/sec will generate a Doppler frequency between 10-100 kHz. This frequency is sampled and processed in order to derive the projectile muzzle velocity. Using the Doppler effect and fast fourier transform algorithm (FFTA), the projectile instantaneous velocity is measured at up to 64 predefined in-flight intervals. This data is sorted by statistical methods to calculate the best fit regression curve and used to extrapolate the projectile velocity upon exiting the gun tube (Muzzle Velocity - MV).

### 1.16 MUZZLE VELOCITY MEASUREMENT AND CALCULATION.

The MVP starts the Doppler sampling process when triggered by a signal received from the transceiver. This instant is referred as  $t = 0$ . The Doppler signal is then processed to obtain the projectile's velocity at several predefined instances. The requested MV is obviously  $V(t = 0)$ . This value can be calculated by finding the best-fit linear regression curve of the form:

$$V(t) = at + b$$

Where:

- $t$  - Time in seconds
- $V(t)$  - Instantaneous velocity
- $a, b$  - Linear regression constants.

The MVP employs a highly advanced signal processing algorithm implemented on a modern digital signal processor (DSP). This DSP is extremely fast and, as such, is capable of performing computational intensive and highly sophisticated computing algorithms, which are based on the FFTA.

#### **1.17 SYSTEM INTERCONNECTION.**

The system interconnection is provided in Figure 1-2. The transceiver is mounted on the gun and connected to the Paladin. The 0.75-meter power and data cable is connected to J1 on the transceiver and to the adapter connector of the 5-meter power and data cable.

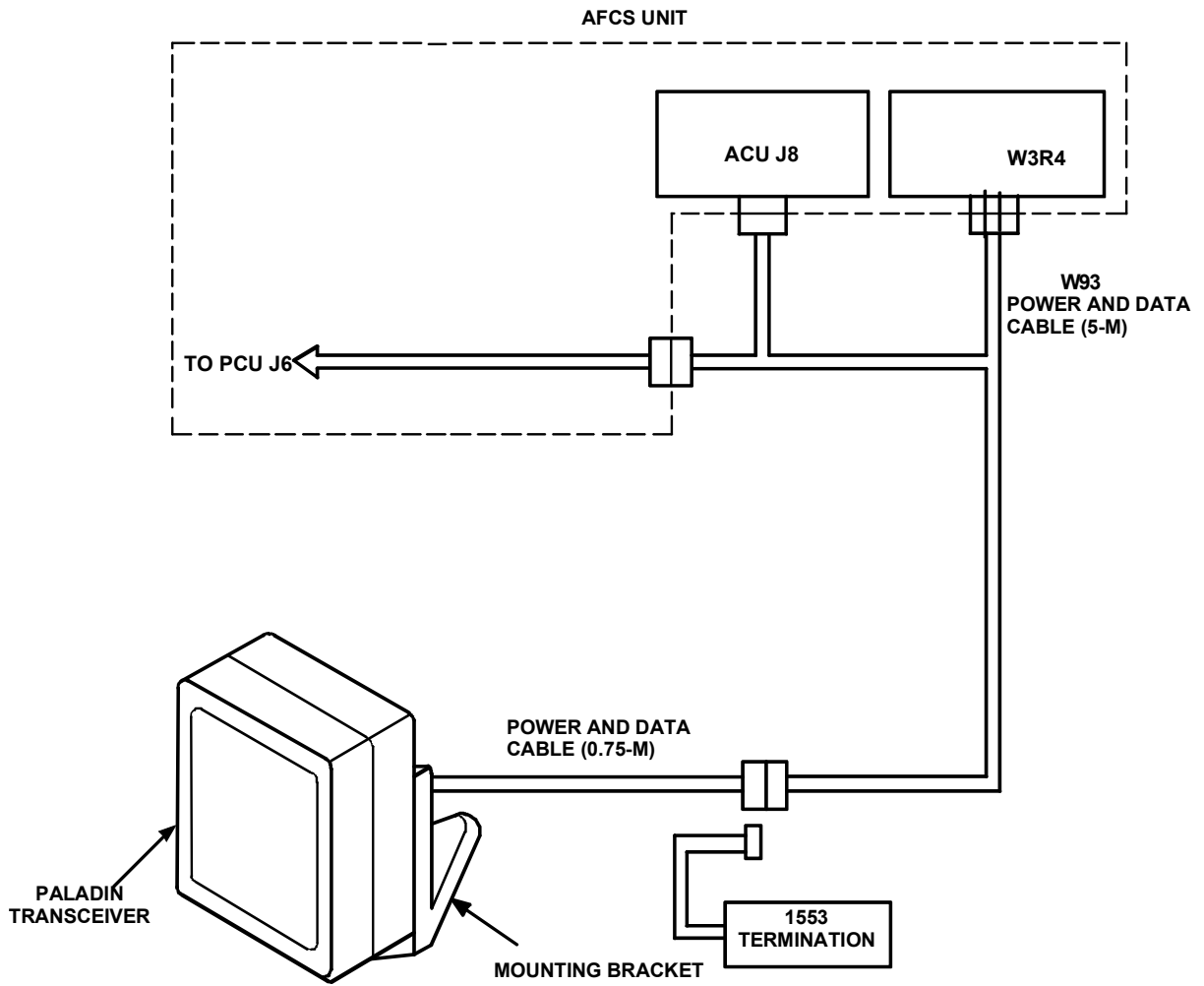

Figure 1-2. M93 MVS Interconnection



SECTION III. COMPONENT DESCRIPTION

SECTION CONTENTS

<b>Subject</b>	<b>Page</b>
System Components.....	1-13
Transceiver Assembly.....	1-13
Mounting Bracket.....	1-13
Power and Data Cables.....	1-13
Transceiver Assembly.....	1-14
General Description.....	1-14
RF Section.....	1-15
Doppler Amplifier.....	1-15
Power Supply Module.....	1-16
Muzzle Velocity Processor (MVP).....	1-17
Mechanical Construction.....	1-20
RF Section.....	1-20
Back Cover Assembly.....	1-20
Mounting Bracket.....	1-23
Power and Data Cables.....	1-24
1553 Termination.....	1-25

**1.18 SYSTEM COMPONENTS.**

The M93 MVS is a muzzle velocity measurement system, which operates on the Doppler principle and is designed to be operated under field conditions. The system is based on an X band transceiver and a muzzle velocity processor (MVP). When not in use, the Paladin MVS can remain installed on the Paladin gun or housed and transported in a transit case. Table 1-1 provides M93 MVS system components and part numbers.

**1.18.1 Transceiver Assembly.** The transceiver assembly is an X band transmitter and receiver, which provides the Paladin AFCS with the velocity of the projectile via the MIL-STD-15538 data bus. The transceiver assembly is mounted on the non-recoiling part of the gun using the mounting bracket.

**1.18.2 Mounting Bracket.** The bracket is used to mount the transceiver assembly on the gun. It contains shock absorbers and is firmly mounted on the gun.

**1.18.3 Power and Data Cables.** The M93 MVS has two cables. The 0.75-meter power and data cable connects the transceiver to the 5-meter power and data cable, which is installed inside the gun cab. The 5-meter cable provides the transceiver with the power through connection to the Paladin PCU and communication bus through connection to the Paladin CP

### 1.19 TRANSCEIVER ASSEMBLY

**1.19.1 General Description.** For the following description, refer to Figure 1-3. The transceiver is divided into four main subassemblies:

- a. RF section
- b. Doppler amplifier
- c. Power supply
- d. Muzzle velocity processor (MVP)

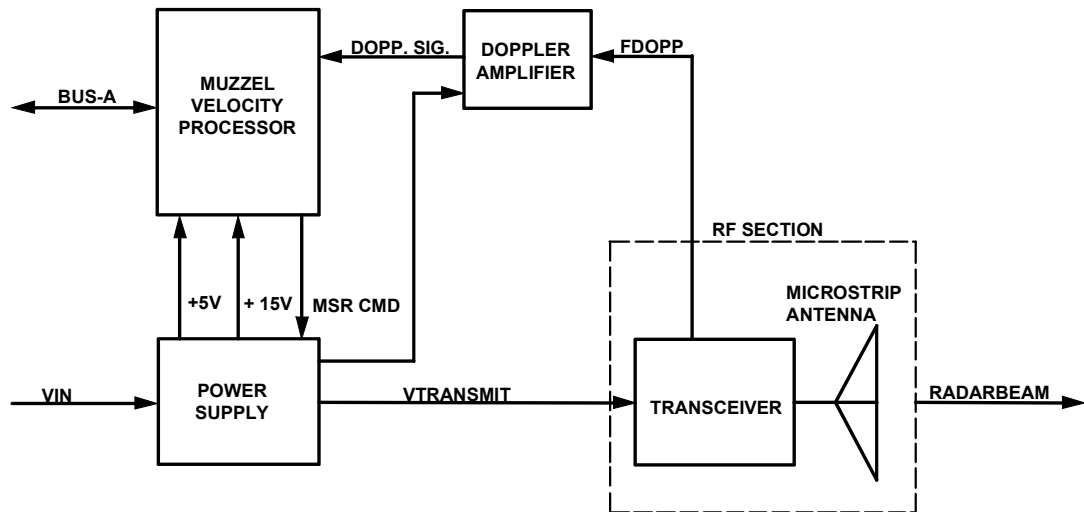
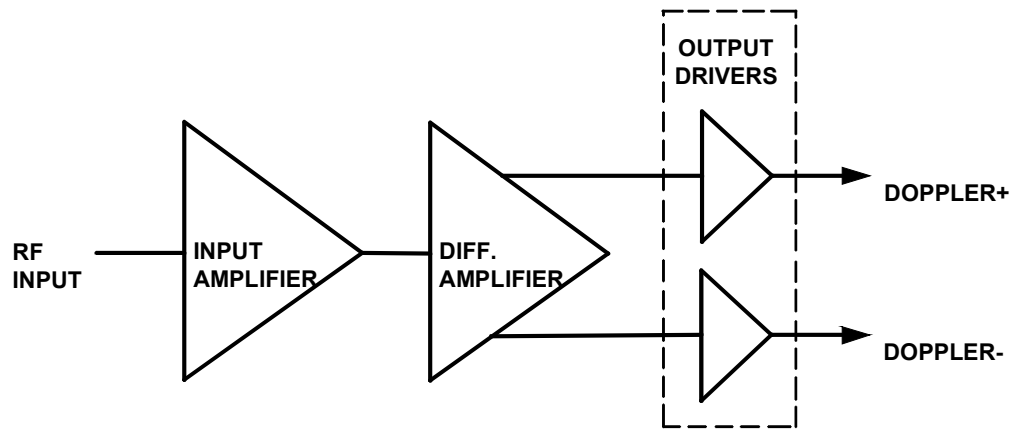

Figure 1-3. Transceiver Assembly Simplified Block Diagram

**1.19.2 RF Section.** The RF section consists of an antenna and a transceiver. The transceiver consists of an extremely stable oscillator, circulator, and mixer. The RF system transmits a low-power, continuous microwave (X band) signal and receives Doppler-shifted echoes. The detected frequency difference between the transmitted and received frequencies is proportional to the projectile velocity.

**1.19.3 Doppler Amplifier.** For the following description, refer to Figure 1-4. The Doppler amplifier consists of an amplifier with a bandwidth of 3-140 kHz. The input of the Doppler amplifier is the RF system output, which is filtered, amplified, shaped, and transmitted through a differential line driver to the muzzle velocity processor.



*Figure 1-4. Doppler Amplifier Module Simplified Block Diagram*

**1.19.4 Power Supply Module.** For the following description, refer to Figure 1-5. The power supply generates +18, +5, +15 and -15 , and predetermined 9-11 VDC operating voltages for the transceiver internal circuitry. The topology of the power supply is a current mode, forward converter with input and output coupling. Switching frequency is 400 kHz. The RF signal transmission is controlled by the MVP through the. MEASURE CMD (on/off) signal.

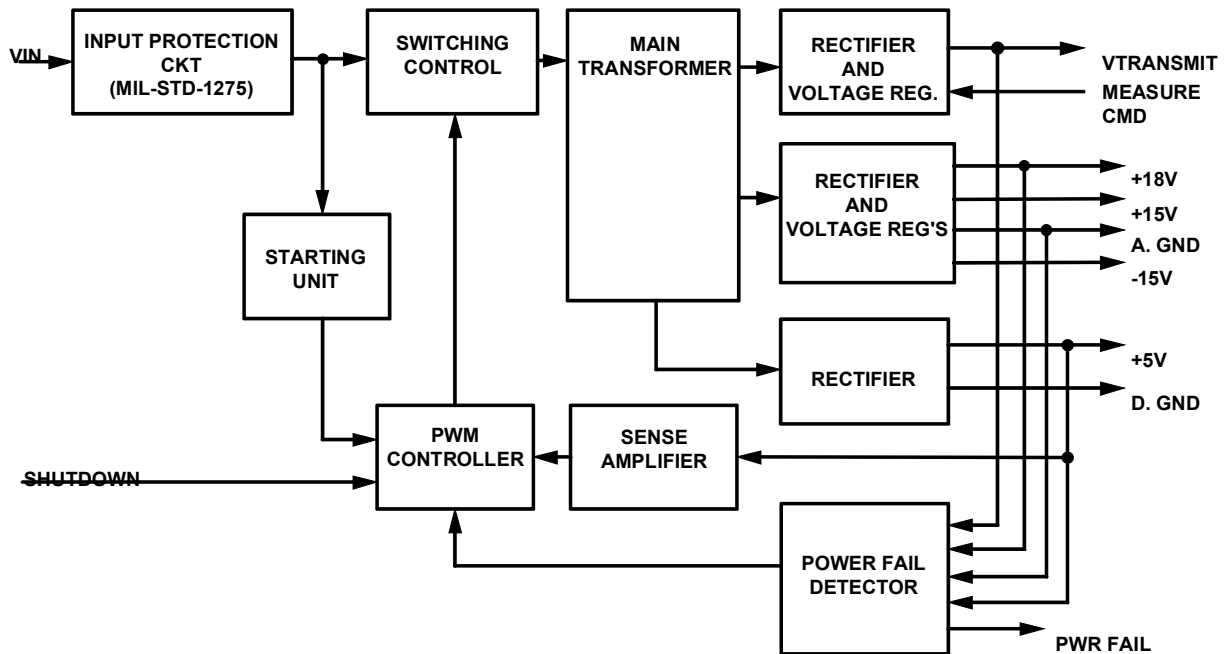

Figure 1-5. Power Supply Module Simplified Block Diagram

## **ARMY TM 9-1290-365-24&P**

**1.19.5 Muzzle Velocity Processor (MVP).** The MVP is based on the ADSP-2100 Digital Signal Processor. The MVP circuits and parameters are as follows:

- a. 32 K x 24 fast EPROM
- b. 32 K x 16 fast RAM
- c. Clock and timing generation circuits
- d. Doppler signal input circuits
- e. Measure control circuits
- f. Automatic fire detection circuit
- g. MIL-STD-1553 interface

**1.19.5.1 ADSP-2100 DIGITAL SIGNAL PROCESSOR (DSP).** For the following description, refer to the block diagram in figure 1-6. The circuits and parameters are as follows:

- a. 32-MHz clock
- b. 24-bit program bus
- c. 16-bit data bus
- d. Multiply and accumulate instructions
- e. Instructions performed in 125 nsec

**1.19.5.2 PROGRAM MEMORY.** The program memory consists of 32 K x 24-bit words of high-speed EPROM. The EPROM components are on-board programmable.

**1.19.5.3 WORK MEMORY.** The work memory consists of 32 K x 16-bit, high-speed RAM and serves as the sampling and processing work space.

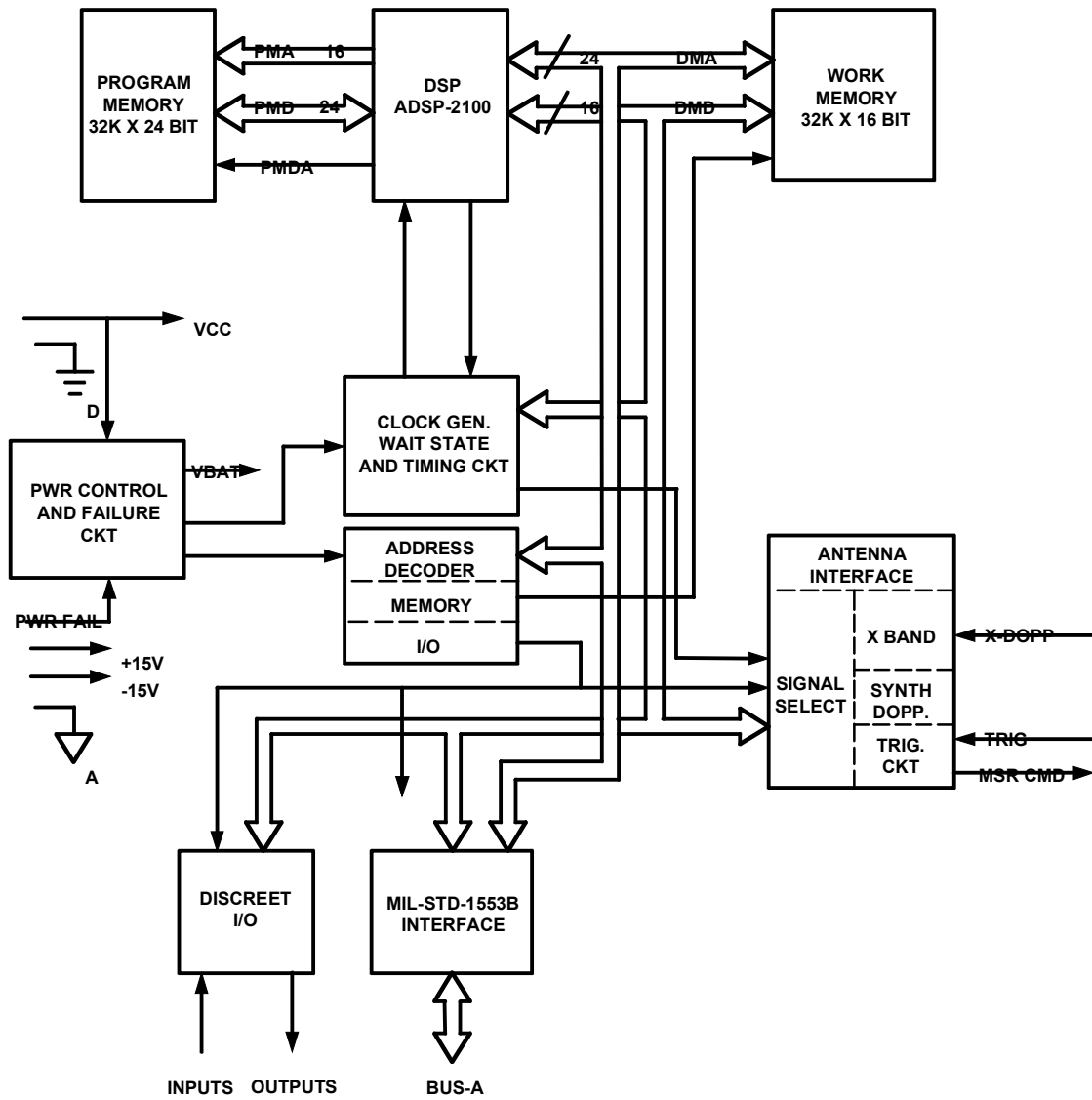

Figure 1-6. MVP Simplified Block Diagram

1.19.5.4 TRANSCEIVER INTERFACE. The transceiver interface consists of several circuits, which enable an interface between the module and the transceiver. These circuits consist of:

- a. An X band interface which amplifies and reshapes the Doppler signal received from the X band transceiver.
- b. A precise synthetic Doppler frequency generated for self test purposes.
- c. A trigger circuit for defining the instant of firing and activating the Transceiver.
- d. A signal select circuit which transfers the required inputs for sampling and processing.

1.19.5.5 CLOCK GENERATOR, WAIT STATE, AND TIMING CIRCUITS. These circuits provide all the necessary system clock, wait states, and other timing such as sampling rate for Doppler signal and baud rate for serial communications.'

1.19.5.6 POWER CONTROL AND FAILURE CIRCUIT. This circuit provides the required reset and power failure signals. The power failure signal is used to protect the data base memory from being mistakenly overwritten during power on/off or failure. This circuit provides the system the ability to operate properly upon input power disturbances (power decrease under 18 VDC) caused by start up of other equipment. This is provided by a capacitor, which supplies the power to the work memory (RAM) for the period of the power disturbance. The system current mode of operation is stored in that memory. The processor checks that mode and continues operation from the condition it was before the power disturbance occurred. If the power disturbance lasts longer than 3.5 seconds, the M93 MVS resumes operation as if initially powered-up.

1.19.5.7 DISCRETE I/O. Several discrete inputs/outputs are provided for general use.

1.19.5.8 ADDRESS DECODER. The address decoder decodes the various MVP module component addresses when a read/write operation to them is required.

1.19.5.9 MIL-STD-1553B INTERFACE. The MIL-STD-1553B Interface is implemented using a chip set which is based on the Aeroflex C12577-10-QM-P119 chip and associated circuitry. The chip is capable of functioning as a remote terminal (RT) and contains dual low-power transceivers and encoder/decoders, complete BC/RT protocol logic, 4 K x 16 shared static RAM and a direct buffered interface to the host processor bus. The CT2577-10-QM-P119 in the RT mode is able to be addressed within the address range 00001 through 11110 by using the RTADO - RTAD4 and RTADP lines.

1.19.5.10 AUTOMATIC FIRE DETECTION CIRCUIT. The MVP contains an acceleration switch, which detects the instant of gun firing and provides the command to start the measuring process (to start RF transmission and signal sampling).

## **1.20 MECHANICAL CONSTRUCTION.**

The transceiver unit consists of the following assemblies:

- a. RF section assembly.
- b. Back cover assembly

**1.1.20.1 RF Section.** For the following description, refer to Figure 1-7. The RF section assembly accommodates all RF components (microstrip antenna, transceiver and RF cable which connects between them), the Doppler amplifier, and the power supply. The Doppler amplifier and the power supply are covered with special covers for EMI protection. A silicone rubber gasket seal is positioned between the RF section and the back cover.

**1.1.20.2 Back Cover Assembly.** For the following description, refer to Figure 1-8. The back cover assembly accommodates the interface connector, the EMI filter module, and the MVP. The connector is protected with a dust cap. Six captive screws fasten the back cover to the RF section. The back cover is recessed at the connector area in a way that provides a handle for easy carrying and contains four mounting holes for mechanical mounting on the mounting bracket.



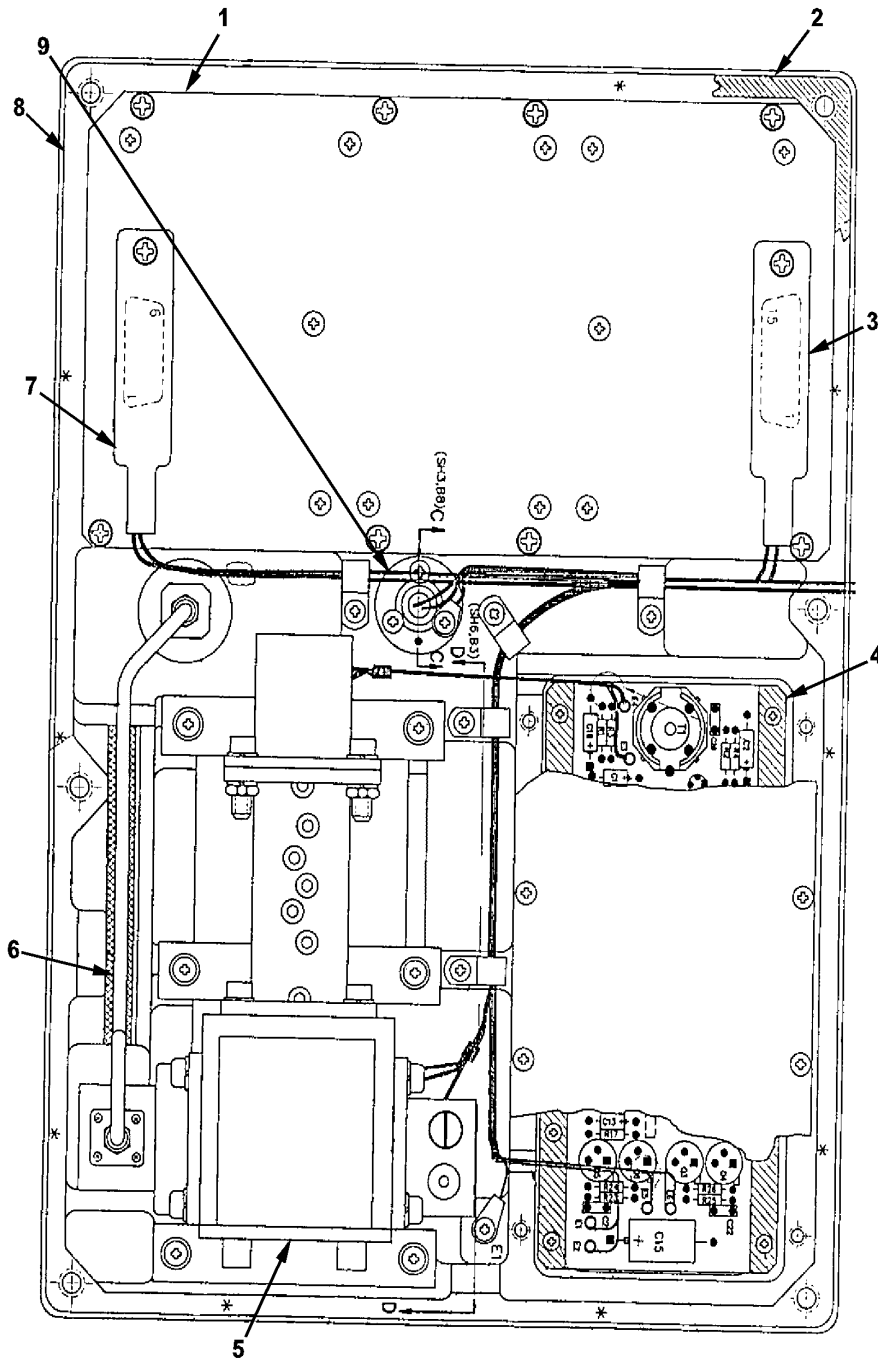

- LEGEND
1. POWER SUPPLY MODULE
  2. GASKET
  3. CONNECTOR P2
  4. DOPPLER AMPLIFIER CCA
  5. TRANSCEIVER
  6. RF CABLE
  7. CONNECTOR P1
  8. MICROSTRIP ANTENNA
  9. INTEGRATED DOPPLER SIMULATOR

Figure 1-7. Transceiver RF Section (Part of Transceiver Assy, P/N 13002074)

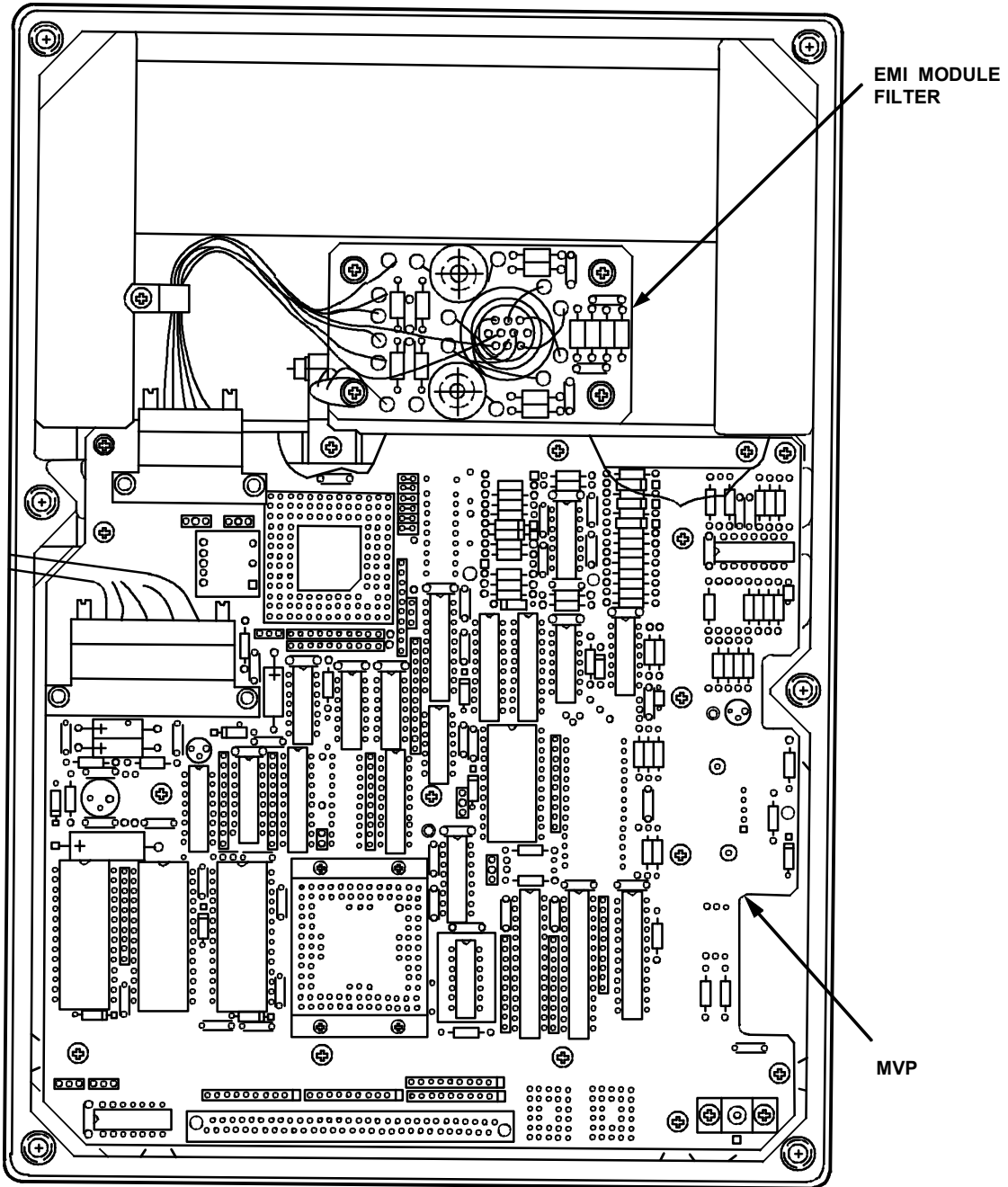
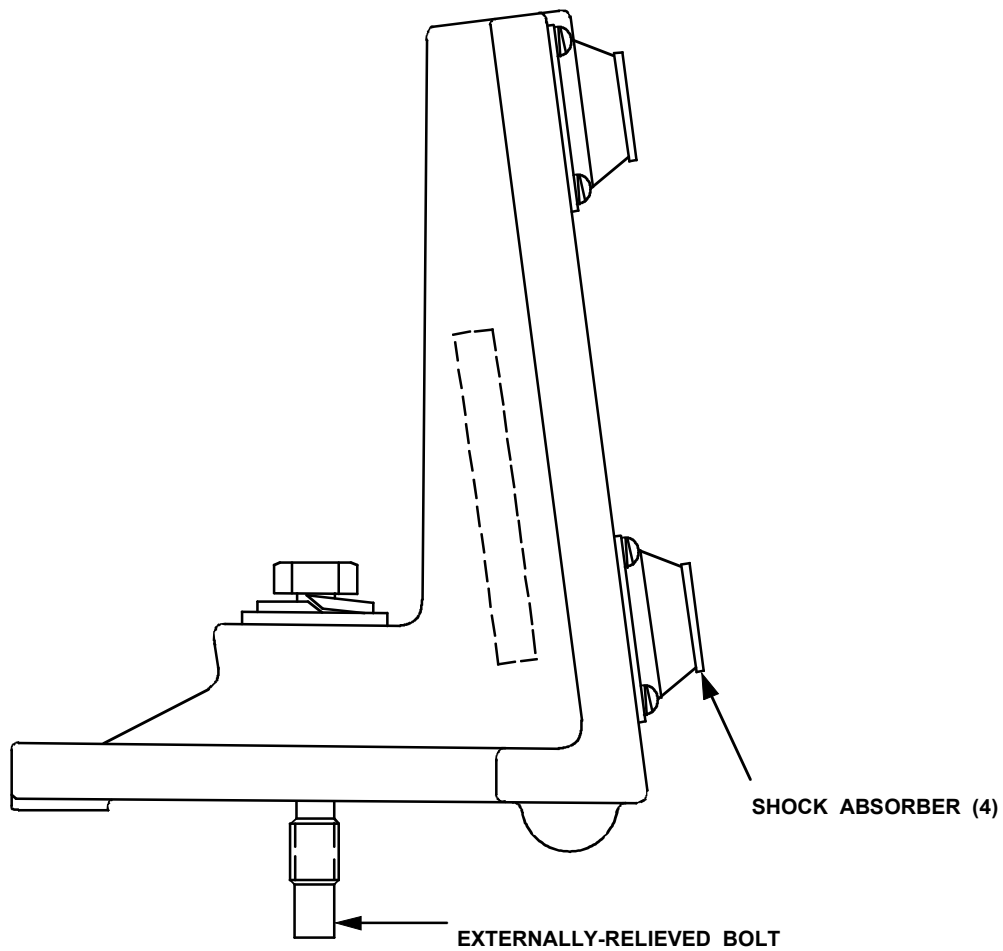

Figure 1-8. Transceiver Back Cover Assembly (Part of Transceiver Assy, P/N 13002074)

**1.21 MOUNTING BRACKET**

For the following description, refer to Figure 1-9. The mounting bracket is used for mounting the transceiver onto the gun. The bracket is fabricated from aluminum casting and is painted in the same color as the transceiver. The bracket contains four shock absorbers to which the transceiver is mounted and it is firmly mounted to the gun by an externally-relieved bolt.



*Figure 1-9. Mounting Bracket Assy, P/N 12979003*

**1.22 POWER AND DATA CABLES.**

For the following description, refer to Figure 1-10. The M93 MVS cables are manufactured using military standard wire, which is covered from the outer side by a high-performance jacket. The connectors are protected by bonded boots, which are waterproof and provide EMI shielding protection. The connector plugs are covered by protective dust caps. Each connector is marked with its designation number and destination definition.

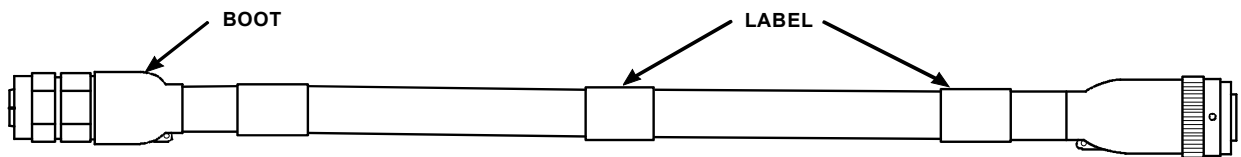

**POWER AND DATA CABLE (0.75-METER), P/N 12979004**

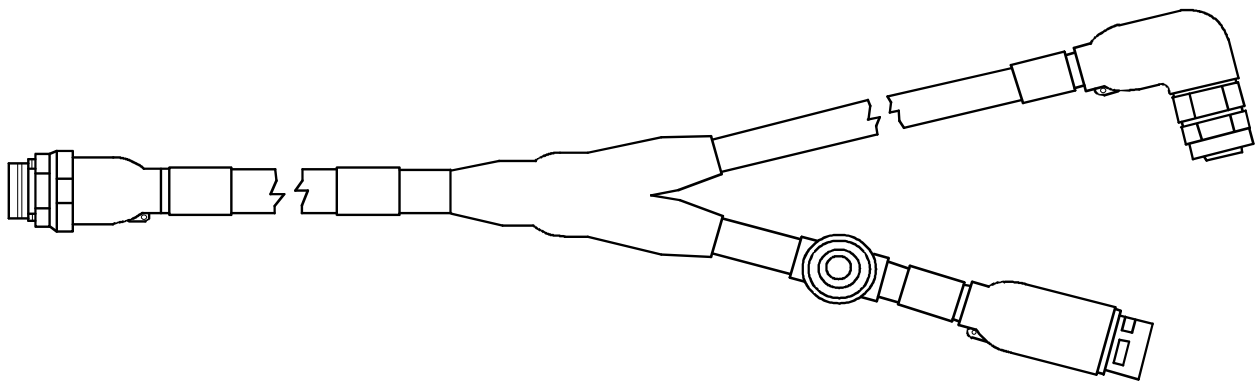

**POWER AND DATA CABLE (5-METER), P/N 12991852**

*Figure 1-10. Power and Data Cables*

**1.23 1553 TERMINATION.**

For the following description, refer to Figure 1-11. When the M93 MVS is not installed, a special termination is installed on the AFCS line, thus simulating a match line impedance.

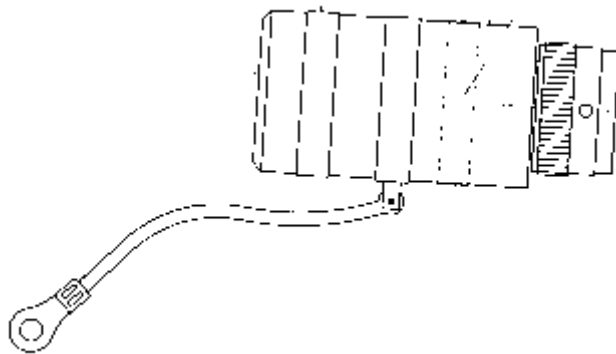

*Figure 1-11. 1553 Termination, P/N 12979006*



**CHAPTER 2**

**OPERATING INSTRUCTIONS**

**CHAPTER CONTENTS**

<b>Subject</b>	<b>Page</b>
General .....	2-1
MV Min/Max Range .....	2-1

**2.1. GENERAL.**

The M93 MVS operates as a slave to the M109A6 Paladin Automatic Fire Control System (AFCS), and as such exchanges data across the MIL-STD-1553B Data Bus. The operator indirectly controls the MVS by issuing commands to the AFCS. The purpose of this section is to explain the various MVS associated activities available when running the AFCS software. In what follows, reference is made to the Version 11 Software Upgrade (TM 9-2350-314-10), henceforth referred to as the Paladin TM. See the Paladin TM, Para 2-22 for M93 MVS operating procedures, and to Appendix K for troubleshooting procedures.

**2.2. MV MIN/MAX RANGE**

The MVS must receive a minimum MV/maximum MV range in order to measure properly. If actual MVS to be measured do not fall in this range, the MVS will not be able to measure the MV properly. The AFCS transmits the MV min/max range to the MVS based on the projectile/propellant/charge combination, which the operator selects when entering the ammunition data. If the actual ammunition fired does not match the data entered into the AFCS, the MVS most likely will return measurement errors. Refer to Paladin TM for operating instructions of proper MV setting.





---

**CHAPTER 3**  
**MAINTENANCE INSTRUCTIONS**

---

**CHAPTER CONTENTS**

		<b>Page</b>	
Section I	General Instructions .....	3-3	
Section II	Power and Data Cable (0.75-Meter), P/N 12979004 .....	3-7	
Section III	Power and Data Cable (5-Meter), P/N 12991852 .....	3-13	■
Section IV	1553 Termination, P/N 12979006 .....	3-25	
Section V	Bracket Assembly, P/N 12979003 .....	3-29	
Section VI	Transceiver Assembly, P/N 13002074 .....	3-33	■



**SECTION I. GENERAL INSTRUCTIONS**

**Section Contents**

<b>Subject</b>	<b>Page</b>
General.....	3-3
Maintenance Scheduling .....	3-3
Materials Required .....	3-4
Cleaning .....	3-4
External Inspection.....	3-4
Refinish of Painted Surfaces.....	3-5
Replacement of Identification Plates .....	3-5
Cable Testing .....	3-5
Troubleshooting.....	3-5

---

**3.1. GENERAL.**

This chapter provides maintenance instructions for all M93 MVS components. Refer to Appendix D for all depot-level maintenance instructions on components that are not listed in this chapter.

**3.1.1 Maintenance Scheduling.** Table 3-1 provides the maintenance schedule for the M93 MVS and refers to the applicable paragraph, which describes the check.

*Table 3-1. Maintenance Schedule*

<b>Maintenance Level</b>	<b>Maintenance Action</b>	<b>Paragraph</b>	<b>Frequency</b>
Operator	-Cleaning -External Inspection -Self-Test	3.1.4 3.1.5	Every use Every use Every use
Organizational	a. R&R of Transceiver Assy, Power and Data Cables, and 1553 Termination. b. Repair of Mounting Bracket Assy.	3.2, 3.3, 3.4, 3.5, 3.6  3.5	As required  As required
Direct/General Support	a. Repair of Power and Data Cables b. Repair of 1553 Termination.	3.2 and 3.3 3.4	As required
Depot (Contractor)	-Repair of repairable components -Transceiver Performance	Appendix D Appendix D	As required

**3.1.2 Materials Required.** Repair materials and other consumable item required for general maintenance of the MVS are listed in Table 3-2.

*Table 3-2. Materials Required*

Nomenclature	Type/Part No.	Appendix F Item No.
Lint-Free Cloth	8722-0088	7
Alcohol	TT-I-735A	4
Paint	MIL-C-46168 Color 383 IAW FED-STD-595, CARC	21
Methyl Ethyl Ketone (MEK)	ASTM-D-740	14

Equivalent substitutes may be used for above items.

**3.1.3 Cleaning.**



**WARNING**

Use solvent in a well-ventilated area. Avoid breathing vapors. Keep away from flame.

**NOTE**

Normally, the M93 MVS will not require cleaning of any internal parts because it is sealed against dirt and moisture.

- a. Clean M93 MVS units with a clean, lint-free cloth moistened with alcohol. Cleaning materials and compounds are listed in Table 3-2.
- b. Clean cable surfaces with a clean, lint-free cloth moistened with alcohol.
- c. Remove adhesive and heatsink compounds from parts using MEK.

**3.1.4 External Inspection.** If any discrepancies are discovered, refer to the applicable repair and replacement procedures provided in the appropriate sections of this chapter.

- a. Inspect all components for security of attachment.
- b. Inspect that Mounting Bracket is properly secured to gun. Check for missing bolts or physical damage.
- c. Inspect Transceiver Radome for physical damage. Clean if necessary.
- d. Inspect all cables for nicks, cracks, and broken wires.
- e. Inspect that cables are not pinched or crimped.

### 3.1.5 Refinish of Painted Surfaces.

**WARNING**

CARC paint is a carcinogenic material and must be used carefully.

**CAUTION**

DO NOT PAINT TRANSCEIVER RADOME.

Repair Transceiver Assy painted surfaces in accordance with TM 43-0139 using forest green color CARC IAW FED-STD-595.

**3.1.6 Replacement of Identification Plates.** Replace damaged plates as follows:

- a. Remove plate by peeling.
- b. Be sure plate installation area is clean of old bonding residue. Refer to para. 3.1.3 for cleaning instructions.
- c. Remove protective covering from back of plate and firmly press plate into place.

**3.1.7 Cable Testing.** Cable assembly testing consists of performing continuity checks. Each cable shall be tested for compliance with its individual wiring diagram. Refer to appropriate sections in Chapter 3 for cable testing and repair procedures.

**3.1.8 Troubleshooting.** Troubleshooting of the M93 MVS is limited to the interface between the MVS and AFCS. Troubleshoot IAW Table 3-3.

**3.1.9 Shipping Instructions for items not repairable at field level:**

a. Fill out DA 2407 and/or DA 2404 to describe defects with item and where the items need to be returned to. If serialized, include serial number of unit.

b. Address for Shipping:

Borish Manufacturing Corp.  
4511 East Paris SE  
Grand Rapids, MI 49512  
DODAC: CMASD8  
RIC: CCA

c. Send one copy of DA Form 2404 and 2407 to the above address and one copy to the following address:

TACOM-RI  
ATTN: AMSTA-LC-CFTC  
Rock Island Arsenal  
Rock Island, IL 61299-7630

Table 3-3. MVS/AFCS Interface Troubleshooting

Problem	Corrective Action
MVS BIT failed	Replace Paladin MVS Transceiver
MVS did not return BIT status message	<ul style="list-style-type: none"> <li>a. Replace Paladin MVS Transceiver.</li> <li>b. Replace Power and Data Cable (0.75-m)</li> <li>c. Replace Power and Data Cable (5-m)</li> <li>d. Troubleshoot AFCS interface.</li> </ul>
No DCU MVS communications	<ul style="list-style-type: none"> <li>a. Replace Paladin MVS Transceiver.</li> <li>b. Replace Power and Data Cable (0.75-m)</li> <li>c. Replace Power and Data Cable (5-m)</li> <li>d. Troubleshoot AFCS interface.</li> </ul>
AFCS cannot calculate MVV because of measure errors	<ul style="list-style-type: none"> <li>a. Verify that required AFCS data entered is correct.</li> <li>b. check that MVS is securely mounted on the gun.</li> </ul>
BIT is OK. MVS does not measure	<ul style="list-style-type: none"> <li>a. Verify Transceiver is securely mounted on the gun.</li> <li>b. Replace Paladin MVS Transceiver.</li> <li>c. Replace Power and Data Cable (0.75-m)</li> <li>d. Replace Power and Data Cable (5-m)</li> <li>e. Troubleshoot AFCS interface.</li> </ul>
No MVV Acquired	<ul style="list-style-type: none"> <li>a. On initialization, did the operator set the MVV rounds to the minimum required for the FM (I.E. the minimum number of good rounds required for MVS calculations?)</li> <li>b. For the FM in question, does the AFCS have the same type of ammo combination and quantity as the BCS required for the FM?</li> <li>c. Are extended lots specified for the propellant to be used in the FM?</li> <li>d. Was the charge to be used specified in the BCS CFF message?</li> </ul>
MVS Verification Check (Dry Fire)	<ul style="list-style-type: none"> <li>a. Initiate a BCS six (6) round FM to the gun Specifying HEA/M4A2/PDA/CHARGE4/EXPVEL=334 M/S</li> <li>b. When the 'Fire When Ready' screen appears on the AFCS, use a rubber mallet to tap lightly on the side of MVS radar head.</li> <li>c. For each tap, the number of rounds should decrement once.</li> <li>d. If the AFCS does not decrement, turn the unit in with a DA 2404 and DA 2407 describing the fault.</li> </ul>

**SECTION II. POWER AND DATA CABLE (0.75-METER),**

**P/N 12979004**

**Section Contents**

<b>Subject</b>	<b>Page</b>
General.....	3-7
Test Equipment and Special Tools Required .....	3-7
Materials Required .....	3-8
General Repair Requirements .....	3-8
Inspection .....	3-9
Continuity Test .....	3-9
Removal .....	3-10
Installation .....	3-10

---

**3.2. POWER AND DATA CABLE (0.75-METER), P/N 12979004**

**3.2.1 General.** The following paragraphs provide repair procedures and maintenance information for the M93 MVS Power and Data Cable (0.75-Meter), P/N 12979004. Source, maintenance, and recoverability code is PAODD.

**3.2.2 Test Equipment and Special Tools Required.** Test equipment and special tool requirements are listed in Table 3-4. Unless otherwise specified, the test equipment and special tools listed below will be used for testing the Power and Data Cable (0.75-Meter). Each commercially available item of test equipment can be replaced by equipment equivalent to that listed.

*Table 3-4. Test Equipment and Special Tools Required*

<b>Nomenclature</b>	<b>Part/Spec. No.</b>	<b>Appendix C Figure 11 Item No.</b>
Belt Wrench	Bertsch Co. No.1, Model 31335	18
Crimping Tool	Daniels, Model M22520/1-01	7
Crimping Tool Die	Daniels, Model M22520/1-02	10
Digital Multimeter	Fluke, Model 77-2	5
Electronic Equipment Tool Kit	PPL863	11
Heat Gun	Master-Mite, Model 10008	4
Insertion/Extraction Tool	M81969/14-02	2

**3.2.3 Materials Required.** Repair materials and other consumable item requirements are listed in Table 3-5.

*Table 3-5. Materials Required*

Nomenclature	Part/Spec. No.	Appendix F Item No.
Adhesive	S1184	3
Adhesive	S1125	2
Label	43-143	10
Primer	747-55	17
Primer	MIL-S-22473, Grade AA	20

**3.2.4 General Repair Requirements.** Refer to Figure 3-1. Repair or replace cable connectors as follows:

**CAUTION**

Using excess force when cutting boot may cause damage to wiring inside boot.

**NOTE**

Before replacing a connector, ensure that the replacement connector matches exactly the connector to be replaced.

- a. Using sharp knife, carefully cut boot (3) from end to end.
- b. Pry boot (3) off of backshell (2) and cable (4).
- c. Using connector pliers (soft jaw), remove backshell (2) from connector body (1 ) and slide away from connector (1).
- d. Tag and label wires.
- e. Using pin extraction tool, remove damaged pin and wire from connector body. Remove serviceable pins and wires also to facilitate installation of new boot (3).
- f. Remove connector (1 ) from cable (4).
- g. Move backshell (2) away from end of cable (4).
- h. Cut wire as close as possible to end of damaged pin.
- i. Strip insulation from wire as required to ensure that wire will seat properly in pin.
- j. Using crimping tool and crimping tool die, crimp pin to wire.

**NOTE**

Failure to place heat shrink boot and backshell on cable at this point and in correct sequence will require later removal of connector from cable to facilitate installation of boot and backshell.

- k. Slide new boot (3) on cable (4).
- l. Using insertion tool, insert pins into connector body (1).



**NOTE**

Failure to perform continuity check at this point may require complete disassembly of connector to correct improperly terminated connector pins.

- m. Perform continuity test of cable in accordance with para. 3.2.5. If cable checks good, proceed to step n.
- n. Using small wire brush, clean sealing compound residue from threads of connector body (1) and backshell (2).
- o. Apply primer to threads of connector body (1) and backshell (2).
- p. Apply sealing compound to threads of connector body (1) and backshell (2).
- q. Screw backshell (2) on connector body (1) and torque to 3.7 in-lb (5 N.m).
- r. Apply S1184 adhesive to inside of boot (3) to bond with cable shield and backshell (2).
- s. Apply 51125 adhesive inside of boot (3) for bonding to cable jacket (4) and backshell (2).
- t. Place boot (3) on backshell (2).
- u. Using heat gun, apply heat uniformly to boot (3) until boot shrinks to form secure seal around backshell (2) and cable (4).

**3.2.5 Inspection.** Refer to Figure 3-1. Inspect Power and Data Cable (0.75-Meter) as follows:

- a. Inspect all parts for damage, wear, and deterioration.
- b. Inspect all wiring for bent or broken leads; cracked, frayed, deteriorated, worn, overheated, or burned insulation, and security of attachment.
- c. Inspect connectors (1,5) for broken, bent, recessed, loose, damaged, or missing pins.

**3.2.6 Continuity Test.** Refer to Table 3-6 and Figures 3-2 and 3-3. Check wiring continuity as follows:

- a. Set DMM to RESISTANCE mode.
- b. Set DMM to OHMS X 1 mode.
- c. Zero DMM to eliminate internal resistance of DMM and resistance of test leads.
- d. Measure continuity between connector plugs P1 and P2 in accordance with Table 3-6. Resistance should not exceed 0.5 ohm.
- e. Set DMM to OHMS X 10K mode.
- f. Measure resistance between each connector pin and adjacent pins. Resistance should be infinite.
- g. If incorrect readings are noted in step d. or f., repair or replace wire or connector.

Table 3-6. Power and Data Cable (0.75-Meter), P/N 12979004, Wiring Table

From Connector - Pin	To Connector - Pin
P1 - A	P2 - A
P1 - B	P2 - B
P1 - E	F2 - E
P1 - F	P2 - F
P1 - J	P1 - C
P2 - J	P2 - C
P1 - C	P2 - C

**3.2.7 Removal.**

- a. Disconnect Power and Data Cable, P/N 12979004 from Transceiver Assy and Power and Data Cable (5-m) on the other end by loosening connectors P1, P2.
- b. Remove cable from the gun.

**3.2.8 Installation.** Install Power and Data Cable to Transceiver Assy and Power and Data Cable (5-m) on the other end.

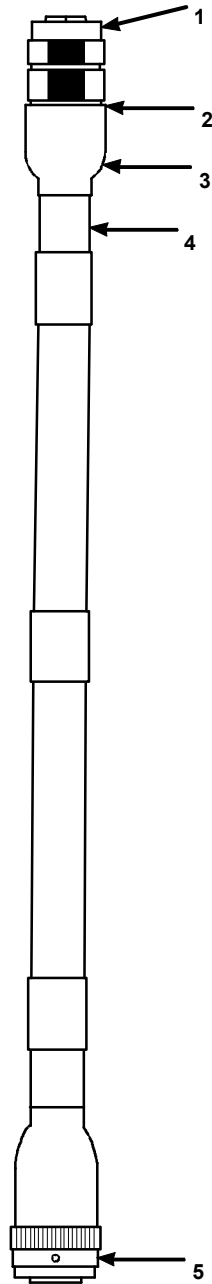
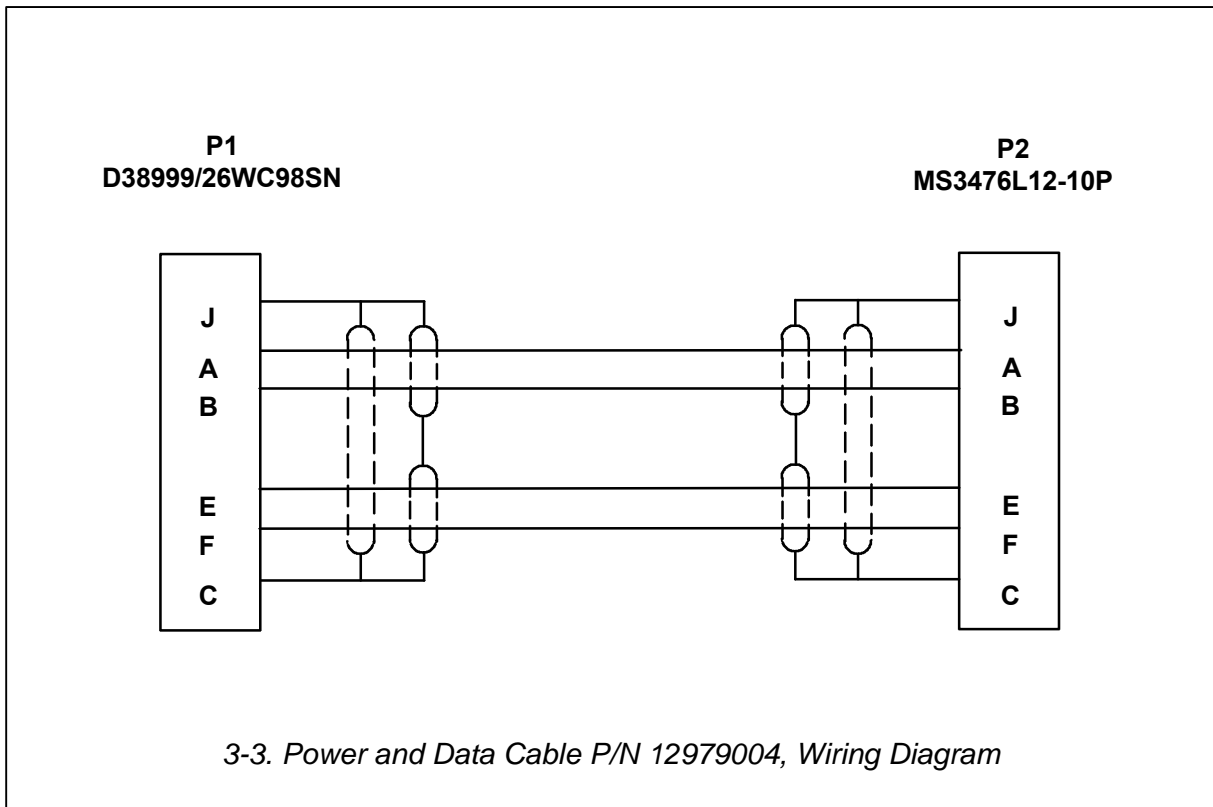
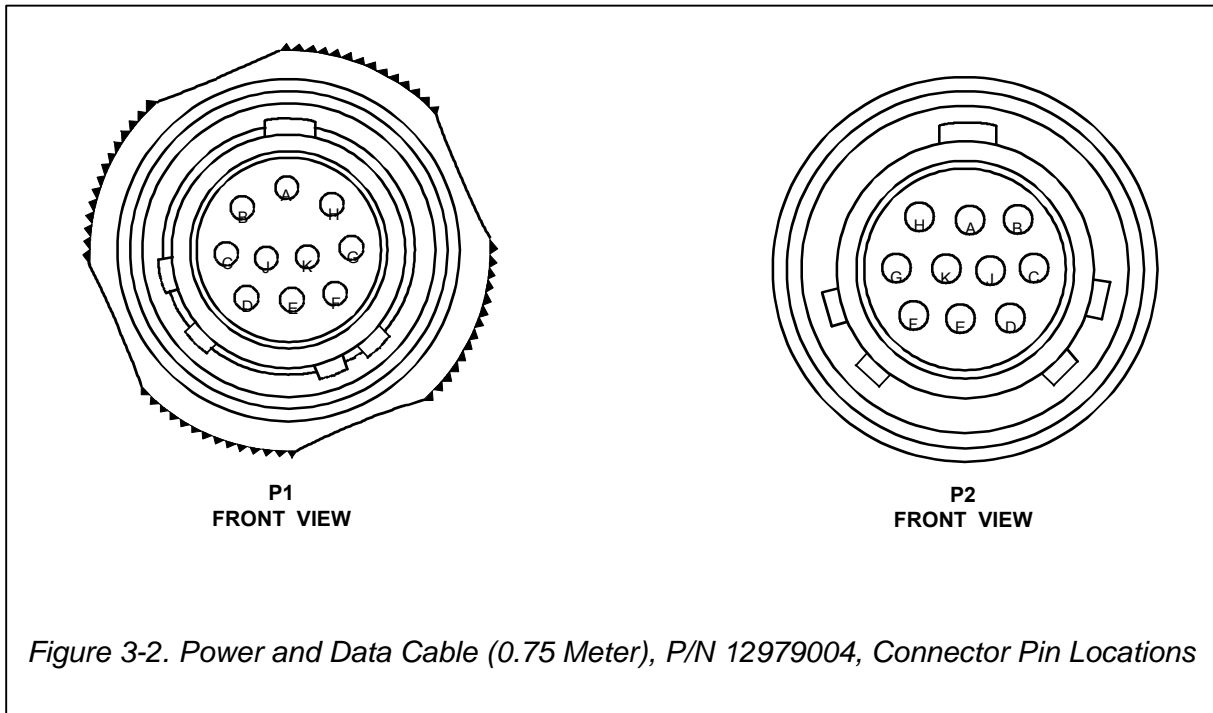

Figure 3-1. Power and Data Cable (0.75-Meter), P/N 12979004



SECTION III. POWER AND DATA CABLE (5-METER),

P/N 12991852

Section Contents

Subject	Page
General .....	3-13
Test Equipment and Special Tools .....	3-13
Materials Required .....	3-14
General Repair Requirements .....	3-14
Inspection.....	3-15
Electrical Test .....	3-15
Fault Isolation Table.....	3-20
1553 Stub Repair Procedures.....	3-22

**3.3. POWER AND DATA CABLE (5-METER), P/N 12991852**

**3.3.1 General.** The following paragraphs provide repair procedures and maintenance information for the M93 MVS Power and Data Cable (5-Meter), P/N 12991852. Source, maintenance, and recoverability code is PAODD.

**3.3.2 Test Equipment and Special Tools Required.** Test equipment and special tool requirements are listed in Table 3-7. Unless otherwise specified, the test equipment and special tools listed below will be used for testing the Power and Data Cable (5-Meter). Each commercially available item of test equipment can be replaced by equipment equivalent to that listed.

*Table 3-7. Test Equipment and Special Tools Required*

Nomenclature	Part/Spec. No.	Appendix C Figure 11 Item No.
Belt Wrench	Bertsch Co. No.1, Model 31335	18
Crimping Tool	Daniels, Model M22520/1-01	7
Crimping Tool Die	Daniels, Model M22520/1-02	10
Digital Multimeter	Fluke, Model 77-2	5
Electronic Equipment Tool Kit	PPL863	11
Heat Gun	Master-Mite, model 10008	4
Insertion/Extraction Tool	M81969/14-02	2
Power Supply, DC (0-40 , 3 A)	Lambda, LK-342-A-FM	15
Function Generator	Hewlett Packard, Model HP3325A	16
Oscilloscope	Hewlett Packard, Model HP1070B	17
Tester	RSL, P/N AY6707984-0	14

**3.3.3 Materials Required.** Repair materials and other consumable item requirements are listed in Table 3-8.

*Table 3-8. Materials Required*

Nomenclature	Part/Spec. No.	Appendix F Item No.
Adhesive	S1184	3
Adhesive	S1125	2
Label	43-143	10
Primer	747-55	17
Primer	MIL-S-22473, Grade AA	20

**3.3.4 General Repair Requirements.** Refer to Figure 3-4. Repair or replace cable connectors as follows:

**CAUTION**

Using excess force when cutting boot may cause damage to wiring inside boot.

**NOTE**

Before replacing a connector, ensure that the replacement connector matches exactly the connector to be replaced.

- a. Using sharp knife, carefully cut boot (3).
- b. Pry boot (3), off of backshell (2) and cable (4).
- c. Using connector pliers (soft jaw), remove backshell (2) from connector body (1 ) and slide away from connector (1).
- d. Tag and label wires.
- e. Using pin extractor tool, remove damaged pin and wire from connector body. Remove serviceable pins and wires also to facilitate installation of new boot (3).
- f. Remove connector (1) from cable (4).
- g. Move backshell (2) away from end of cable (4).
- h. Cut wire as close as possible to end of damaged pin.
- i. Strip insulation from wire as required to ensure that wire will seat properly in pin. Using crimping tool, crimp pin to wire.

**NOTE**

Failure to place heat shrink and backshell on cable at this point and in correct sequence will require later removal of connector from cable to facilitate install on of boot and backshell.

- k. Slide new boot (3) on cable (4).
- l. Using insertion tool, insert pins into connector body (1).

**NOTE**

Failure to perform continuity check at this point may require complete disassembly of connector to correct improperly terminated connector pins.

- m. Perform continuity test of cable in accordance with para. 3.3.6. If cable checks good, proceed to step n.
- n. Using small brush, clean sealing compound residue from threads of connector body (1 ) and backshell (2).
- o. Apply primer to threads of connector body (1 j and backshell (2).
- p. Apply sealing compound to threads of connector body (1 ) and backshell (2).
- q. Screw backshell (2) on connector body (1) and torque to 3.7 in. lb (5 N.m).
- r. Apply S1184 adhesive to inside of boot (3) to bond with cable shield and backshell (2).
- s. Apply S1125 adhesive inside of boot (3) for bonding to cable jacket (4) and backshell (2).
- t. Place boot (3) on backshell (2).
- u. Using heat gun, apply heat uniformly to boot (3) until boot shrinks to form secure seal around backshell (2) and cable (4).

**3.3.5 Inspection.** Refer to Figure 3-4. Inspect Power and Data Cable (5-Meter) as follows:

- a. Inspect all parts for damage, wear and deterioration.
- b. Inspect all wiring for bent or broken leads; cracked, frayed, deteriorated, worn, overheated, or burned insulation and security of attachment.
- c. Inspect connectors for broken, bent, recessed, loose, damaged or missing pins.

**3.3.6 Electrical Test.**

3.3.6.1 TEST SETUP. Refer to Figure 3-5. Connect test setup as follows:

- a. Set power supply to  $5 \pm 0.5$  VDC.
- b. Turn off power supply.

**NOTE**

J3 turns counter clockwise to secure plug P3 of cable to tester.

- c. Connect cable to Tester.
- d. Connect oscilloscope to SCOPE entry in Tester.
- e. Connect function generator to FUNCTION GEN entry in Tester.
- f. Connect Power Supply to tester in correct polarity.

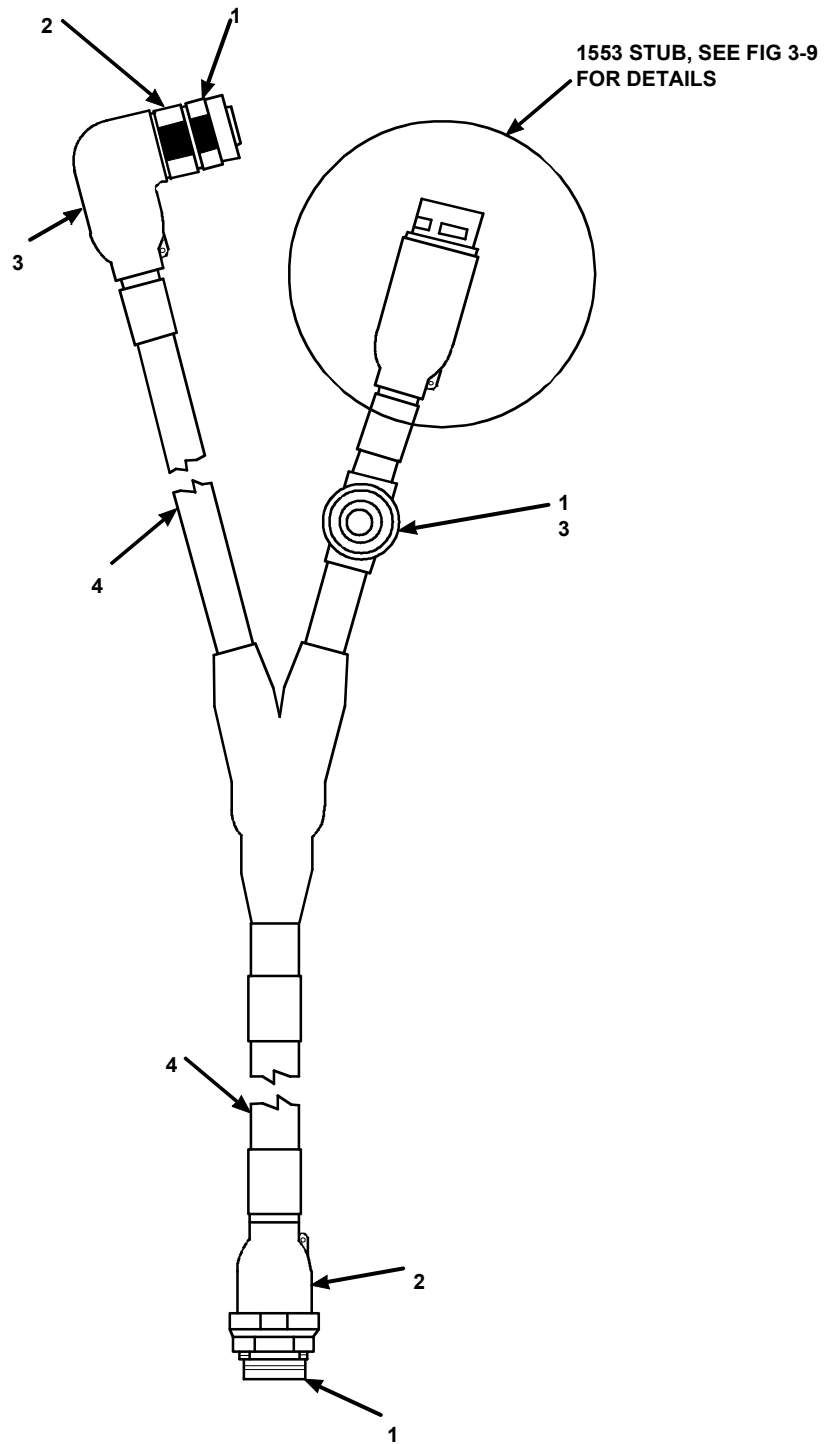

Figure 3-4. Power and Data Cable (5-Meter), P/N 12991852



3.3.6.2 TEST PROCEDURE. Refer to Figures 3-5, 3-6, 3-7, and 3-8. Check cable as follows:

- a. Verify Tester is OFF
- b. Set DMM to resistance mode.
- c. Measure self-resistance of DMM.
- d. Make sure to subtract DMM self-resistance from result.
- e. Connect DMM between TP5 and TP6.
- f. Set S1 to position A. Verify resistance is less than 1.0  $\Omega$ .
- g. Set S1 to position B. Verify resistance is less than 1.0  $\Omega$ .
- h. Set S1 to Position C. Verify resistance is less than 1.0  $\Omega$ .
- i. Set S1 to position E. Verify resistance is less than 1.0  $\Omega$ .
- j. Set S1 to position F. Verify resistance is less than 1.0  $\Omega$ .
- k. Set S1 to position A.
- l. Turn power supply on. Turn Tester on.
- m. Verify only LED A is on.
- n. Set S1 to position B. Verify only LED B is on.
- o. Set S1 to position C. Verify only LEDs C1 and C2 are on.
- p. Set S1 to position E. Verify only LEDs E and F are on.

#### NOTE

Oscilloscope and function generator must NOT both be grounded at their 115V power input or the LEDs of E and F remain "ON" in "IDLE" position.

- q. Set S1 to position F. Verify only LEDs E and F are on.
- r. Set S1 to position idle. Verify no LED is on.
- s. Turn off power supply.
- t. Measure resistance between TP6 and TP5. Verify resistance measured is  $2 \pm 1.25 \Omega$ .
- u. Measure resistance between TP4 and TP2. Verify resistance measured is  $114.5 \pm 1.5 \Omega$ .
- v. Set function generator to square wave of 1 MHz and  $20 \pm 0.5$  Vp-p amplitude.
- w. Measure signal with scope. Verify square wave amplitude is  $28 \pm 0.75$  Vp-p and frequency is  $1 \text{ MHz} \pm 1 \text{ Hz}$ .
- x. End of test.

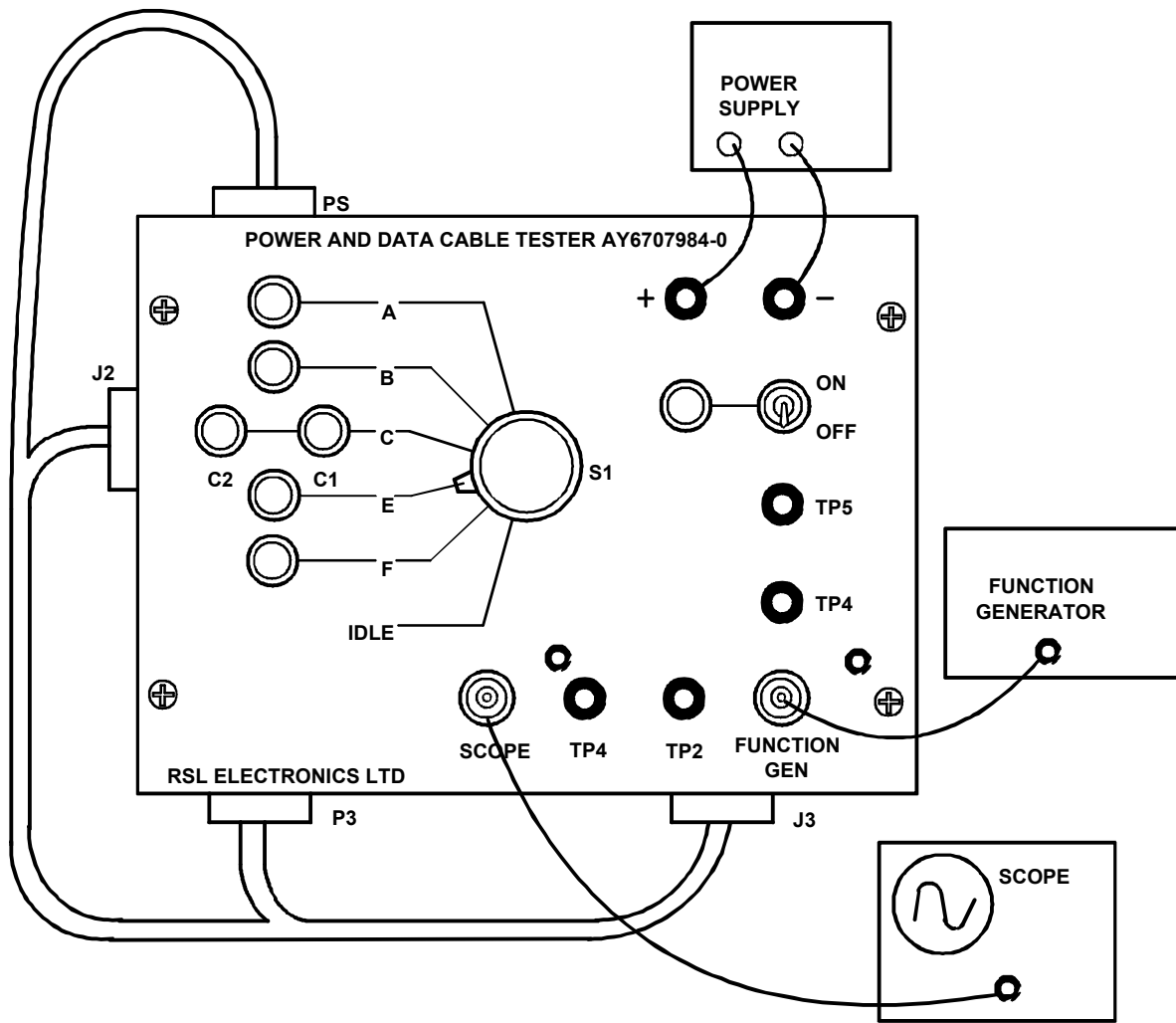

Figure 3-5. Power and Data Cable Test Setup

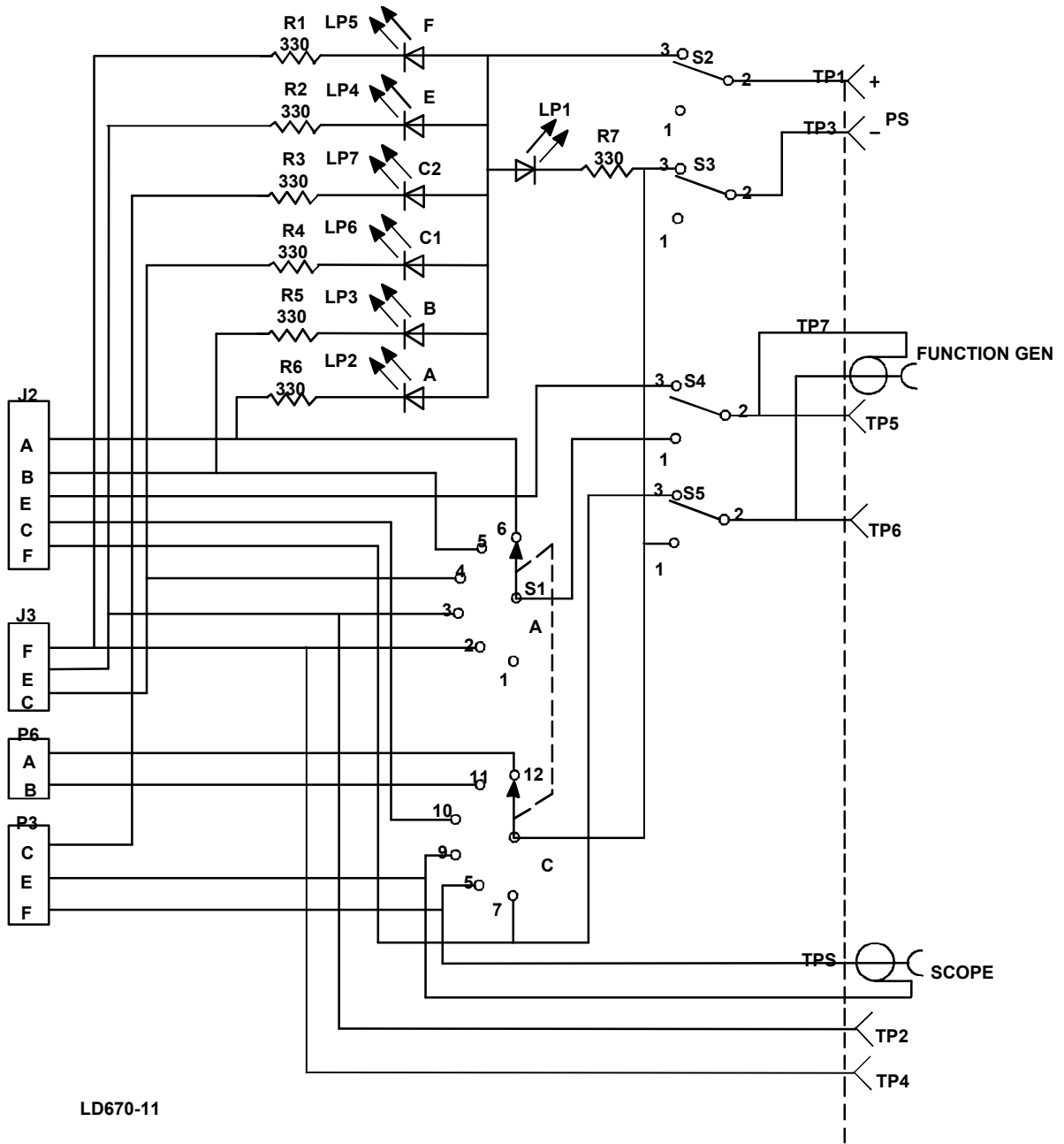
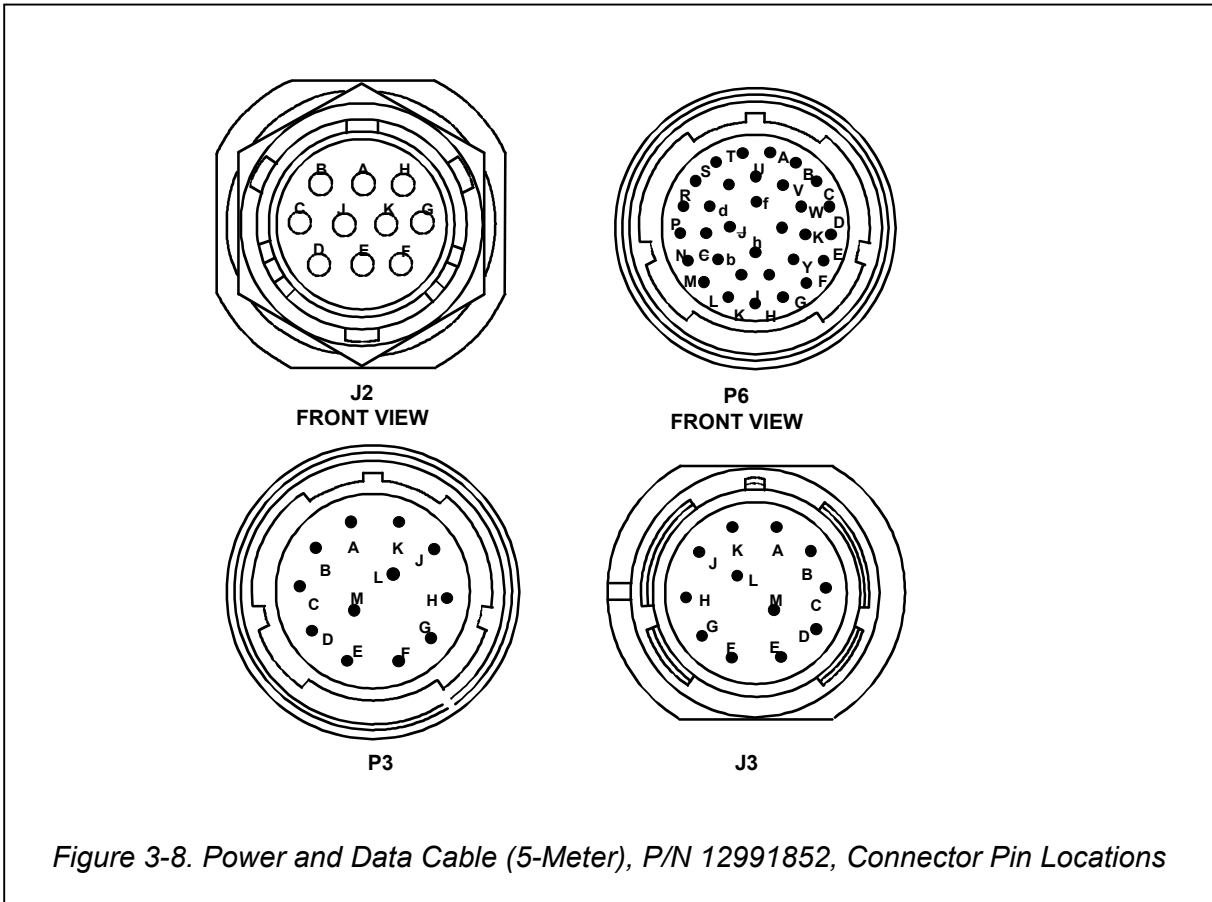
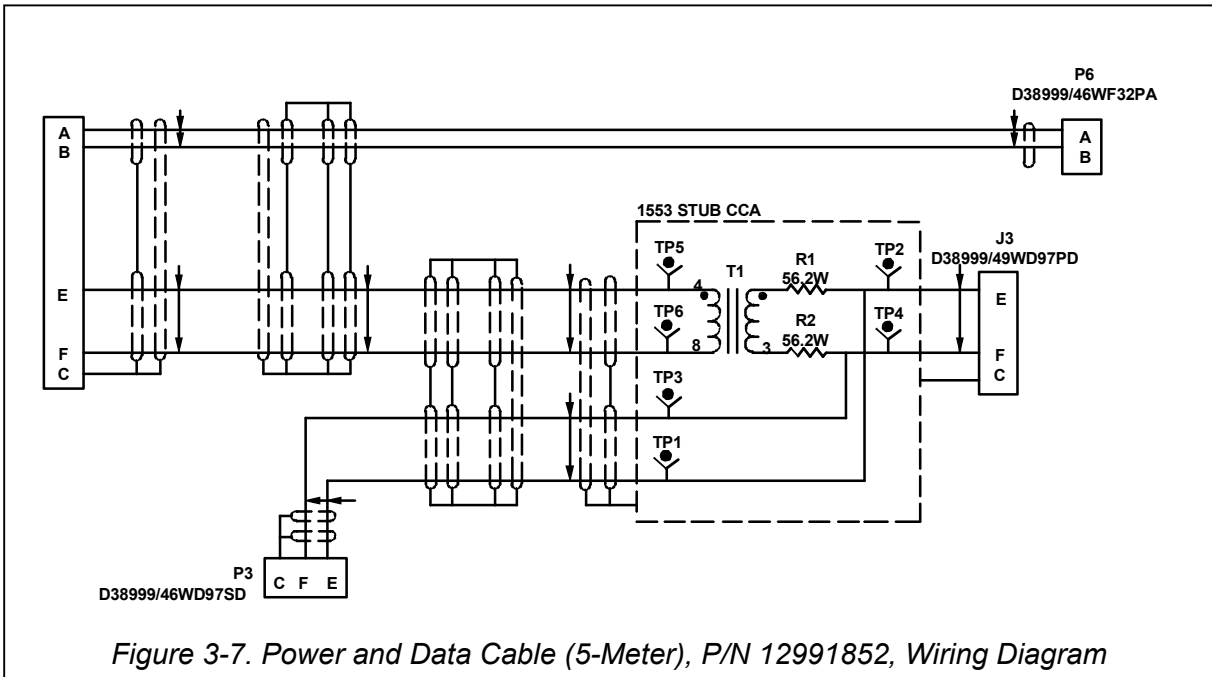

Figure 3-6. Power and Data Cable Tester, P/N AY6707984-0, Schematic Diagram

3.3.7 Fault Isolation Table. Refer to Figures 3-7 and 3-8.

Table 3-9. Fault Isolation Table

Fault at Para. 3.3.6.2 step	Fault Connectors Pin and Wiring	Repair Procedure
f.	J2/A - P6/A	Check and replace J2 or P6 connector
g.	J2B - P6B	Check and replace J2 or P6 connector
h.	J2/C - J3/C	Check and replace J2 or J3 connector
i.	J3/E - P3/E	Check and replace J3 or P3 connector
j.	J3/F - P3/ F	Check and replace J3 or P3 connector
m.	J2/A,B or P6/A,B	Check and replace J2 or P6 connector
n.	J1/A,B or P6/A,B	Check and replace J2 or P6 connector
o.	J2/C or J3/C or P3/C	Only C1 on. Check and replace P3. Only C2 ON. Check and replace J3 both are off. Check and replace J2.
P.	J3/E,F P3/E,F 1553 Stub (see para. 3.3.8)	Check and replace J3, P3 or 1553 Stub (see para. 3.3.8)
q.	J3/E,F P3/E,F 1553 Stub (see para. 3.3.8)	Check and replace J3, P3 or 1553 Stub (see para. 3.3.8)
r.	J2/A,B,E,F,C	Check and replace J2 connector
t.	J2/E,F 1553 Stub T1 (see para. 3.3.8)	Check and replace J2 connector or 1553 Stub T1 (see para. 3.3.8)
u.	J3/E,F 1553 Stub T1 or R1, R2 (see para. 3.3.8)	Check and replace J3, P3 or 1553 Stub T1, R1, or R2 (see para. 3.3.8)
w.	1553 Stub T1 (see para. 3.3.8)	Check and replace 1553 Stub T1 (see para. 3.3.8)



**3.3.8 1553 Stub Repair Procedures.** Refer to Figure 3-9. Assembly and disassembly as follows:

3.3.8.1 DISASSEMBLY Disassemble 1553 stub as follows:

**CAUTION**

Using excess force when cutting boot may cause damage to wiring inside boot.

- a. Using sharp knife, carefully cut boot (1).
- b. Pry boot off 1553 Stub and cable.
- c. Remove three screws (3) from 1553 Stub (2).
- d. Pull out carefully 1553 CCA (4).
- e. Tag and label wires.
- f. Disconnect by soldering TP1, TP3, TP5, and TP6.
- g. Unscrew carefully connector body (5) from 1553 Stub (2).
- h. Tag and label wires.
- i. Use pin extraction tool to remove connector (5) J3 pins.
- j. Pull out 1553 CCA (4).
- k. Remove two screws (6) from 1553 CCA (4).
- l. Replace damaged part T1 or R1, R2, as necessary.

3.3.8.2 ASSEMBLY. Assemble 1553 stub as follows:

- a. Attach 1553 CCA (4) to 1553 Stub (2).
- b. Attach terminal lug and fasten two screws (6).
- c. Push in 1553 CCA (4).
- d. Using insertion tool, insert pins into connector J3 body (5).
- e. Apply primer to threads of connector body (5) and 1553 Stub (2).
- f. Apply sealing compound to threads of connector body (5) and 1553 Stub (2).
- g. Fasten carefully connector body (5) to 1553 Stub (2).
- h. Slide new boot on cable.
- i. Pull out carefully 1553 Stub and connect by soldering TP1, TP3, TP5, and TP6.
- j. Push in 1553 CCA (4).
- k. Fasten three screws (3).
- l. Apply S1184 adhesive to inside of boot (1) to bond with cable shield and 1553 Stub (2).
- m. Apply S1125 adhesive to outside of boot (1) for bonding to cable jacket and 1553 Stub (2).
- n. Place boot (1) on 1553 Stub (2).
- o. Using heat gun to apply heat uniformly to boot (1) until boot shrinks to form secure seal around 1553 Stub (2) and cable.

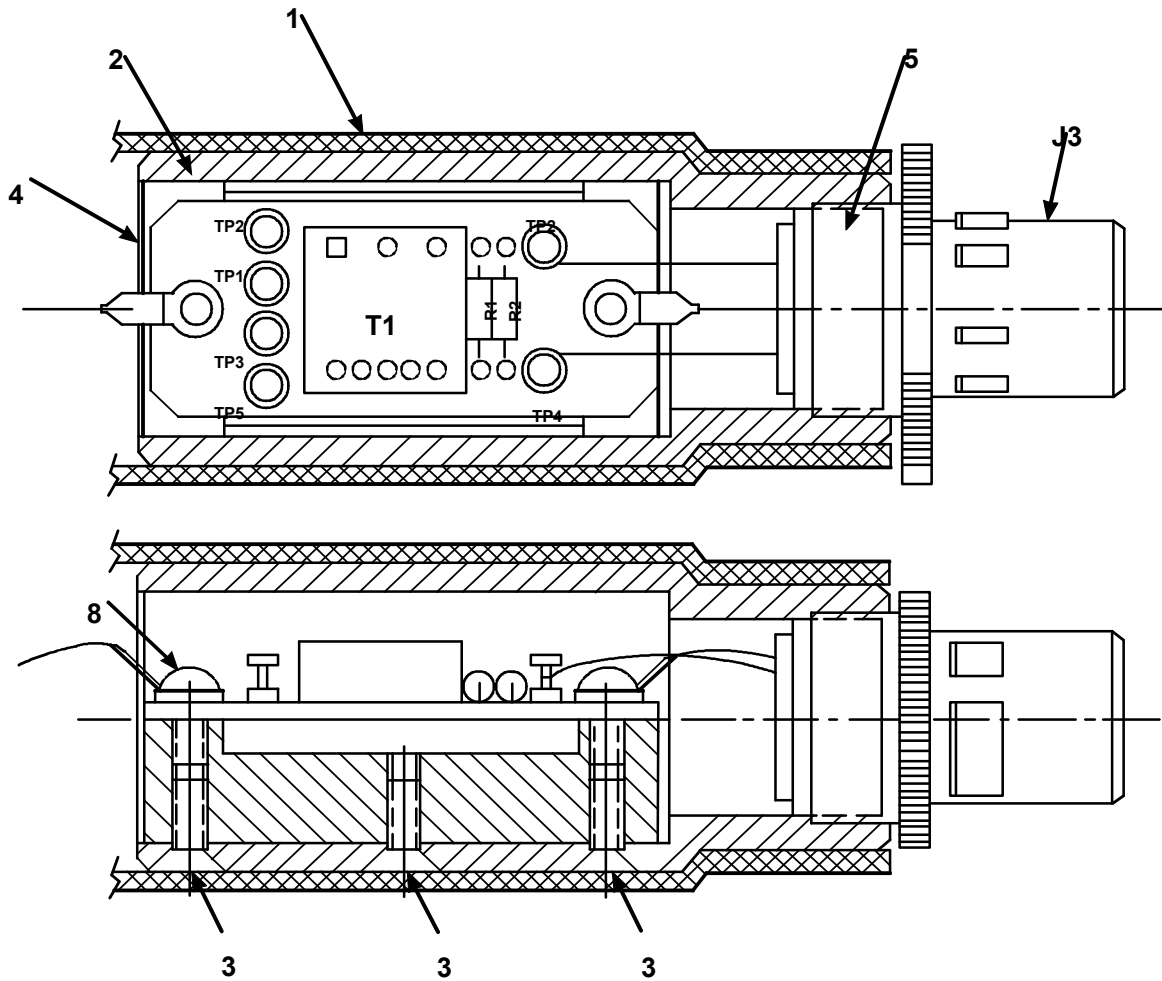

Figure 3-9. 1553 Stub (Part of Power and Data Cable (5-M), P/N 12991852)





**SECTION IV. 1553 TERMINATION,  
P/N 12979006**

**Section Contents**

<b>Subject</b>	<b>Page</b>
General.....	3-25
Test Equipment and Special Tools Required .....	3-25
Materials Required .....	3-26
General Repair Requirements.....	3-26
Inspection .....	3-27
Continuity Test .....	3-27
Removal .....	3-27
Installation .....	3-27

---

**3.4. 1553 TERMINATION, P/N 12979006**

**3.4.1. General.** The following paragraphs provide repair procedures and maintenance information for the M93 MVS 1553 Termination, P/N 12979006. Source, maintenance, and recoverability code is PAOZZ.

**3.4.2. Test Equipment and Special Tools Required.** Test equipment and special tool requirements are listed in Table 3-10. Unless otherwise specified, the test equipment and special tools listed below will be used for testing the 1553 Termination. Each commercially available item of the test equipment can be replaced by equipment equivalent to that listed.

*Table 3-10. Test Equipment and Special Tools Required*

<b>Nomenclature</b>	<b>Part/Spec. No.</b>	<b>Appendix C Figure 11 Item No.</b>
Belt Wrench	Bertsch Co. No. 1, Model 31335	18
Crimping Tool	Daniels, Model M22520/1-01	7
Contact Positioner	Daniels, Model M22520/1-02	10
Digital Multimeter	Fluke, Model 77-2	5
Electronic Equipment Tool Kit	PPLB63	11
Heat Gun	Master-Mite, Model 10008	4
Insertion/Extraction Tool	M81969/14-02	2

**3.4.3. Materials Required.** Repair materials and other consumable item requirements are listed in Table 3-11.

*Table 3-11. Materials Required*

<b>Nomenclature</b>	<b>Part/Spec. No.</b>	<b>Appendix f Item No.</b>
Adhesive	S1184	3
Adhesive	S1125	2
Label	43-143	10
Primer	747-55	17
Primer	MIL-S-22473, Grade AA	20
Insulating Tube	M22129CLR22AWG	25
Resistor	75 ohms, 1%	28

**3.4.4. General Repair Requirements.** Refer to Figure 3-10. Repair or replace connector as follows:

**NOTE**

The following procedure applies to connector P1.

**NOTE**

Before replacing a connector, ensure that the replacement connector matches exactly the connector to be replaced.

- a. Using connector pliers (soft jaw), remove shorting cap (1) from connector body (2) and slide away from connector (2).
- b. Tag and label wires.
- c. Using pin extraction tool, remove damaged pin and wire from connector body (2).
- d. Using crimping tool, crimp pin to 75 ohm fixed film resistor lead. Cover with insulating tube.
- e. Using insertion tool, insert pins into connector body (2).

**NOTE**

Failure to perform continuity check at this point may require complete disassembly of connector to correct improperly terminated connector pins.

- f. Perform continuity test of cable in accordance with para. 3.4.6. If cable checks good, proceed to step g.
- g. Using small wire brush, clean sealing compound residue from threads of connector body (2) and shorting cap (1).
- h. Apply primer to threads of connector body (2) and shorting cap (1).
- i. Apply sealing compound to threads of connector body (2) and shorting cap (1).
- j. Install shorting cap (1) on connector body (2) and torque to 3.7 ft lb (5 N.m).

**3.4.5. Inspection.** Refer to Figure 3-10. Inspect 1553 Termination as follows:

- a. Check all parts for damage, wear and deterioration.
- b. Check all wiring for bent or broken leads; cracked, frayed, deteriorated, worn, overheated, or burned insulation and security of attachment.
- c. Check connector for broken, bent, recessed, loose, damaged or missing pins.
- d. Check protective cap for security of attachment.

**3.4.6. Continuity Test.**

- a. Check with DMM resistance between P1/F and P1/E.
- b. Verify resistance is 75 ohms  $\pm$ 1.0.

**3.4.7. Removal.**

- a. Loosen attaching parts of 1553 Termination securing wire to gun.
- b. Detach 1553 Termination from mating dummy connector on gun by loosening 1553 Termination connector.

**3.4.8. Installation.**

- a. Attach 1553 Termination to dummy connector on gun.
- b. Install securing wire of 1553 Termination to gun using attaching parts.

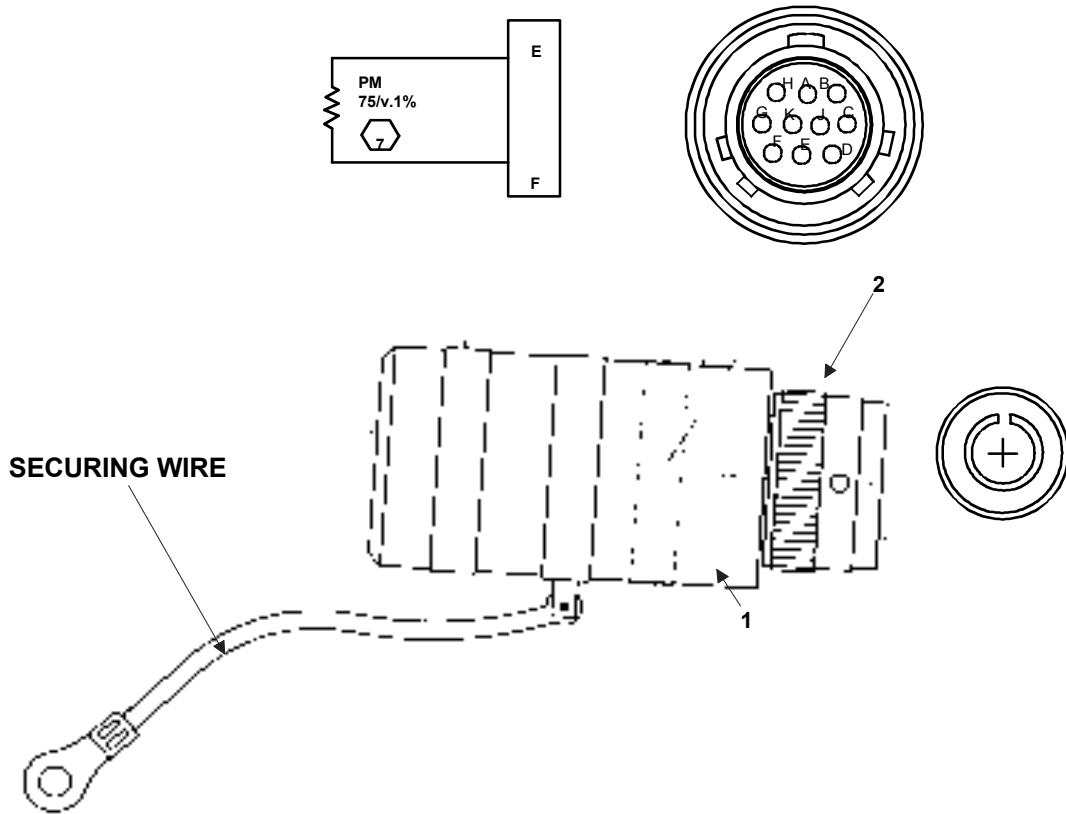

Figure 3-10. 1553 Termination, P/N 12979006

SECTION V. BRACKET ASSEMBLY, P/N 12979003

Section Contents

Subject	Page
General.....	3-29
Special Tools Required .....	3-29
Materials Required .....	3-29
Inspection.....	3-30
Disassembly .....	3-30
Assembly.....	3-30
Removal of Bracket from Transceiver Assy.....	3-30
Installation of Bracket from Transceiver Assy.....	3-30

---

**3.5. BRACKET ASSEMBLY, P/N 12979003.**

**3.5.1. General.** The following paragraphs provide repair procedures and maintenance information for the M93 MVS Bracket Assembly, P/N 12979003. Source, maintenance, and recoverability code is PA000.

**3.5.2. Special Tools Required.** Special tool requirements are listed in Table 3-12. Unless otherwise specified, the special tools listed below will be used for repairing the Bracket Assembly. Each commercially available tool can be replaced by a tool equivalent to that listed.

*Table 3-12. Special Tools Required*

Nomenclature	Part/Spec. No.	Appendix C Figure 11 Item No.
Torque Wrench	T530	6

**3.5.3. Materials Required.** Repair materials and other consumable item requirements are listed in Table 3-13.

*Table 3-13. Materials Required*

Nomenclature	Part/Spec. No.	Appendix F Item No.
Lockwasher	M535338-137	24

**3.5.4. Inspection.** Inspect Bracket Assembly as follows:

- a. Inspect all components for security of attachment.
- b. Inspect all parts for damage, wear, and deterioration.
- c. Inspect all parts for nicks, scoring, dents, scratches, and broken welds.
- d. Inspect all threaded parts for crossed, stripped, or otherwise damaged threads.
- e. Inspect threaded inserts and nutplates for security of attachment.
- f. Inspect painted surfaces for cracked, chipped, blistered, or deteriorated paint film.

**3.5.5. Disassembly.** Refer to Figure 3-11. Disassemble Bracket Assembly as follows:

- a. Remove four screws (6), four lockwashers (7), and four flat washers (8) on each of the four resilient mounts (5) from machined bracket (4). Discard lockwashers (7).
- b. Unscrew and remove externally-relieved bolt (1), lockwashers (2) and round plain nut (3) from machined bracket (4).

**3.5.6. Assembly.** Refer to Figure 3-11. Assemble Bracket Assembly as follows:

- a. Insert lockwasher (3) and round plain nut (2) on externally relieved bolt (1).
- b. Screw externally relieved bolt (1) into machined bracket (4).
- c. Position four resilient mounts (5) on machined bracket (4) and secure each with four flat washer's (8), four new lockwashers (7), and 4 screws (6). Torque machine screws (6) to 9.8-10.8 in. lb (1.11-1.22 N.m).

**3.5.7. Removal of Bracket from Transceiver Assy.** Refer to Figure 3-12.

- a. Remove four hex socket screws (1 ) and four lockwashers (2).
- b. Remove Bracket Assy (3) from Transceiver Assy (4).

**3.5.8. Installation of Bracket from Transceiver Assy.** Refer to Figure 3-12.

- a. Attach Bracket Assy (3) and Transceiver Assy (4).
- a. Install four hex socket screws (1) and four lockwashers (2).

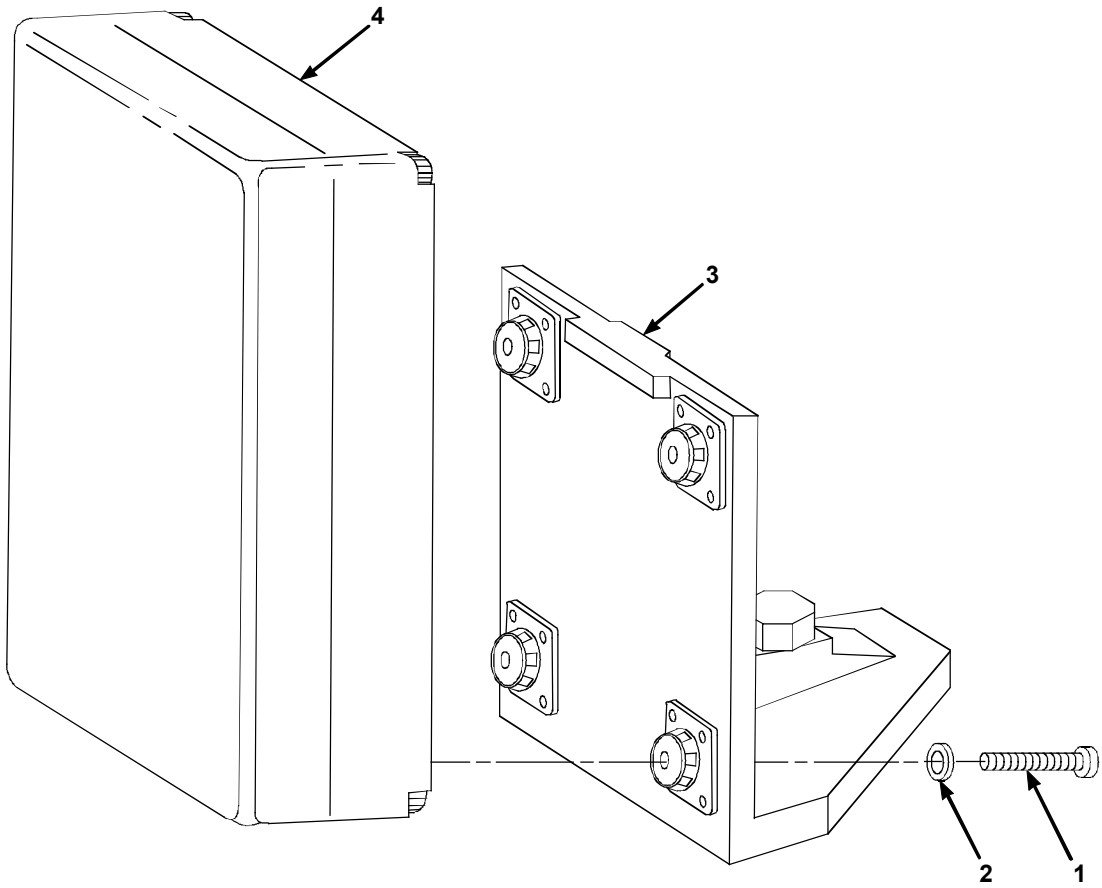

Figure 3-11. Bracket Assembly, P/N 1297003

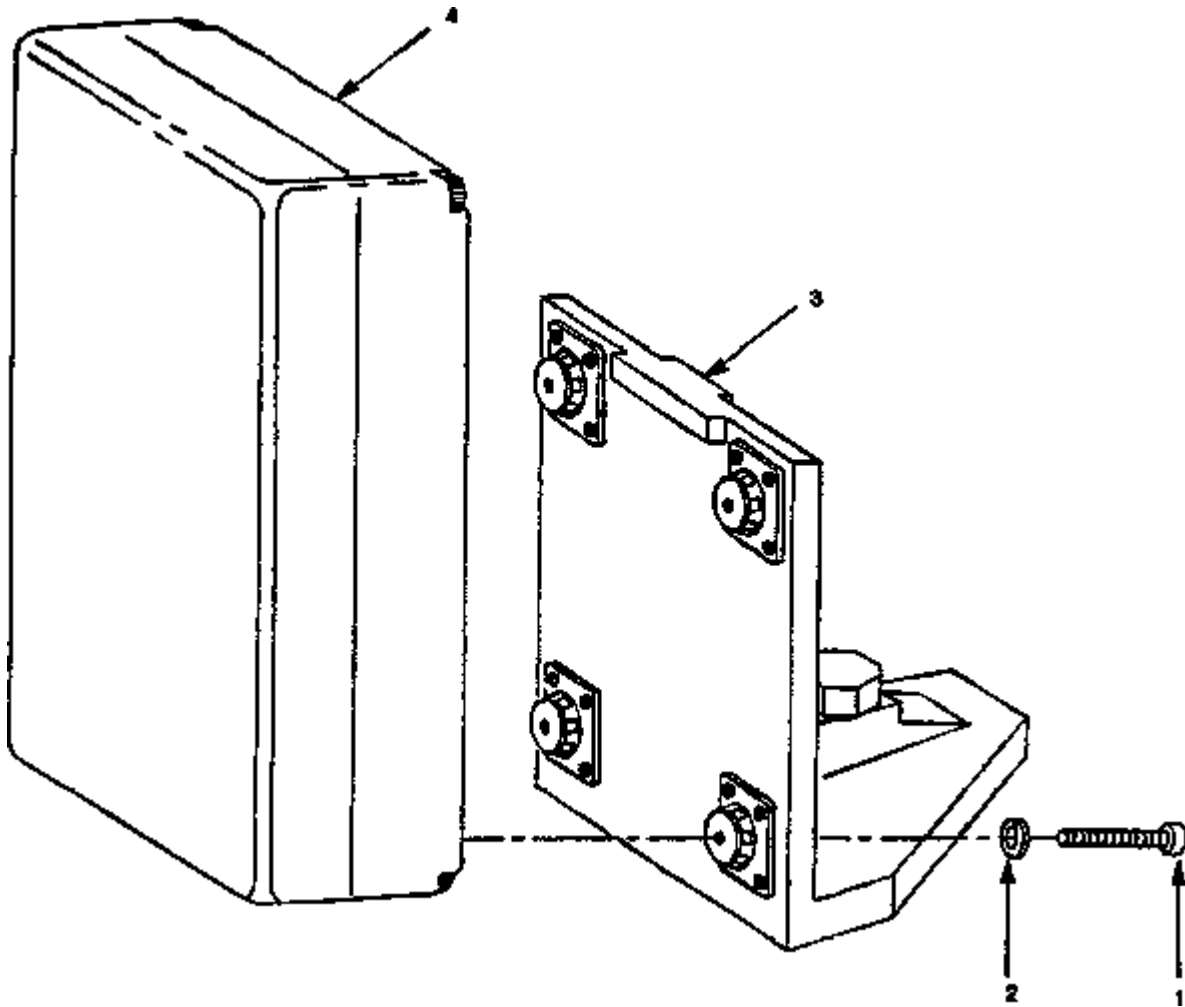

Figure 3-12. Antenna Transceiver & Bracket Assy, P/N AY6709351-4, Removal and Installation



SECTION VI. TRANSCEIVER ASSEMBLY,

P/N 13002074

Section Contents

Subject	Page
General .....	3-33
Removal.....	3-33
Installation.....	3-33

---

**3.6. TRANSCEIVER ASSEMBLY, P/N 13002074**

**3.6.1. General.** The following paragraphs provide removal and installation procedures for the M93 MVS, Transceiver Assembly, P/N 13002074. Source, maintenance, and recoverability code is PAODD.

**3.6.2. Removal.** Refer to Figure 3-12. Remove Transceiver Assy as follows:

- a. Remove four screws (1 ) and four lockwashers (2) using 5-mm hex key wrench.
- b. Remove Transceiver Assy (4) from Bracket Assy (3).

**3.6.3. Installation.** Refer to Figure 3-12. Install Transceiver Assy to Bracket Assy as follows:

- a. Attach Transceiver Assy (4) to Bracket Assy (3).
- a. Install four screws (1 ) and four lockwashers (2) using 5-mm hex key wrench.

**3.6.4. Disposition.** The Item Manager for the M93/M94 MVS provides 'Disposition' instructions for serviceable/unserviceable spares, repairs or end item components. The procedure is outlined in AR 725-50, Chapter 7, Nov 95 regarding submission of the item for repair. Any failed item should be sent back to Borisch Manufacturing Corp. for repair/replacement. An FTE is required for any returned items. The contract is DAAE20-98-C-0089. The repair facility associated with the contract is:

Borisch Manufacturing Corporation  
 4511 East Paris Se  
 Grand Rapids, MI 49512

DODACC: CMASD8  
 RIC: CCA

Depending on the severity of the failure, it can take a maximum of three working weeks. If the failure can't be repaired, the item must be replaced with a new one at the unit's expense. There is no warranty for the MVS.



**CHAPTER 4**  
**UNPACKING AND INSTALLATION**

---

**CHAPTER CONTENTS**

<b>Subject</b>	<b>Page</b>
General.....	4-1
Unpacking.....	4-1
Installation.....	4-1
Installation of Transceiver Assy on Gun .....	4-2
System Interconnection.....	4-2

---

**4.1 GENERAL.**

This chapter describes procedures required for proper unpacking and installation of the M93 MVS.

**4.2 UNPACKING.**

- a. Open packaging and verify that all parts are present. Refer to Table 1-1 and Figure 1-1.
- b. Inspect Transceiver Assy and verify:
  - (1) No external mechanical damage to Transceiver housing.
  - (2) No connector pins are bent or broken.
  - (3) Transceiver Assy is properly fastened to Mounting Bracket Assy. If necessary, tighten four screws using 5-mm hex key wrench.
- c. Inspect cables and verify:
  - (1) No external mechanical damage.
  - (2) No connector pins are bent or broken.

**NOTE**

Remember to place dust caps on connectors when not in use.

**4.3 INSTALLATION.**

Refer to Figure 4-1. Installation of the system units is performed in the following steps:

- a. Install Transceiver Assy with connected Mounting Bracket Assy on non-recoiling part of gun.
- b. System interconnection.

#### 4.3.1 Installation of Transceiver Assy on Gun.

- a. Place Bracket Assy (with Transceiver Assy already mounted) on its position on gun.
- b. Using hex socket wrench, tighten the bracket 1/2" screw.
- c. Verify Transceiver Assy is properly fastened to gun bracket.
- d. Verify Transceiver Assy is properly mounted to Mounting Bracket Assy and all screws are fastened.

#### 4.3.2 System Interconnection.

- a. Verify AFCS Power switch is in OFF position.
- b. Connect Transceiver Assy to 5-meter Power and Data Cable using 0.75-meter Power and Data Cable. (See Figure 1-2.)

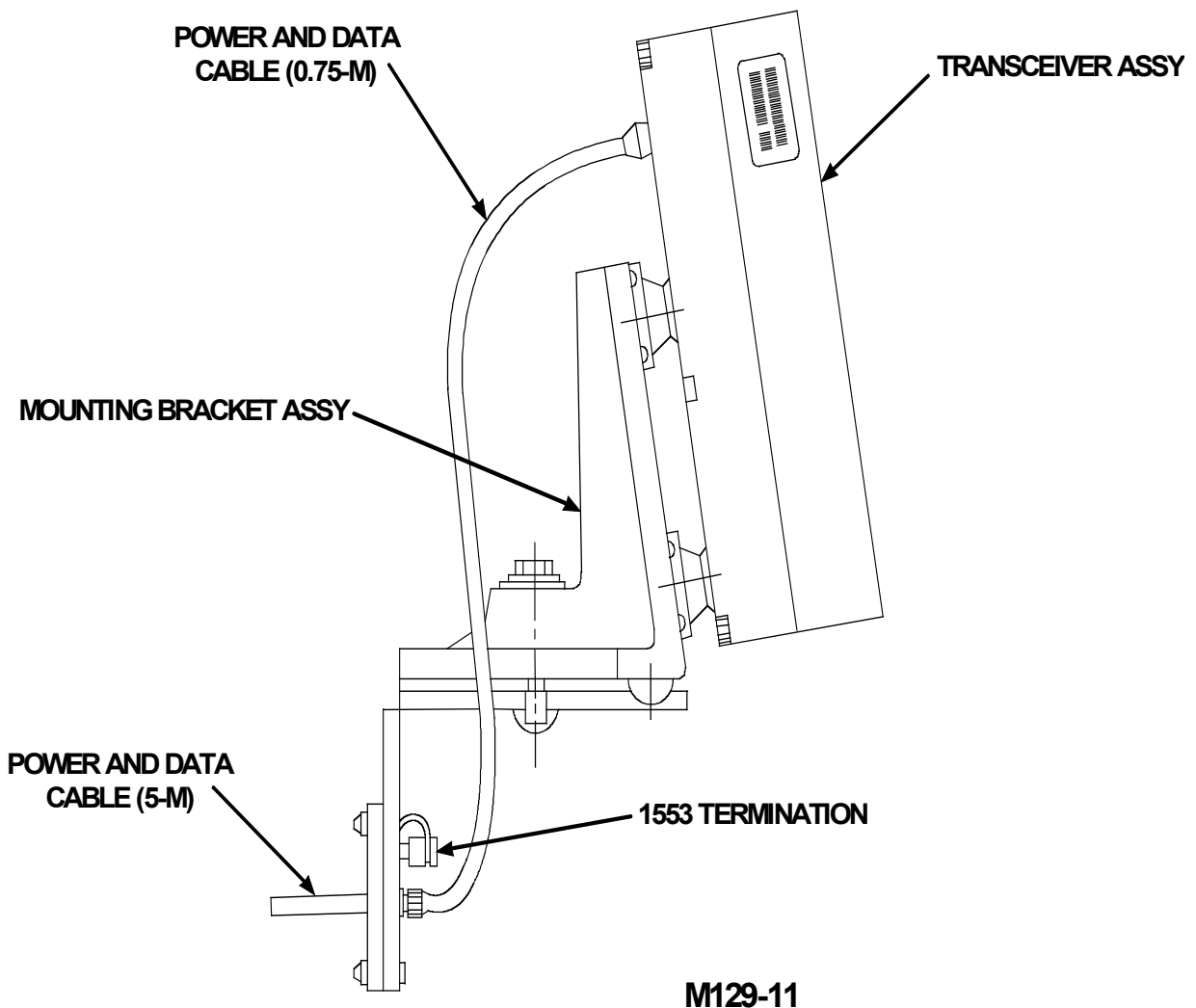

Figure 4-1. M93 MVS Installation

**CHAPTER 5**  
**PREPARATION FOR SHIPMENT**

**CHAPTER CONTENTS**

<b>Subject</b>	<b>Page</b>
General .....	5-1
Shipping M93 MVS In Crates.....	5-1
Packing and Shipping M93 Units and Parts.....	5-1

**5.1 GENERAL.**

Before shipping the M93 MVS, ensure that it is operating satisfactory. If the M93 MVS operation is not satisfactory, make a list of faults or symptoms. The M93 MVS may be shipped in a crate.

**5.2 SHIPPING M93 MVS IN CRATES.**

- a. Select wooden crate large enough to hold system and packing material.
- b. Pack MVS units IAW steps a. thru f. of para. 5.3.
- c. Place packing material to crate box level.
- d. Seal crate.
- e. Mark crate in accordance with MIL-STD-129.
- f. The M93 MVS is now ready for shipping.

**5.3 PACKING AND SHIPPING M93 UNITS AND PARTS.**

- a. Verify that connector dust cap is securely fastened.
- b. Wrap unit with antistatic bubble sheets. Place extra bubble sheets on Transceiver radome face.
- c. Place unit in suitable, firm carton or box.
- d. Pad well with soft packing material. Verify that item will remain secure during shipment.
- e. Fill carton with packing material.
- f. Seal carton.
- g. Place in a heavy duty antistatic plastic bag and heat-seal the bag.
- h. Place sealed unit in a shipping container and mark IAW MIL-STD-129.
- i. The unit is now ready for shipping.



**CHAPTER 6**  
**STORAGE AND SHIPPING**

---

**CHAPTER CONTENTS**

<b>Subject</b>	<b>Page</b>
Preparation for Storage.....	6-1
Environment.....	6-1
Return to Service .....	6-1
Shipping .....	6-2

---

**6.1 PREPARATION FOR STORAGE.**

This chapter describes procedures required for storing the M93 MVS. Refer to TM 740-90-1 for instructions on placing the M93 MVS in administrative storage.

- a. Prior to storage, the M93 will be wiped clean with a Lint Free Cloth (Item 7, Appx.F) or with a Wiping Rag (Item18, Appx. F) dampened with Isopropyl Alcohol (Item 4, Appx. F).
- b. The Receiver-Transmitter microstrip antenna on the face of the antenna must be protected from damage with bubble wrap to prevent damage during storage or shipment.
- c. When stored in the howitzer, the antenna-bracket assembly will have the antenna face protected with bubble wrap and be secured in place with webstraps to prevent damage due to shifting of equipment during movement of the howitzer.
- d. When stored elsewhere, it should be stored in a cool, dry location if possible.

**6.2 ENVIRONMENT**

Once prepared for storage, the M93 MVS may be stored indefinitely in an environment suitable for electronic equipment. Maximum and minimum environmental conditions are as follows:

Maximum Temperature	+150° F
Minimum Temperature	-50° F
Relative Humidity	≥95%

**6.3 RETURN TO SERVICE.**

To return an M93 MVS to service after storage, perform the following procedures:

- a. Perform external inspection in accordance with para 3.1.4.
- b. Install the M93 MVS to the Paladin Automatic Fire Control System (AFCS) and verify proper operation. Refer to TM 9-2350-314-10.

#### **6.4 SHIPPING.**

Prior to shipment for repair, the Transmitter-Receiver will be packaged as follows:

- a. The transmitter-receiver will be removed from the bracket assembly to which it is attached by four Socket Head Screws, using a 5mm hex key wrench as shown in Section VI of this manual.
- b. It will be wiped clean as stated in the storage paragraph above, and wrapped in ESD protective bubble wrap.
- c. It will be placed in a protective cardboard box and cushioned with bubble wrap to prevent damage to the antenna face and the electrical connector during shipment.
- d. The bracket assembly and socket head screws will remain with the howitzer to be used for mounting the replacement antenna when it is received.



**APPENDIX A**

**REFERENCES**

**APPENDIX CONTENTS**

<b>Subject</b>	<b>Page</b>
General .....	A-1
Forms .....	A-1
Field Manuals.....	A-1
Technical Manuals .....	A-1
Miscellaneous Publications.....	A-2

**A.1 GENERAL.**

This appendix lists all the forms, field manuals, technical manuals, and miscellaneous publications referenced in this manual.

**A.2 FORMS.**

Recommended Changes to Publications and Blank Forms.....	DA Form 2028
Recommended Changes to Equipment Technical Publications .....	DA Form 2028-2
Equipment Inspection and Maintenance Worksheet.....	DA Form 2404
Maintenance Request.....	DA Form 2407
DOD Single Line Item Release/Receipt Document .....	DOD Form 1348-1
Report of Discrepancy (ROD) .....	SF Form 364
Product Quality Deficiency Report .....	SF Form 368

**A.3 FIELD MANUALS.**

Nuclear, Biological, Chemical (NBC) Decontamination .....	FM 3-5
Operation and Maintenance of Ordnance Materiel In Cold Weather (0° to -65° F).....	FM 9-207
First Aid for Soldiers.....	FM 21-11
Operating Under Unusual Conditions .....	FM 21-305

**A.4 TECHNICAL MANUALS.**

General Maintenance Procedures for Fire Control Materiel .....	TM 9-254
Painting Instructions for Army Materiel .....	TM 43-0139
Administrative Storage of Equipment.....	TM 740-90-1
Operator's Manual for M109A6 Paladin SPH.....	TM 9-2350-314-10
Organizational Maintenance Manual for M109A6 Paladin SPH .....	TM 9-2350-314-20-2

**ARMY TM 9-1290-365-24&P**

Organizational, Direct Support, General Support Repair Parts and  
Special Tool List for M109A6 Paladin SPH ..... TM 9-2350-314-24P-2  
Procedures for Destruction of Tank-Automated Equipment to Prevent  
Enemy Use (US Army Tank-Automotive Command)..... TM 750-244-6  
Equipment Record Procedures..... TM 4700-15/1  
ESD Awareness..... TM 9999-15/1  
ESD Awareness..... TM 9999-15/2

**A.5 MISCELLANEOUS PUBLICATIONS.**

Army Materiel Maintenance Policies ..... AR 750-1  
Army Medical Department Expendable/Durable Items ..... CTA 8-100  
Expendable/Durable Items (Except Medical, Class V, Repair Parts,  
and Heraldic Items)..... CTA 50-970  
Materiel Management for Using Units, Support Units, and Installations ..... DA PAM 710-2-1  
The Army Maintenance Management System (TAMMS)..... DA PAM 738-750  
US Army Equipment Index of Modification Work Orders ..... DA PAM 750-10

## APPENDIX B MAINTENANCE ALLOCATION CHART

---

### Section I. INTRODUCTION

#### B-1. GENERAL

a. This section provides a general explanation of all maintenance and repair functions authorized at various maintenance categories.

b. The Maintenance Allocation Chart (MAC) in Section II designates overall authority responsible for the performance of maintenance functions on the identified end item or component. The application of the maintenance functions to the end item or component will be consistent with the capacities and capabilities of the designated maintenance levels, which are shown on the MAC in Column (4) as:

Field – Includes two subcolumns, Unit (C (Operator/Crew) and O (Unit)) maintenance and Direct Support (F) maintenance.

Sustainment – Includes two subcolumns, General Support (H) and Depot (D) maintenance.

c. Section III lists the tools and test equipment (both special tools and common tools) required for each maintenance function as referenced from section II.

d. Section IV contains supplemental instructions and explanatory notes for a particular maintenance function.

**B-2. MAINTENANCE FUNCTIONS.** Maintenance functions will be limited to and defined as follows: (except for ammunition MAC<sup>1</sup>).

a. Inspect. To determine the serviceability of an item by comparing its physical, mechanical, and/or electrical characteristics with prescribed standards through examination (e.g. by sight, sound, or feel).

b. Test. To verify serviceability by measuring the mechanical, pneumatic, hydraulic, or electrical characteristics of an item and comparing those characteristics with prescribed standards.

c. Service. Operations required periodically to keep an item in proper operating condition, i.e., to clean (includes decontaminate, when required), to preserve, to drain, to paint, or to replenish fuel, lubricants, chemical fluids, or gases.

d. Adjust. To maintain or regulate, within prescribed limits, by bringing into proper or exact position, or by setting the operating characteristics to specified parameters.

e. Aline. To adjust specified variable elements of an item to bring about optimum or desired performance.

---

<sup>1</sup>Exception is authorized for ammunition MAC to permit the redesignation/redefinition of maintenance function headings to more adequately identify ammunition maintenance functions. The heading designations and definitions will be included in the appropriate technical manual for each category of ammunition.

**B-2. MAINTENANCE FUNCTIONS (cont)**

f. Calibrate. To determine and cause corrections to be made or to be adjusted on instruments or test, measuring, and diagnostic equipment used in precision measurement. Consists of comparisons of two instruments, one of which is a certified standard of known accuracy, to detect and adjust any discrepancy in the accuracy of the instrument being compared.

g. Remove/Install. To remove and install the same item when required to perform service or other maintenance functions. Install may be the act of emplacing, seating, or fixing into position a spare, repair part or module (component or assembly) in a manner to allow the proper functioning of an equipment or system.

h. Replace. To remove an unserviceable item and install a serviceable counterpart in its place. "Replace" is authorized by the MAC and is shown as the 3d position of the SMR code.

i. Repair. The application of maintenance services<sup>2</sup>, including fault location/troubleshooting<sup>3</sup>, removal/installation, disassembly/assembly<sup>4</sup> procedures, and maintenance actions<sup>5</sup> to identify troubles and restore serviceability to an item by correcting specific damage, fault, malfunction, or failure in part, subassembly, module (component or assembly), end item, or system.

j. Overhaul. That maintenance effort (service/action) prescribed to restore an item to a completely serviceable/operational condition as required by maintenance standards in appropriate technical publications (i.e., DMWR). Overhaul is normally the highest degree of maintenance performed by the Army. Overhaul does not normally return an item to like new condition.

k. Rebuild. Consists of those services/actions necessary for the restoration of unserviceable equipment to a like new condition in accordance with original manufacturing standards. Rebuild is the highest degree of materiel maintenance applied to Army equipment. The rebuild operation includes the act of returning to zero those age measurements (hours/miles, etc) considered in classifying Army equipments/components.

**B-3. EXPLANATION OF COLUMNS IN THE MAC, SECTION II**

a. Column 1, Group Number. Column 1 lists functional group code numbers, the purpose of which is to identify maintenance significant components, assemblies, subassemblies, and modules with the next higher assembly. End item group number shall be "00."

b. Column 2, Component/Assembly. Column 2 contains the names of components, assemblies, subassemblies, and modules for which maintenance is authorized.

c. Column 3, Maintenance Function. Column 3 lists the functions to be performed on the item listed in Column 2. (For detailed explanation of these functions, see paragraph B-2.)

---

<sup>2</sup>Services—inspect, test, service, adjust, align, calibrate, and/or replace.

<sup>3</sup>Fault locate/troubleshoot—The process of investigating and detecting the cause of equipment malfunctioning; the act of isolating a fault within a system or unit under test (UUT).

<sup>4</sup>Disassemble/assemble—encompasses the step-by-step taking apart (or breakdown) of a spare/functional group coded item to the level of its least component identified as maintenance significant (i.e., assigned an SMR code) for the category of maintenance under consideration.

<sup>5</sup>Actions—welding, grinding, riveting, straightening, facing, remachining, or resurfacing.

d. Column 4, Maintenance Category. Column 4 specifies, by the listing of a work time figure in the appropriate subcolumn(s), the category of maintenance authorized to perform the function listed in Column 3. This figure represents the active time required to perform that maintenance function at the indicated category of maintenance. If the number or complexity of the tasks within the listed maintenance function vary at different maintenance categories, appropriate work time figures will be shown for each category. The work time figure represents the average time required to restore an item (assembly, subassembly, component, module, end item, or system) to a serviceable condition under typical field operating conditions. This time includes preparation time (including any necessary disassembly/assembly time), troubleshooting/fault location time, and quality assurance/quality control time in addition to the time required to perform the specific tasks identified for the maintenance functions authorized in the maintenance allocation chart. The symbol designations for the various maintenance categories are as follows:

Field:

C .....Operator or crew

O .....Unit maintenance

F..... Direct support maintenance

Sustainment:

L.....Specialized Repair Activity (SRA)<sup>6</sup>

D ..... Depot maintenance

K .....Contractor Facility

e. Column 5, Tools and Equipment. Column 5 specifies, by code, those common tool sets (not individual tools) and special tools, TMDE, and support equipment required to perform the designated function.

f. Column 6, Remarks. This column shall, when applicable, contain a letter code, in alphabetic order, which shall be keyed to the remarks contained in Section IV.

**B-4. EXPLANATION OF COLUMNS IN TOOL AND TEST EQUIPMENT REQUIREMENTS, SECTION III.**

a. Column 1, Reference Code. The tool and test equipment reference code correlates with a code used in the MAC, Section II, Column 5.

b. Column 2, Maintenance Category. The lowest category of maintenance authorized to use the tool or test equipment.

c. Column 3, Nomenclature. Name or identification of the tool or test equipment.

---

<sup>6</sup>This maintenance category is not included in Section II, column (4) of the Maintenance Allocation Chart. To identify functions to this category of maintenance, enter a work time figure in the "H" column of Section II, column (4), and use an associated reference code in the Remarks column (6). Key the code to Section IV, Remarks, and explain the SRA complete repair application there. The explanatory remark(s) shall reference the specific Repair Parts and Special Tools List (RPSTL) TM that contains additional SRA criteria and the authorized spare/repair parts.

**B-4. EXPLANATION OF COLUMNS IN TOOL AND TEST EQUIPMENT REQUIREMENTS, SECTION III (cont)**

- d. Column 4, National Stock Number. The National stock number of the tool or test equipment.
- e. Column 5, Tool Number. The manufacturer's part number.

**B-5. EXPLANATION OF COLUMNS IN REMARKS, SECTION IV**

- a. Column 1, Reference Code. The code recorded in Column 6, Section II.
- b. Column 2, Remarks. This column lists information pertinent to the maintenance function being performed as indicated in the MAC, Section II.

**Section II. MAINTENANCE ALLOCATION CHART  
FOR M93 MUZZLE VELOCITY SYSTEM**

(1)  Group Number	(2)  Component/Assembly	(3)  Maintenance Function	(4) Maintenance Level					(5)  Tools and Equipment	(6)  Remarks
			Field			Sustainment			
			Unit		DS	GS	Depot		
			C	O	F	K	D		
00	MUZZLE VELOCITY SYSTEM, PALADIN 13002073	Inspect Test Replace		0.3 0.5 1.0	0.3 0.5	0.5			
01	TRANSCEIVER 13002074	Repair Inspect Test Replace Repair Overhaul		0.5 0.1 0.3	0.5 0.1 0.3 0.2		17.0	* * *	
0101	POWER SUPPLY MODULE AY6706291-0	Inspect Service Replace Repair				0.1 0.2 0.5 3.0		* * * *	
0102	DOPPLER AMPLIFIER AY6706566-0	Inspect Service Replace Repair						* * * *	

**Section II. MAINTENANCE ALLOCATION CHART  
FOR M93 MUZZLE VELOCITY SYSTEM (cont)**

(1)  Group Number	(2)  Component/Assembly	(3)  Maintenance Function	(4) Maintenance Level					(5)  Tools and Equipment	(6)  Remarks
			Field			Sustainment			
			Unit		DS	GS	Depot		
			C	O	F	K	D		
0103	EMI FILTER ASSEMBLY AY6707289-0	Inspect Test Replace Repair					*		
0104	MVP CIRCUIT CARD ASSEMBLY AY6707288-3 AY6707288-4 AY67010314	Inspect Test Replace Repair					*		
02	BRACKET, ANTENNA 1279003	Inspect Replace Repair		0.1 0.2	0.5				
03	0.75-M CABLE ASSEMBLY 12979004	Inspect Replace Repair		0.5 0.2	1.5		*		
04	5.0-M CABLE ASSEMBLY 12991852	Inspect Replace Repair		0.5	0.5 1.5 1.5		*		
05	1553 TERMINATION 12979006	Inspect Replace Repair		0.3 0.5	1.5			Figure 3-5	

\* TO BE DELIVERED WITH DEPOT REPAIR PROCEDURES.

**Section III. TOOL AND TEST EQUIPMENT REQUIREMENTS  
FOR M93 MUZZLE VELOCITY SYSTEM**

**Section IV. REMARKS FOR M93 MVS**

NOT APPLICABLE.



APPENDIX C

REPAIR PARTS AND SPECIAL TOOLS LIST

APPENDIX CONTENTS

Title	Page
Section I Introduction.....	C-1
Section II Repair Parts .....	C-9
Section III Special Support Equipment.....	C-60
Section IV Cross-Reference Indexes.....	C-67

SECTION I. INTRODUCTION

SECTION CONTENTS

Subject	Page
General .....	C-1
RPSTL Description.....	C-1
Explanation of Columns (Sections II and III).....	C-2
Explanation of Columns (Section IV) .....	C-6
How to Locate Repair Parts .....	C-8

**C.1 GENERAL.**

This Repair Parts and Special Tools List (RPSTL) lists and authorizes spares and repair parts; special tools; special test, measurement, and diagnostic equipment (TMDE); and other special support equipment required for performance of unit, direct support, and general support maintenance of the M93 MVS. It authorizes the requisitioning, issue, and disposition of spares, repair parts and special tools as indicated by the source, maintenance, and recoverability (SM&R) codes.

**C.2 RPSTL DESCRIPTION.**

This RPSTL is divided into the following sections:

**C.2.1 Section I - Introduction.** The Introduction describes the various sections that are contained in the RPSTL and explains the contents of various tables, codes, and indexes.

**C.2.2 Section II - Repair Parts List.** This is a list of spares and repair parts authorized by this RPSTL for use in the performance of maintenance. The list also includes parts, which must be removed for replacement of the authorized parts. Parts lists are composed of functional groups in ascending alphanumeric sequence, with the parts in each group listed in ascending figure and item number sequence. Bulk materials are listed by item name in FIG BULK at the end of the section. Repair parts kits or sets are listed separately in their own functional group within Section II. Repair parts for repairable special tools are also listed in this section.

**C.2.3 Section III - Special Tools List.** This is a list of special tools, special TMDE, and other special support equipment authorized by this RPSTL (as indicated by basis of issue (BOI) information in DESCRIPTION AND USABLE ON CODE (UOC) column) for the performance of maintenance.

**C.2.4 Section IV - Cross-reference Indexes.** This is a list, in national item identification number (NIIN) sequence, of all National stock numbered items appearing in the listing, followed by a list in alphanumeric sequence of all part numbers appearing in the listing. National stock numbers and part numbers are cross-referenced to each illustration figure and item number appearance. The figure and item number index lists figure and item numbers in alphanumeric sequence and cross-references NSN, CAGEC, and part numbers.

**C.3 EXPLANATION OF COLUMNS (SECTIONS II AND III).**

**C.3.1 Item No. (Column 1).** Indicates the number used to identify items called out in the illustration.

**C.3.2 SM&R Code (Column 2).** The source, maintenance, and recoverability (SM&R) code is a five-position code containing supply and requisitioning information, maintenance level authorization criteria, and disposition instructions, as shown in the following breakout:

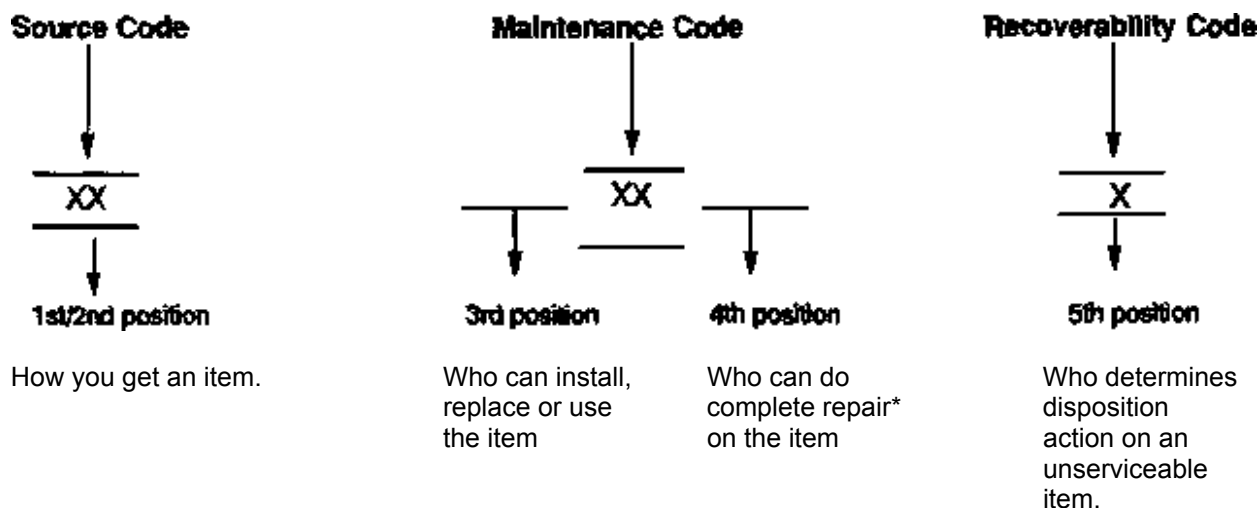

\*Complete Repair: Maintenance capacity, capability, and authority to perform all corrective maintenance tasks of the "Repair" function in a use/user environment in order to restore serviceability to a failed item.

**C.3.2.1 Source Code.** The source code tells you how to get an item needed for maintenance, repair, or overhaul of an end item or equipment item. Explanations of source codes follow:

Code	Explanation
PA PB PC** PD PE PF PG	Stocked items; use the applicable NSN to requisition items with these source codes. They are authorized to the level indicated by the code entered in the third position of the SM&R code.  **NOTE: Items coded PC are subject to deterioration.
KD KF KB	Items with these codes are not to be requested/requisitioned individually. They are part of a kit, which is authorized to the maintenance level, indicated in the third position of the SM&R code. The complete kit must be requisitioned and applied.
MO - (Made at unit AVUM Level)  MF - (Made at DS□ AVIM Level)  MH - (Made at GS Level) ML - (Made at SRA Level) SM&R MD - (Made at Depot Level)	Items with these codes are not to be requested/requisitioned individually. They must be made from bulk material which is identified by the part number in the DESCRIPTION AND USABLE ON CODE (UOC) column and listed in the Bulk Material group of the repair parts list in this RPSTL. If the item is authorized to you by the third position code of the code, but the source code indicates it is made at a higher level, order the item from the higher level of maintenance.

- AO - (Assembled by unit/AVUM Level)
- AF - (Assembled by DS/AVIM Level)
- AH - (Assembled by GS individually. Level)
- AL - (Assembled by SRA Level)
- AD - (Assembled by Depot Level)

Items with these codes are not to be requested or requisitioned

The parts that make up the assembled item must be requisitioned or fabricated and assembled at the level of maintenance indicated by the source code. if the third position code of the SM&R code authorizes you to replace the item, but the source code indicates the item is assembled at a higher level, order the item from the higher level of maintenance.

- XA - Do not requisition an "XA"-coded item. Order its next higher assembly. (Also, refer to the NOTE below.)
- XB - If an "XB" item is not available from salvage, order it. Using the CAGEC and part number given.
- XC - Installation drawing, diagram, instruction sheet, field service drawing, that is identified by manufacturer's part number.
- XD - Item is not stocked. Order an "XD"-coded item through normal supply channels using the CAGEC and part number given, if no NSN is available.

NOTE: Cannibalization or controlled exchange, when authorized, may be used as a source of supply for items with the above source codes, except for those source coded "XA" or those aircraft support items restricted by requirements of AR 750-1.

**C.3.2.2 Maintenance Code.** Maintenance codes tell you the level(s) of maintenance authorized to use and repair support items. The maintenance codes are entered in the third and fourth positions of the SM&R code as follows: The maintenance code entered in the third position tells you the lowest maintenance level authorized to remove, replace, and use an item. The maintenance code entered in the third position will indicate authorization to one of the following levels of maintenance.

<u>Code</u>	<u>Application/Explanation</u>
C	Crew or operator maintenance done within unit or aviation unit maintenance.
O	Unit or aviation unit level can remove, replace, and use the item.
F	Direct support or aviation intermediate level can remove, replace, and use the item.
H	General support level can remove, replace, and use the item.
L	Specialized repair activity (SRA) can remove, replace, and use the item.
D	Depot level can remove, replace, and use the item.

The maintenance code entered in the fourth position tells whether or not the item is to be repaired and identifies the lowest maintenance level with the capability to do complete repair (i.e., perform all authorized repair functions). (**NOTE:** Some limited repair may be done on the item at a lower level of maintenance, if authorized by the Maintenance Allocation Chart (MAC) and SM&R codes). This position will contain one of the following maintenance codes.

<u>Code</u>	<u>Application/Explanation</u>
O	Unit or aviation unit is the lowest level that can do complete repair of the item.
F	Direct support or aviation intermediate is the lowest level that can do complete repair of the item.
H	General support is the lowest level that can do complete repair of the item.
L	Specialized repair activity is the lowest level that can do complete repair of the item.
D	Depot is the lowest level that can do complete repair of the item.
Z	Nonrepairable. No repair is authorized.
B	No repair is authorized. No parts or special tools are authorized for the maintenance of the "B" coded item. However, the item may be reconditioned by adjusting, lubricating, etc., at the user level.

**C.3.2.3 Recoverability Code.** Recoverability are assigned to items to indicate the disposition action on unserviceable items. The recoverability code is entered in the fifth position of the SM&R code as follows:

<u>Recoverability Code</u>	<u>Application/Explanation</u>
Z	Nonrepairable item. When unserviceable, condemn and dispose of the item at the level of maintenance shown in third position of SM&R code.
O	Reparable item. When uneconomically repairable, condemn and dispose of the item at the unit or aviation unit level.
F	Reparable item. When uneconomically repairable, condemn and dispose of the item at the direct support or aviation intermediate level.
H	Reparable item. When uneconomically repairable, condemn and dispose of the item at the general support level.
D	Reparable item. When beyond lower level repair capability, return to depot. Condemnation and disposal of item not authorized below depot level.
L	Reparable item. Condemnation and disposal not authorized below specialized repair activity (SRA).
A	Item requires special handling or condemnation procedures because of specific reasons (e.g., precious metal content, high dollar value, critical material, or hazardous material). Refer to appropriate manuals and directives for specific instructions.

**C.3.3 CAGEC (Column 3).** The Contractor and Government Entity Code (CAGEC) is a five-digit numeric code which is used to identify the manufacturer, distributor, or government agency, etc., that supplies the item.

**C.3.4 Part Number (Column 4).** Indicates the primary number used by the manufacturer (individual, company, firm, corporation, or Government activity), which controls the design and characteristics of the item by means of its engineering drawings, specifications standards, and inspection requirements to identify an item or range of items.

**NOTE**

When you use an NSN to requisition an item, the item you receive may have a different part number from the part ordered.

**C.3.5 Description and Usable on Code (UOC) (Column 5).** This column includes the following information:

- a. The Federal item name and, when required, a minimum description to identify the item.
- b. The physical security classification of the item is indicated by the parenthetical entry which is a physical security classification abbreviation, e.g., Phy Sec C1 ©-Confidential, Phy Sec 01 (5)-Secret, Phy Sec C1 (T)-Top Secret.
- c. Items that are included in kits and sets are listed below the name of the kit or set.
- d. Spare/repair parts that make up an assembled item are listed immediately following the assembled item line entry.
- e. Part numbers for bulk materials are referenced in this column in the line item entry for the item to be manufactured/fabricated.
- f. When the item is not used with all serial numbers of the same model, the effective serial numbers are shown on the last line(s) of the description (before UOC).
- g. The usable on code, when applicable (see paragraph 5, Special Information).
- h. In the special tools list section, the basis of issue (BOI) appears as the last line(s) in the entry for each special tool, special TMDIE, and other special support equipment. When density of equipment supported exceeds density spread indicated in the basis of issue, the total authorization is increased proportionally.
- i. The statement "END OF FIGURE" appears just below the last item description in Column 5 for a given figure in both Section II and Section III.

**C.3.6 Qty (Column 6).** The QTY (quantity per figure column) indicates the quantity of the item used in the breakout shown on the illustration figure, which is prepared for a functional group, subfunctional group, or an assembly. A "V" appearing in this column in lieu of a quantity indicates that the quantity is variable and the quantity may vary from application to application.

**C.4 EXPLANATION OF COLUMNS (SECTION IV).**

**C.4.1 National Stock Number (NSN) Index.** NSN Index columns and entries are described in the paragraph below.

**C.4.1.1 Stock Number Column.** This column lists the NSN by national item identification number (NIIN) sequence. The NIIN consists of the last nine digits of the NSN. When using this column to locate an item, ignore the first four digits of the NSN. However, the complete NSN should be used when ordering items by stock number.

**C.4.1.2 FIG. Column.** This column lists the number of the figure where the item is identified/located. The figures are in numerical order in Section II and Section III.

**C.4.1.3 ITEM Column.** The item number identifies the item associated with the figure listed in the adjacent Fig. column. This item is also identified by the NSN listed on the same line.

**C.4.2 Part Number Index.** Part numbers in this index are listed by part number in ascending alphanumeric sequence (i.e., vertical arrangement of letter and number combination which places the first letter or digit of each group in order A thru Z, followed by the numbers 0 thru 9, and each following letter or digit in like order).

**C.4.2.1 CAGEC Column.** The Contractor and Government Entity Code (CAGEC) is a five-digit numeric code use to identify the manufacturer, distributor, or Government agency, etc., that supplies the item.

**C.4.2.2 PART NUMBER Column.** Indicates the primary number used by the manufacturer (individual, firm, corporation, or government activity), which controls the design and characteristics of the item by means of its engineering drawings, specifications standards, and inspection requirements to identify an item or range of items.

**C.4.2.3 STOCK NUMBER Column.** This column lists the NSN for the associated part number and manufacturer identified in the NUMBER and CAGEC columns to the left.

**C.4.2.4 FIG: Column.** This column lists the number of the figure where the item is identified/located in Sections II and III.

**C.4.2.5 ITEM Column.** The item number is that number assigned to the item as it appears in the figure referenced in the adjacent figure number column.

**C.4.3 Figure and Item Number Index.** Figure and Item Number Index columns and entries are described in the paragraph below.

**C.4.3.1 FIG. Column.** This column lists the number of the figure where the item is identified/located in Sections II and III.

**C.4.3.2 ITEM Column.** The item number is that number assigned to the item as it appears in the figure referenced in the adjacent figure number column.

**C.4.3.3 STOCK NUMBER Column.** This column lists the NSN for the item.

**C.4.3.4 CAGEC Column.** The Contractor and Government Entity Code (CAGEC) is a five-digit numeric code used to identify the manufacturer, distributor, or Government agency, etc., that supplies the item.

**C.4.3.5 PART NUMBER Column.** Indicates the primary number used by the manufacturer (individual, firm, corporation, or government activity), which controls the design and characteristics of the item by means of its engineering drawings, specifications standards, and inspection requirements to identify an item or range of items.

**C.5 HOW TO LOCATE REPAIR PARTS.**

**C.5.1 When national stock number or part number is not known:**

- a. Using the table of contents, determine the assembly group or subassembly group to which the item belongs. This is necessary since figures are prepared for assembly groups and subassembly groups, and listings are divided into the same groups.
- b. Find the figure covering the assembly group or subassembly group to which the item belongs.
- c. Identify the item on the figure and use the Figure and Item Number Index to find the NSN.

**C.5.2 When national stock number or part number is known:**

- a. Using the National Stock Number or the Part Number Index, find the pertinent National Stock Number or Part Number. The NSN index is in National Item Identification Number (NIIN) sequence. The part numbers in the Part Number index are listed in ascending alphanumeric sequence. Both indexes cross-reference you to the illustration/figure and item number of the item you are looking for.
- b. Turn to the figure and item number; verify that the item is the one you are looking for, then locate the item number in the repair parts list for the figure.



SECTION II. PARTS LIST

SECTION CONTENTS

Figure	Title	Page
C-1	M93 MVS Components, P/N 13002073 .....	C-10
C-2	Transceiver Assy, P/N 13002074 .....	C-13
C-3	Power Supply Module, P/N AY6707291-0.....	C-37
C-4	Power Supply CCA, P/N AY6707290-0.....	C-21
C-5	Doppler Amplifier CCA, P/N AY6706566-0 .....	C-34
C-6	EMI Filter Assembly, P/N AY6707289-1.....	C-38
C-7	MVP CCA, P/N AY67010314.....	C-40
C-8	Bracket Assembly, P/N 12979003.....	C-47
C-9	Power and Data Cable (0.75-Meter), P/N 12979004 .....	C-49
C-10	Power and Data Cable (5-Meter), P/N 12991852 .....	C-51



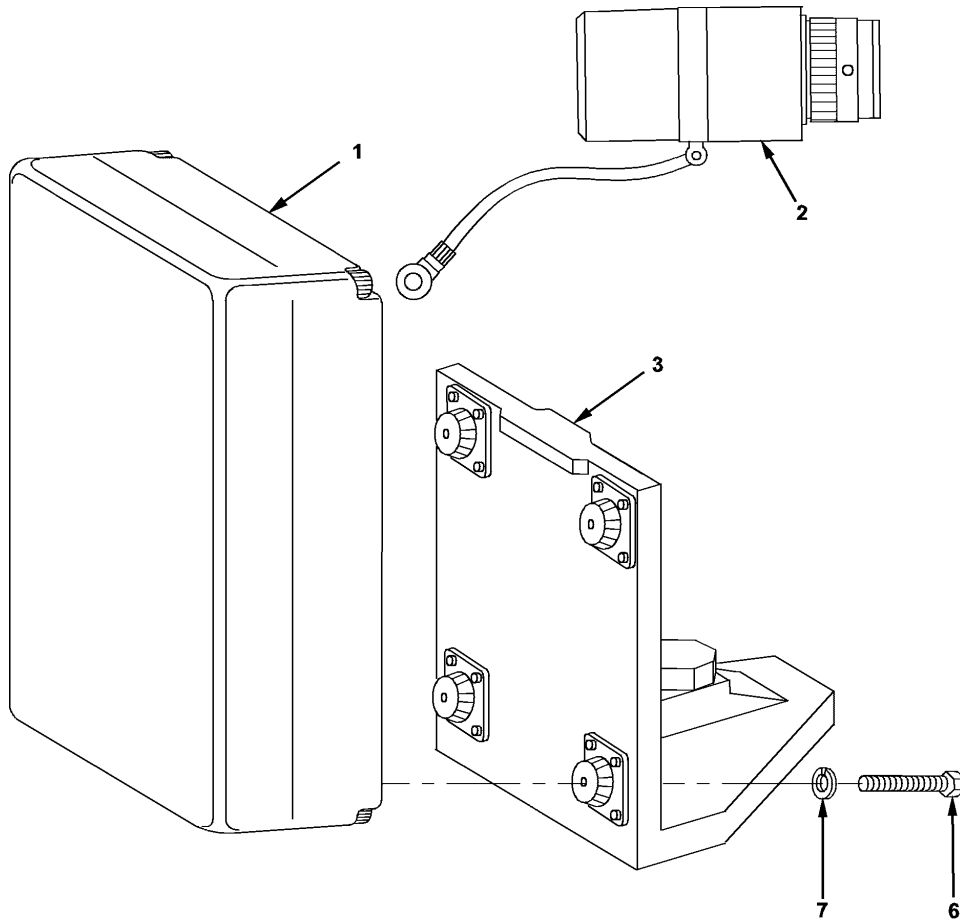

Figure C-1. M93 Muzzle Velocity System, P/N 13002073 (Sheet 1 of 2)

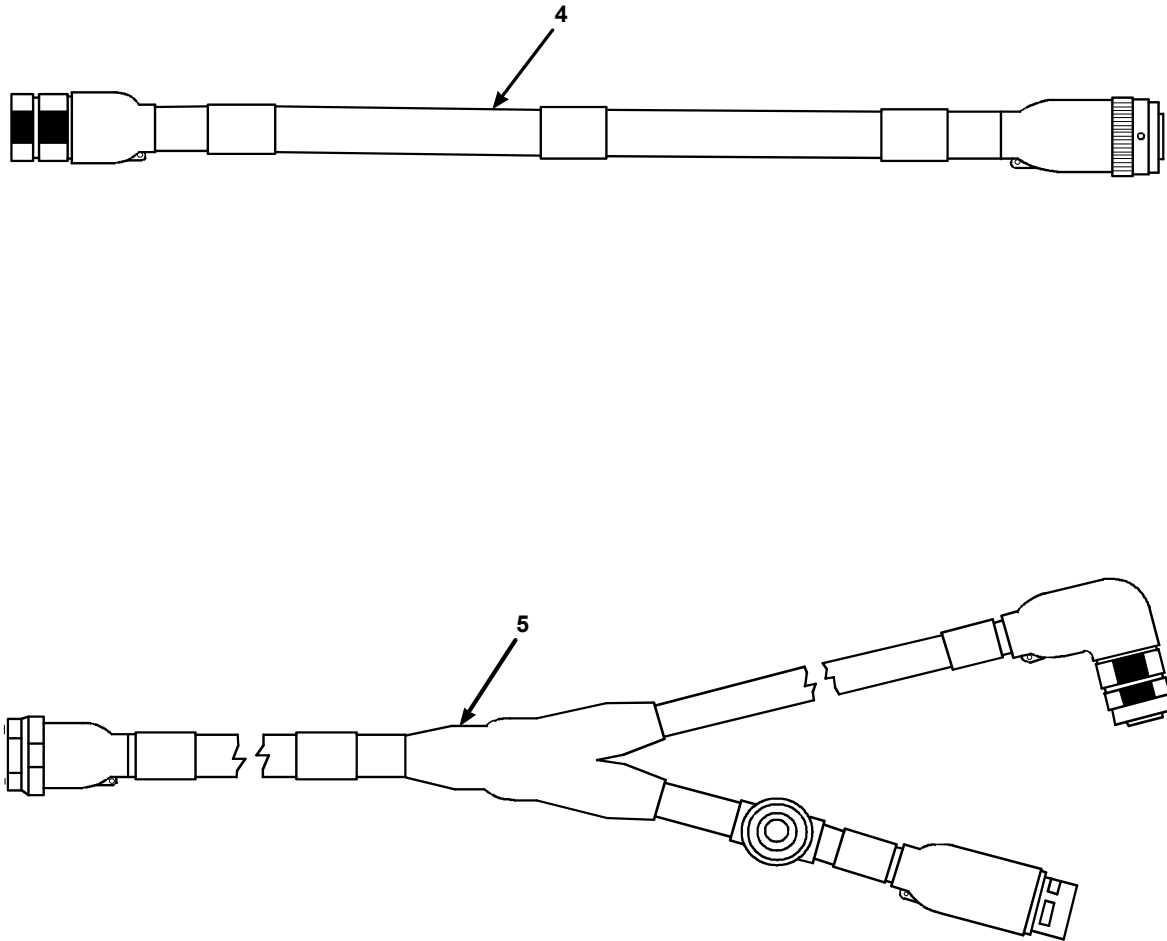

Figure C-1. M93 Muzzle Velocity System, P/N 13002073 (Sheet 2 of 2)

SECTION II			TM9-1290-365-24&P,C01		(6)	(7)
(1)	(2)	(3)	(4)	(5)		
ITEM	SMR			PART		
NO	CODE	NSN	CAGEC	NUMBER	DESCRIPTION AND USABLE ON CODES(UOC)	QTY
FIG. C-1 M93 MUZZLE VELOCITY SYSTEM, P/N 13002073						
1	PAODD	5895014177101	19200	13002074	RECEIVER-TRANSMITTE FOR COMPONENT	1
					PARTS SEE FIG C-2.....	
2	PAOZZ	5935014354414	19200	12979006	CONNECTOR,PLUG,ELEC.....	1
3	PAOOO	5340014405938	19200	12979003	BRACKET ANGLE FOR COMPONENT PARTS	1
					SEE FIG C-8.....	
4	PAOFF	6150014461595	19200	12979004	CABLE ASSEMBLY,SPEC FOR COMPONENT	1
					PARTS SEE FIG C-9.....	
5	PAODD		19200	12991852	CABLEASSEMBLY,SPEC.....	1
6	PAOZA	5305121897984	D8286	DIN912-M6X40-12.	SCREW,CAP, SOCKET HE.....	4
				9-B2P		
7	PAOZZ	5310009338121	96906	MS35338-139	WASHER, LOCK.....	4

END OF FIGURE

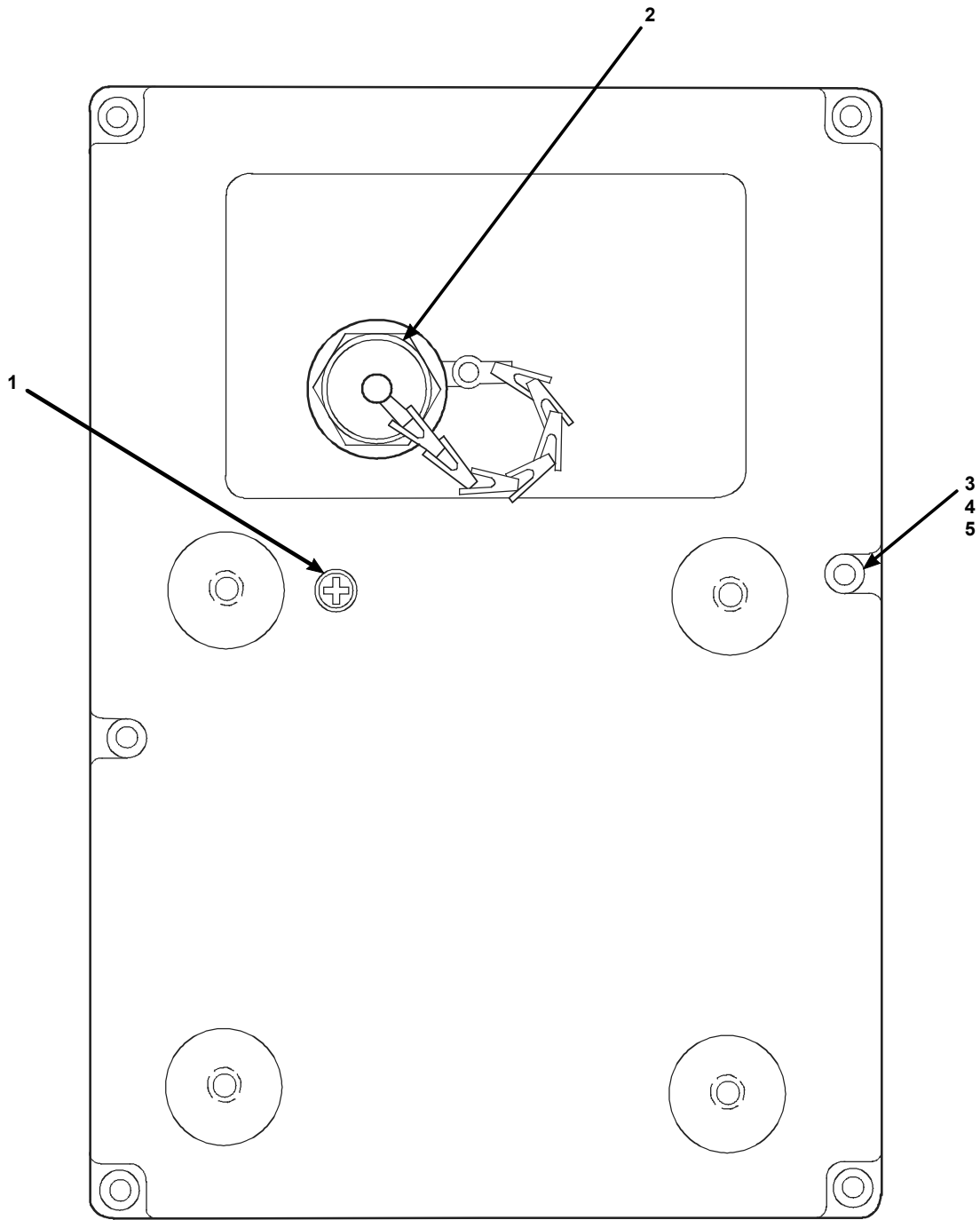

Figure C-2. Transceiver Assy, P/N 13002074 (Sheet 1 of 3)

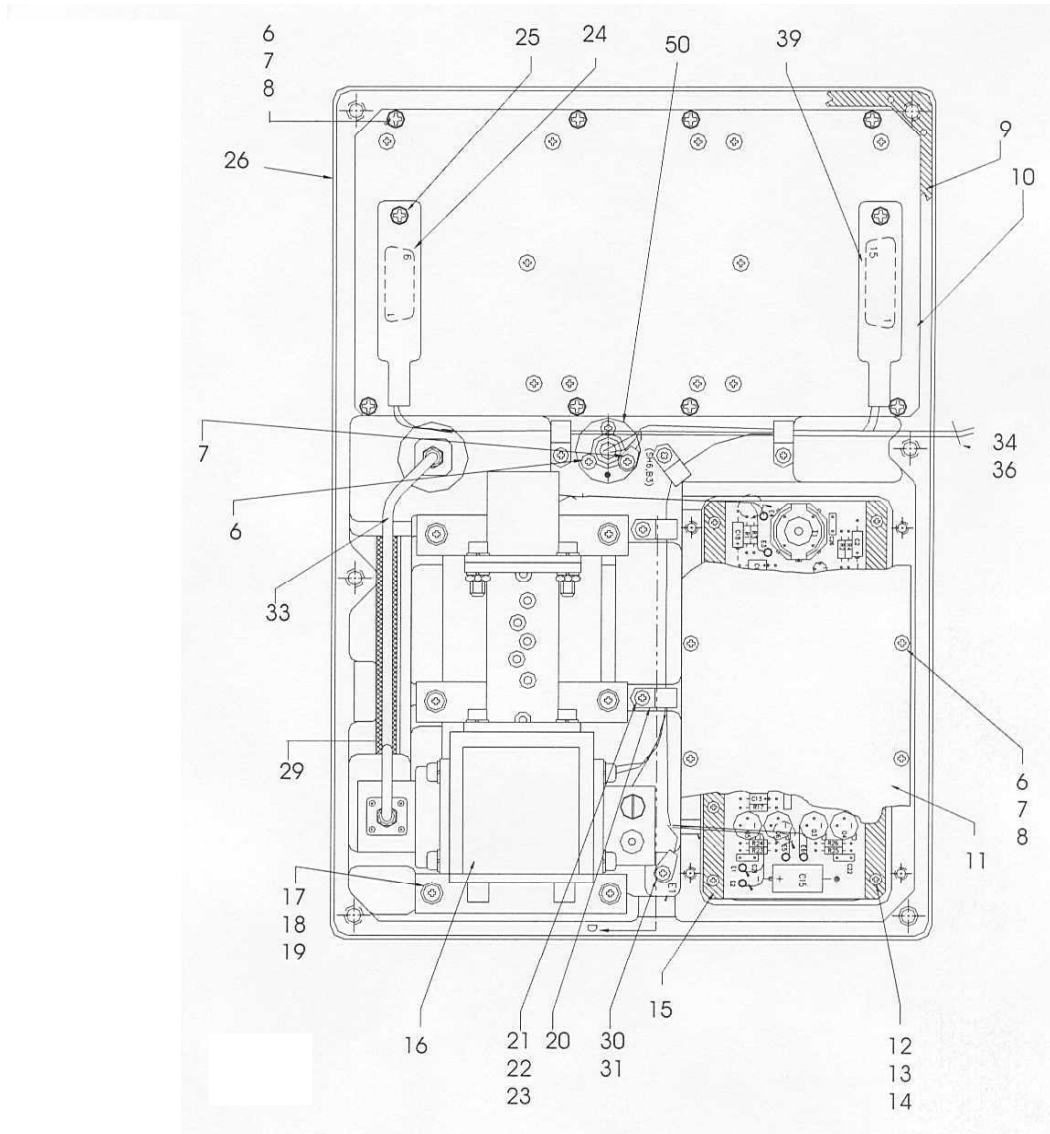

Figure C-2. Transceiver, P/N 13002074 (Sheet 2 of 3)

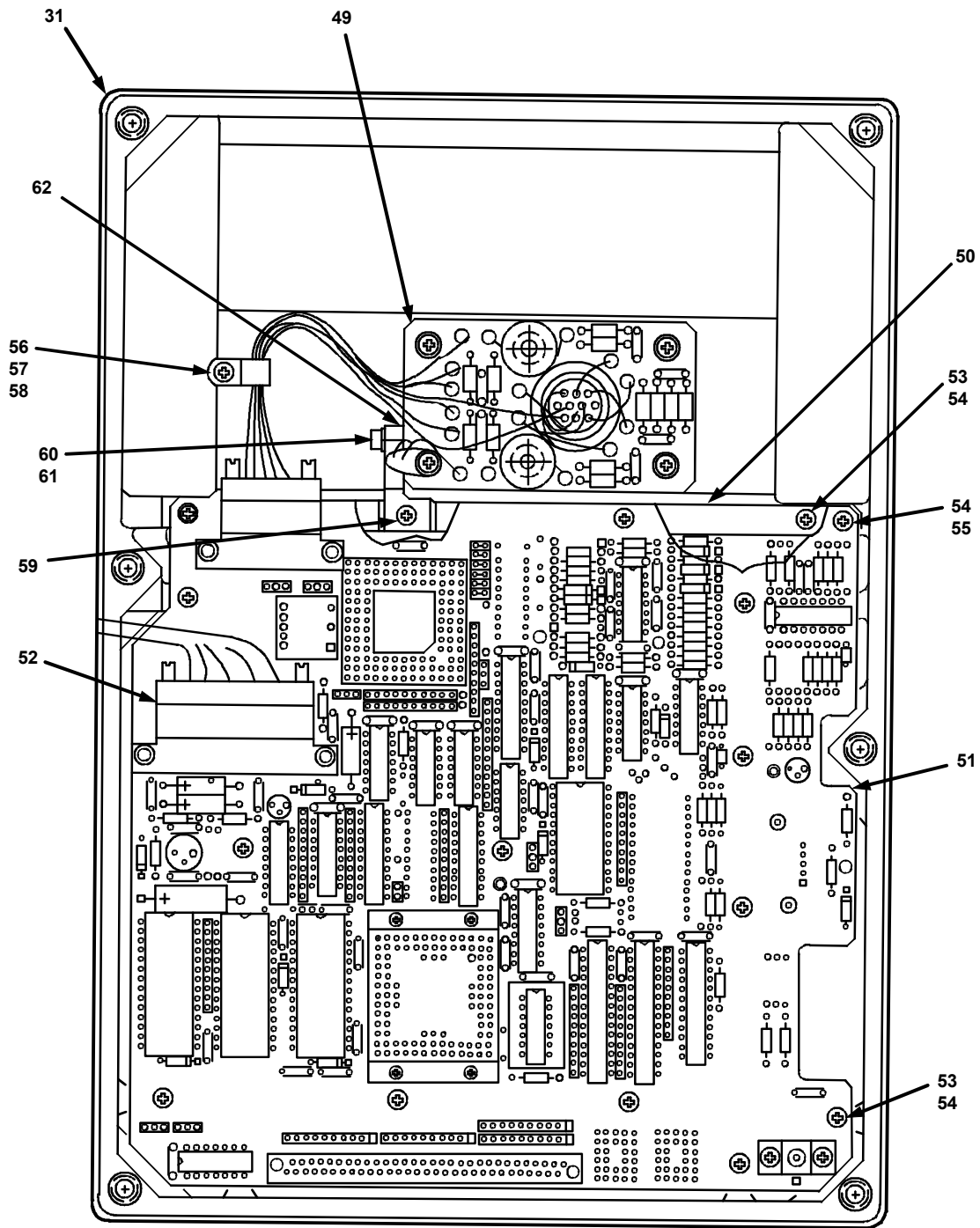

Figure C-2. Transceiver, P/N 13002074 (Sheet 3 of 3)



SECTION II TM9-1290-365-24&P,C01  
 (1) (2) (3) (4) (5) (6) (7)  
 ITEM SMR PART  
 NO CODE NSN CAGEC NUMBER DESCRIPTION AND USABLE ON CODES(UOC) QTY

FIG. C-2 TRANSCEIVER ASSY,  
 P/N 13002074

1	PADZZ	5305008552989	96906	MS3212-31	SCREW,MACHINE.....	1
2	PADZZ	5935012798630	81349	D38999/33W13N	COVER,ELECTRICAL CO.....	1
3	MDDZZ		S7040	MP6706562-0	SCREW,CAPTIVE.....	6
4	PADZZ	5310009338120	96906	MS35338-138	WASHER,LOCK.....	6
5	PADZZ	5310007819483	80205	NAS620C10L	WASHER,FLAT.....	6
5A	PGDZZ	9905014461594	19200	12979007	PLATE,IDENTIFICATIO.....	1
6	PADZZ	5305000545649	96906	MS51957-15	SCREW,MACHINE.....	17
7	PADZZ	5310009338118	96906	MS35338-135	WASHER,LOCK.....	21
8	PADZZ	5310000570573	80205	NAS620C4	WASHER,FLAT.....	34
9	PADZZ	5330014426611	S7040	MP6706570-0	GASKET ANTENNA.....	1
10	PADDD	6130014354417	S7040	AY6707291-0	POWER SUPPLY FOR COMPONENT PARTS SEE FIG. C-3.....	1
11	XADZZ		S7040	MP6706569-0	COVER,DOPPLER.....	1
12	PADZZ	5305000545637	96906	MS51957-3	SCREW,MACHINE.....	13
13	PADZZ	5310009282690	96906	MS35338-134	WASHER,LOCK.....	12
14	PADZZ	5310000434708	80205	NAS620C2	WASHER,FLAT.....	12
15	PADDD	5998014353129	S7040	AY6706566-0	CIRCUIT CARD ASSEMB FOR COMPONENT PARTS SEE FIG. C-5.....	1
16	PADDD	5840014464156	S7040	AY6706557-0	TRANSCEIVER,RADAR.....	1
17	PADZZ	5305000546670	96906	MS51957-45	.SCREW,MACHINE.....	6
18	PADZZ	5310009338119	96906	MS35338-137	WASHER,LOCK.....	6
19	PADZZ	5310006853744	88041	AN960C8	WASHER,FLAT.....	6
20	PADZZ	5340011602304	96906	MS21919WCG2	CLAMP,LOOP.....	1
21	PADZZ	5305000545647	96906	MS51957-13	SCREW,MACHINE.....	4
22	PADZZ	5310011416672	88044	AN960C4	WASHER,FLAT.....	5
23	XDDZZ		S7040	WA6706563-0	CABLE,SPECIAL PURPO.....	1
24	PADZA	5935004905219	81349	M24308/2-1	CONNECTOR,RECEPTACL.....	1
25	PADZZ	5935011793497	81349	M24308/25-9	RETAINER,ELECTRICAL.....	4
26	XADZZ		S7040	EA6706148-0	MICROSTRIP ANTENNA.....	1
27	XADZZ		S7040	AM6707834-0	COVER.....	1
28	XBDZZ		S7040	NP6707412-0	NAMEPLATE.....	1
29	XADZZ		S7040	MP6708090-0	RUBBER.....	2
30	PADZZ	5305000545646	96906	MS51957-12	SCREW,MACHINE.....	1
31	PADZZ	5940006822477	96906	MS77068-1	TERMINAL,LUG.....	1
32	PADZZ	5340007828737	80205	NAS1397P4N	CLAMP,LOOP.....	5
33	PADZZ	6145011356836	81349	M27500-22SB2T23	CABLE,SPECIAL PURPO.....	V
34	PADZA	6145009394955	81349	M22759/11-20-0	WIRE,ELECTRICAL.....	V
35	PADZZ	5940011357077	81349	M83519/1-3	SPLICE,CONDUCTOR.....	2
36	PADZA	6145009489479	81349	M22759/11-24-9	WIRE,ELECTRICAL.....	V
37	PADZZ	5940011362540	81349	M83519/1-2	SPLICE,CONDUCTOR.....	2
38	PADZZ	5970000823942	81349	M23053/5-105-9	INSULATION SLEEVING.....	1
39	PADZA	5935004903743	81349	M24308/4-2	CONNECTOR,RECEPTACL.....	1
40	PADDZ	5915014489399	S7040	AY6707289-1	FILTER,RADIO FREQUE FOR COMPONENT PARTS SEE FIG. C-6.....	1
41	PADZZ	5365014485081	S7040	MP6707852-0	SPACER,SPECIAL SHAP.....	1
42	PADDD	5998014353132	S7040	AY67010314	CIRCUIT CARD ASSEMB FOR COMPONENT PARTS SEE FIG. C-7.....	1
42	PADDD		S7040	AY67010314	CIRCUIT CARD ASSEMB FOR COMPONENT PARTS SEE FIG. C-7.....	1

SECTION II		TM9-1290-365-24&P					
(1)	(2)	(3)	(4)	(5)	(6)	(7)	
ITEM	SMR			PART			
NO	CODE	NSN	CAGEC	NUMBER	DESCRIPTION AND USABLE ON CODES(UOC)	QTY	
43	PADZZ	5935014472752	81349	M55302/66L26H	CONNECTOR, RECEPTACL.....	1	
44	PADZZ	5305000545648	96906	MS51957-14	SCREW, MACHINE.....	17	
45	PADZZ	5305000545652	96906	MS51957-18	SCREW, MACHINE.....	3	
46	PADZZ	5310005956761	96906	MS15795-802	WASHER, FLAT.....	1	
47	PADZZ	5305009939189	96906	MS24693-C2	SCREW, MACHINE.....	1	
48	PADZZ	5305009590379	96906	MS16995-10	SCREW, CAP, SOCKET HE.....	1	
49	PADZZ	5340014478669	S7040	MP6708199-0	BRACKET, ANGLE.....	1	
50	PADZZ	1290014503467	S7040	AY67010553	SIMUALTOR, INTEGRATE.....	1	

END OF FIGURE



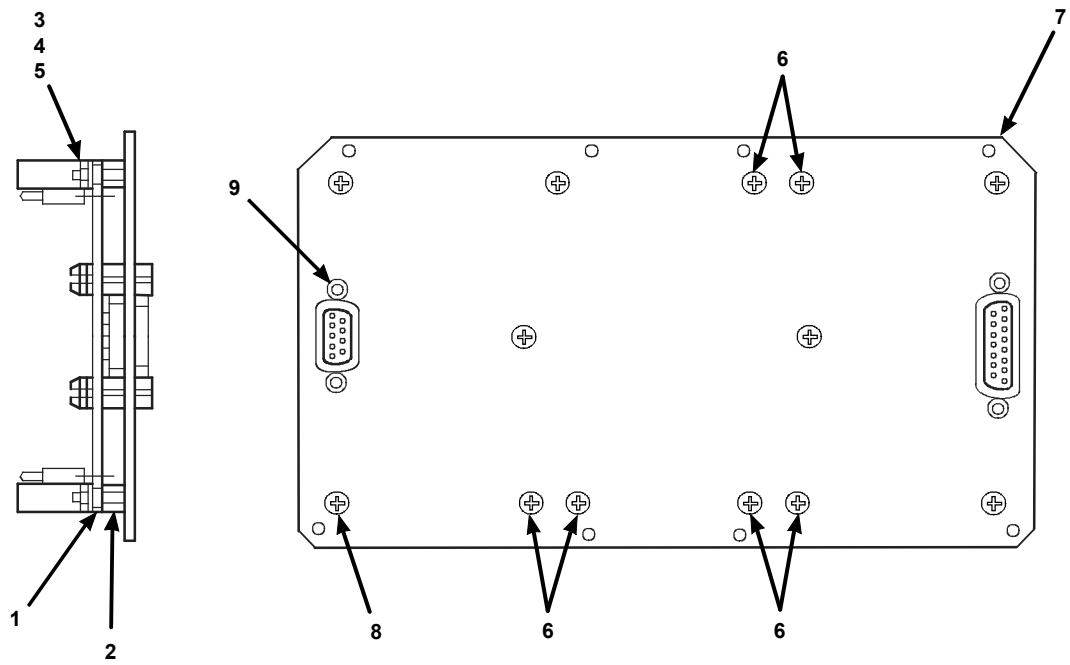

Figure C-3. Power Supply Module, P/N AY6707291-0

SECTION II			TM9-1290-365-24&P		(6)	(7)
(1)	(2)	(3)	(4)	(5)		
ITEM	SMR			PART		
NO	CODE	NSN	CAGEC	NUMBER	DESCRIPTION AND USABLE ON CODES (UOC)	QTY
FIG. C-3 POWER SUPPLY MODULE, P/N AY6707291-0						
1	PADDD	5998014359715	S7040	AY6707290-0	CIRCUIT CARD ASSEMB FOR COMPONENT	1
					PARTS SEE FIG. C-4.....	
2	PADZZ	5365014428174	S7040	MP6706605-0	SPACER, SLEEVE.....	7
3	PADZZ	5310007239676	80205	NAS620C4L	WASHER, FLAT.....	7
4	PADZZ	5310009338118	96906	MS35338-135	WASHER, LOCK.....	7
5	PADZZ	5310002083786	80205	NAS671C4	NUT, PLAIN, HEXAGON.....	7
6	PADZZ	5305002256400	96906	MS24693-C3	SCREW, MACHINE.....	6
7	XADZZ		S7040	MP6707423-0	COVER MECHANISM.....	1
8	PADZZ	5305007808454	96906	MS24693-C7	SCREW, MACHINE.....	7
9	PADZZ	5365014435130	S7040	MP6706607-0	SPACER, SLEEVE.....	4

END OF FIGURE

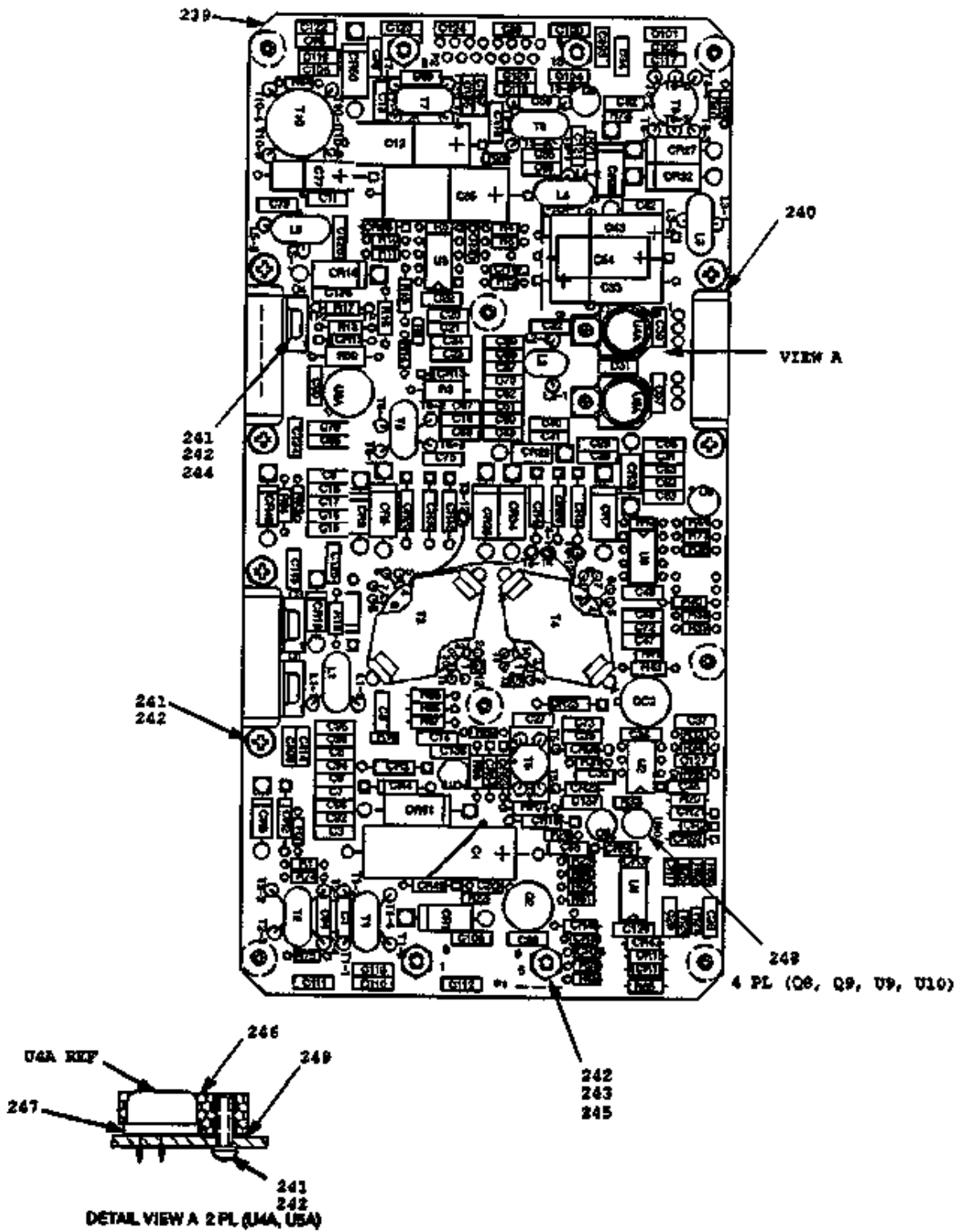

Figure C-4. Power Supply CCA P/N AY6707290-0 (Sheet 1 of 5)

LEGEND

REF DES	ITEM NO.	REF DES	ITEM NO.	REF DES	ITEM NO.
C1	1	C32	17	C112	10
C2	1	C33	11	C113	10
C3	1	C34	17	C114	10
C4	15	C36	12	C115	10
C5	17	C37	13	C116	10
C6	17	C38	14	C117	10
C7	17	C39	17	C118	10
C8	1	C43	2	C119	10
C9	17	C46	16	C120	10
C10	17	C47	1	C121	10
C11	17	C48	1	C122	10
C12	2	C54	18	C123	10
C13	17	C65	1	C124	10
C14	1	C69	1	C125	3
C15	17	C77	19	C126	4
C16	17	C85	20	C127	13
C17	17	C96	10	C136	5
C18	17	C98	10	C138	6
C19	1	C99	10	CR1	21
C20	17	C100	10	CR2	28
C21	7	C101	10	CR3	33
C22	8	C102	10	CR4	35
C23	9	C103	10	CR5	35
C24	10	C104	10	CR6	35
C25	1	C105	10	CR7	40
C26	17	C106	10	CR8	40
C27	17	C107	10	CR9	41
C28	17	C108	10	CR10	22
C29	17	C109	10	CR12	23
C30	17	C110	10	CR13	25
C31	17	C111	10	CR14	24

Figure C-4. Power Supply CCA, P/N AY6707290-0 (Sheet 2 of 5)

LEGEND

REF DES	ITEM NO.	REF DES	ITEM NO.	REF DES	ITEM NO.
CR15	26	CR52	22	R15	56
CR16	35	CR53	22	R16	57
CR17	22	CR54	22	R16	58
CR18	27	CR55	27	R16	59
CR19	33	CR56	37	R16	60
CR20	22	L1	42	R16	61
CR21	29	L2	42	R16	62
CR22	35	L3	42	R16	63
CR23	35	L4	42	R16	64
CR24	30	L5	42	R16	65
CR25	35	OC.2	43	R16	66
CR26	31	P1	44	R16	67
CR27	32	P2	45	R16	68
CR25	35	Q1	46	R16	69
CR29	30	Q2	47	R16	70
CR30	35	Q3	46	R16	71
CR31	31	Q4	46	R16	72
CR32	32	Q8	48	R16	73
CR34	40	Q9	49	R16	74
CR35	40	Q10	48	R16	75
CR36	34	R1	50	R17	76
CR37	22	R2	197	R17	77
CR38	22	R4	209	R17	78
CR39	22	R5	214	R17	79
CR44	30	R6	215	R17	80
CR45	35	R8	214	R17	81
CR46	36	R9	224	R17	82
CR47	26	R10	51	R17	83
CR48	37	R11	52	R17	84
CR49	37	R12	53	R17	85
CR50	38	R13	54	R17	86
CR51	39	R14	51	R17	87

Figure C-4. Power Supply CCA, P/N AY6707290-0 (Sheet 3 of 5)



LEGEND

REF DES	ITEM NO.	REF DES	ITEM NO.	REF DES	ITEM NO.
R17	88	R17	120	R17	152
R17	89	R17	121	R17	153
R17	90	R17	122	R17	154
R17	91	R17	123	R17	155
R17	92	R17	124	R17	156
R17	93	R17	125	R17	157
R17	94	R17	126	R17	158
R17	95	R17	127	R17	159
R17	96	R17	128	R17	160
R17	97	R17	129	R17	161
R17	98	R17	130	R17	162
R17	99	R17	131	R17	163
R17	100	R17	132	R17	164
R17	101	R17	133	R17	165
R17	102	R17	134	R17	166
R17	103	R17	135	R17	167
R17	104	R17	136	R17	168
R17	105	R17	137	R17	169
R17	106	R17	138	R17	170
R17	107	R17	139	R17	171
R17	108	R17	140	R17	172
R17	108	R17	141	R17	173
R17	110	R17	142	R17	174
R17	111	R17	143	R17	175
R17	112	R17	144	R17	176
R17	113	R17	145	R17	177
R17	114	R17	146	R17	178
R17	115	R17	147	R17	179
R17	116	R17	148	R17	180
R17	117	R17	149	R17	181
R17	118	R17	150	R17	182
R17	119	R17	151	R17	183

Figure C-4. Power Supply CCA, P/N AY6707290-0 (Sheet 4 of 5)

LEGEND

REF DES	ITEM NO.	REF DES	ITEM NO.	REF DES	ITEM NO.
R17	184	R33	206	R88	222
R17	185	R34	214	R89	223
R17	186	R36	214	R90	225
R17	187	R38	207	R91	51
R17	188	R39	208	R92	222
R17	189	R40	210	R138	55
R17	190	R41	202	T1	226
R17	191	R42	211	T2	227
R17	192	R43	212	T3	228
R17	193	R44	213	T4	229
R17	194	R45	202	T5	230
R17	195	R64	216	T6	231
R18	215	R65	217	T7	226
R19	196	R66	218	T8	232
R20	198	R67	199	T9	226
R21	52	R68	219	T10	226
R22	199	R69	51	U1	233
R23	52	R70	220	U2	234
R24	200	R71	197	U3	233
R25	201	R72	197	U4A	235
R26	202	R73	214	U5A	236
R27	202	R74	221	U6	237
R28	203	R75	221	U8A	235
R29	204	R84	202	U9	238
R30	205	R85	216	U10	238
R31	202	R86	216		
R32	197	R87	216		

Figure C-4. Power Supply CCA, P/N AY6707290-0 (Sheet 5 of 5)

SECTION II		TM9-1290-365-24&P				
(1)	(2)	(3)	(4)	(5)	(6)	(7)
ITEM	SMR			PART		
NO	CODE	NSN	CAGEC	NUMBER	DESCRIPTION AND USABLE ON CODES (UOC)	QTY
FIG. C-4 POWER SUPPLY CCA, P/N 6707290-0						
1	PADZZ	5910001135499	81349	M39014/02-1350	CAPACITOR, FIXED, CER.....	16
2	PADZZ	5910011262071	81349	M39006/22-0531	CAPACITOR, FIXED, ELE.....	2
3	PADZZ	5910012076979	81349	M39014/22-0973	CAPACITOR, FIXED, CER.....	1
4	PADZZ	5910001135465	81349	M39014/02-1360	CAPACITOR, FIXED, CER.....	1
5	PADZZ	5910001430501	81349	M39014/02-1332	CAPACITOR, FIXED, CER.....	1
6	PADZZ	5910013334896	81349	M39014/02-1355V	CAPACITOR, FIXED, CER.....	1
7	PADZZ	5910001135284	81349	M39014/02-1358	CAPACITOR, FIXED, CER.....	1
8	PADZZ	5910011718693	81349	M39014/22-1094	CAPACITOR, FIXED, CER.....	1
9	PADZZ	5910011415549	81349	M39014/22-1058	CAPACITOR, FIXED, CER.....	1
10	PADZZ	5910011718692	81349	M39014/22-1076	CAPACITOR, FIXED, CER.....	29
11	PADZZ	5910012341523	81349	M39006/22-0528	CAPACITOR, FIXED, ELE.....	1
12	XDDZZ		81349	M39014/22-1060	CAPACITOR, FIXED, CER.....	1
13	PADZZ	5910011718690	81349	M39014/22-0986	CAPACITOR, FIXED, CER.....	2
14	PADZZ	5910001135286	81349	M39014/02-1356	CAPACITOR, FIXED, CER.....	1
15	PADZZ	5910011194313	81349	M39006/22-0660	CAPACITOR, FIXED, ELE.....	1
16	PADZZ	5910001710018	81349	M39014/02-1349	CAPACITOR, FIXED, CER.....	1
17	PADZZ	5910000108721	81349	M39014/02-1419	CAPACITOR, FIXED, CER.....	57
18	PADZZ	5910012710897	81349	M39003/03-3025	CAPACITOR, FIXED, ELE.....	1
19	PADZZ	5910011194310	81349	M39006/22-0545	CAPACITOR, FIXED, ELE.....	1
20	PADZZ	5910013318610	81349	M39006/25-0222	CAPACITOR, FIXED, ELE.....	1
21	PADZZ	5961010552232	81349	JANTX1N5420	SEMICONDUCTOR DEVIC.....	1
22	PADZZ	5961005844527	81349	JANTX1N4148-1	SEMICONDUCTOR DEVIC.....	9
23	PADZZ	5961010485636	81349	JANTX1N4573A	SEMICONDUCTOR DEVIC.....	1
24	PADZZ	5961010170992	81349	JANTX1N4106	SEMICONDUCTOR DEVIC.....	1
25	PADZZ	5961002728333	81349	JANTX1N4961	SEMICONDUCTOR DEVIC.....	1
26	PADZZ	5961010681652	81349	JANTX1N5311	SEMICONDUCTOR DEVIC.....	2
27	PADZZ	5961011050607	81349	JANTX1N750A-1	SEMICONDUCTOR DEVIC.....	2
28	PADZZ	5961010096320	81349	JANTX1N4478	SEMICONDUCTOR DEVIC.....	1
30	PADZZ	5961013817429	81349	JANTX1N6621	SEMICONDUCTOR DEVIC.....	3
31	PADZZ	5961010879430	81349	JANTX1N4474	SEMICONDUCTOR DEVIC.....	2
32	PADZZ	5961004586778	81349	JANTX1N4964	SEMICONDUCTOR DEVIC.....	2
33	PADZZ	5961003243078	81349	JANTX1N4469	SEMICONDUCTOR DEVIC.....	2
34	PADZZ	5961012390829	81349	JANTX1N5969	SEMICONDUCTOR DEVIC.....	1
35	PADZZ	5961010374712	81349	JANTX1N5806	SEMICONDUCTOR DEVIC.....	10
36	PADZZ	5961010963192	81349	JANTX1N4475	SEMICONDUCTOR DEVIC.....	1
37	PADZZ	5961010644876	81349	JANTX1N966B-1	SEMICONDUCTOR DEVIC.....	3
38	PADZZ	5961004997249	81349	JANTX1N4965	SEMICONDUCTOR DEVIC.....	1
39	XDDZZ		81349	JANTX1N6064A	SEMICONDUCTOR DEVIC.....	1
40	PADZZ	5961010586633	81349	JANTX1N5811	SEMICONDUCTOR DEVIC.....	4
41	PADZZ	5961007285309	81349	JANTX1N4471	SEMICONDUCTOR DEVIC.....	1
42	PADZZ	5950014478128	S7040	TM6707404-0	COIL, ELECTRICAL.....	5
43	PADZZ	5980011590947	81349	JANTX4N49	COUPLER, OPTOELECTRO.....	1
44	PADZZ	5935010715291	81349	M24308/24-7	CONNECTOR, RECEPTACL.....	1
45	PADZA	5935013218932	81349	M24308/23-8F	CONNECTOR, RECEPTACL.....	1
46	PADZZ	5961014464255	59993	IRFY140	TRANSISTOR.....	3
47	PADZZ	5961011969452	81349	JANTX2N6796	TRANSISTOR.....	1
48	PADZA	5961008583826	81349	JANTX2N2222A	TRANSISTOR.....	2
49	PADZZ	5961010194947	81349	JANTXV2N2907A	TRANSISTOR.....	1
50	PADZZ	5905011763870	81349	RLR05C4702GS	RESISTOR, FIXED, FILM.....	1

SECTION II		TM9-1290-365-24&P					
(1)	(2)	(3)	(4)	(5)	(6)	(7)	
ITEM	SMR			PART			
NO	CODE	NSN	CAGEC	NUMBER	DESCRIPTION AND USABLE ON CODES (UOC)	QTY	
51	PADZZ	5905011700380	81349	RLR05C1002FS	RESISTOR, FIXED, FILM.....	4	
52	XDDZZ		81349	RLR05C1004FR	RESISTOR, FIXED, FILM.....	3	
53	PADZZ	5905011757856	81349	RLR05C4991FS	RESISTOR, FIXED, FILM.....	1	
54	PADZZ	5905011709062	81349	RLR05C3651FS	RESISTOR, FIXED, FILM.....	1	
55	PADZZ	5910001135536	81349	M39014/02-1355	CAPACITOR, FIXED, CER.....	1	
56	PADZZ	5905004445479	81349	RNC50H1002FS	RESISTOR, FIXED, FILM.....	1	
57	PADZZ	5905011867774	81349	RLR05C2491FS	RESISTOR, FIXED, FILM.....	1	
58	PADZZ		81349	RNC50J2002FR	RESISTOR, FIXED, FILM.....	1	
59	PADZZ	5905002851204	81349	RNC50J2052FS	RESISTOR, FIXED, FILM.....	1	
60	PADZA	5905010238999	81349	RNC50J2872FS	RESISTOR, FIXED, FILM.....	1	
61	PADZA	5905010801512	81349	RNC50J2802FS	RESISTOR, FIXED, FILM.....	1	
62	PADZA	5905010238084	81349	RNC50J2742FS	RESISTOR, FIXED, FILM.....	1	
63	PADZA	5905010801503	81349	RNC50J2672FS	RESISTOR, FIXED, FILM.....	1	
64	PADZA	5905001828104	81349	RNC50J2612FS	RESISTOR, FIXED, FILM.....	1	
65	PADZZ	5905002625271	81349	RNC50J3012FS	RESISTOR, FIXED, FILM.....	1	
66	PADZZ	5905003357858	81349	RNC50J2372FS	RESISTOR, FIXED, FILM.....	1	
67	PADZZ	5905010674888	81349	RNC50J2492FS	RESISTOR, FIXED, FILM.....	1	
68	PADZA	5905010801502	81349	RNC50J2102FS	RESISTOR, FIXED, FILM.....	1	
69	PADZZ	5905010123748	81349	RNC50J2152FS	RESISTOR, FIXED, FILM.....	1	
70	PADZA	5905001828103	81349	RNC50J2432FS	RESISTOR, FIXED, FILM.....	1	
71	PADZZ	5905002850620	81349	RNC50J2212FS	RESISTOR, FIXED, FILM.....	1	
72	PADZZ	5905011276301	81349	RNC50J2262FS	RESISTOR, FIXED, FILM.....	1	
73	PADZA	5905001828105	81349	RNC50J2942FS	RESISTOR, FIXED, FILM.....	1	
74	XDDZZ		81349	RNC50J2322FS	RESISTOR, FIXED, FILM.....	1	
75	XDHZZ		81349	RLR05C1620FS	RESISTOR, FIXED, FILM.....	1	
76	PADZZ	5905001121308	81349	RNC50J8251FS	RESISTOR, FIXED, FILM.....	1	
77	PADZA	5905010368619	81349	RNC50J2261FS	RESISTOR, FIXED, FILM.....	1	
78	PADZZ	5905011276299	81349	RNC50J1401FS	RESISTOR, FIXED, FILM.....	1	
79	PADZZ	5905001859131	81349	RNC50J1402FS	RESISTOR, FIXED, FILM.....	1	
80	PADZA	5905005816474	81349	RNC50J1432FS	RESISTOR, FIXED, FILM.....	1	
81	PADZZ	5905005789983	81349	RNC50J1101FS	RESISTOR, FIXED, FILM.....	1	
82	XDDZZ		81349	RNC50J1431FS	RESISTOR, FIXED, FILM.....	1	
83	PADZA	5905005347164	81349	RNC50J2321FS	RESISTOR, FIXED, FILM.....	1	
84	PADZZ	5905011330534	81349	RNC50J1471FS	RESISTOR, FIXED, FILM.....	1	
85	PADZZ	5905001890731	81349	RNC50J1961FS	RESISTOR, FIXED, FILM.....	1	
86	PADZA	5905005490919	81349	RNC50J1962FS	RESISTOR, FIXED, FILM.....	1	
87	PADZA	5905010060078	81349	RNC50J1822FS	RESISTOR, FIXED, FILM.....	1	
88	XDDZZ		81349	RNC50J1871FS	RESISTOR, FIXED, FILM.....	1	
89	PADZZ	5905011276300	81349	RNC50J1872FS	RESISTOR, FIXED, FILM.....	1	
90	XDDZZ		81349	RNC50J1911FS	RESISTOR, FIXED, FILM.....	1	
91	PADZA	5905001828101	81349	RNC50J1912FS	RESISTOR, FIXED, FILM.....	1	
92	PADZZ	5905010068517	81349	RNC50J1782FS	RESISTOR, FIXED, FILM.....	1	
93	PADZA	5905002851401	81349	RNC50J1781FS	RESISTOR, FIXED, FILM.....	1	
94	PADZZ	5905001828102	81349	RNC50J2001FS	RESISTOR, FIXED, FILM.....	1	
95	PADZZ	5905010367847	81349	RNC50J2051FS	RESISTOR, FIXED, FILM.....	1	
96	XDDZZ		81349	RNC50J2101FS	RESISTOR, FIXED, FILM.....	1	
97	PADZZ	5905003206632	81349	RNC50J2151FS	RESISTOR, FIXED, FILM.....	1	
98	PADZA	5905002850616	81349	RNC50J2211FS	RESISTOR, FIXED, FILM.....	1	
99	PADZA	5905003061800	81349	RNC50J1821FS	RESISTOR, FIXED, FILM.....	1	
100	PADZZ	5905011551563	81349	RNC50J1621FS	RESISTOR, FIXED, FILM.....	1	
101	PADZA	5905007582947	81349	RNC50J1622FS	RESISTOR, FIXED, FILM.....	1	
102	PADZZ	5905004439370	81349	RNC50J1502FS	RESISTOR, FIXED, FILM.....	1	

SECTION II		TM9-1290-365-24&P				
(1)	(2)	(3)	(4)	(5)	(6)	(7)
ITEM	SMR			PART		
NO	CODE	NSN	CAGEC	NUMBER	DESCRIPTION AND USABLE ON CODES (UOC)	QTY
103	PADZA	5905001859134	81349	RNC50J1541FS	RESISTOR, FIXED, FILM.....	1
104	PADZZ	5905001828100	81349	RNC50J1542FS	RESISTOR, FIXED, FILM.....	1
105	XDDZZ		81349	RNC50J1581FS	RESISTOR, FIXED, FILM.....	1
106	PADZA	5905005816461	81349	RNC50J1582FS	RESISTOR, FIXED, FILM.....	1
107	PADZZ	5905002851310	81349	RNC50J1501FS	RESISTOR, FIXED, FILM.....	1
108	PADZA	5905001854094	81349	RNC50J1742FS	RESISTOR, FIXED, FILM.....	1
109	XDDZZ		81349	RNC50J1651FS	RESISTOR, FIXED, FILM.....	1
110	PADZA	5905001890729	81349	RNC50J1652FS	RESISTOR, FIXED, FILM.....	1
111	PADZZ	5905010172861	81349	RNC50J1691FS	RESISTOR, FIXED, FILM.....	1
112	XDDZA		81349	RNC50J1692FS	RESISTOR, FIXED, FILM.....	1
113	PADZZ	5905010199500	81349	RNC50J1741FS	RESISTOR, FIXED, FILM.....	1
114	PADZZ	5905011748473	81349	RWR81S8R25FS	RESISTOR, FIXED, WIRE.....	1
115	PADZZ	5905011863783	81349	RLR05C4751FS	RESISTOR, FIXED, FILM.....	4
116	PADZZ	5905011405573	81349	RWR81SR619FS	RESISTOR, FIXED, WIRE.....	1
117	PADZZ	5905011864912	81349	RLR05C4752FS	RESISTOR, FIXED, FILM.....	2
118	PADZZ	5905011690047	81349	RLR05C1003FS	RESISTOR, FIXED, FILM.....	1
119	PADZZ	5905014455923	81349	RLR05C4753FR	RESISTOR, FIXED, FILM.....	1
120	PADZZ	5905012025861	81349	RLR05C10R0GS	RESISTOR, FIXED, FILM.....	6
121	PADZZ	5905011867774	81349	RLR05C2491FS	RESISTOR, FIXED, FILM.....	1
122	PADZZ	5905012134134	81349	RLR05C7502GS	RESISTOR, FIXED, FILM.....	1
123	PADZZ	5905013888231	81349	RWR81SR200FR	RESISTOR, FIXED, WIRE.....	1
124	PADZZ	5905011738932	81349	RLR05C4701GS	RESISTOR, FIXED, FILM.....	1
125	PADZZ	5905011851319	81349	RLR05C4750FS	RESISTOR, FIXED, FILM.....	1
126	PADZZ	5905012444465	81349	RLR05C5R10GS	RESISTOR, FIXED, FILM.....	1
127	PADZZ	5905011700388	81349	RLR05C2492FS	RESISTOR, FIXED, FILM.....	1
128	PADZZ	5905004124049	81349	RNC55H4751FS	RESISTOR, FIXED, FILM.....	1
129	PADZZ	5905012668951	81349	RLR05C1241FS	RESISTOR, FIXED, FILM.....	1
130	PADZZ	5905004683020	81349	RNC55H4531FS	RESISTOR, FIXED, FILM.....	1
131	PADZZ	5905012613758	81349	RLR05C2551FS	RESISTOR, FIXED, FILM.....	1
132	PADZZ	5905010158085	81349	RLR05C1001FS	RESISTOR, FIXED, FILM.....	5
133	PADZZ	5905011767343	81349	RLR05C47R0GS	RESISTOR, FIXED, FILM.....	2
134	PADZZ	5905010824272	81349	RWR81S1001FS	RESISTOR, FIXED, WIRE.....	4
135	PADZZ	5905004212921	81349	RNC50H1000FS	RESISTOR, FIXED, FILM.....	1
136	PADZZ	5905011866677	81349	RLR05C4022FS	RESISTOR, FIXED, FILM.....	1
137	PADZZ	5905011700376	81349	RLR05C8251FS	RESISTOR, FIXED, FILM.....	1
138	PADZZ	5905004439270	81349	RNC50H2001FS	RESISTOR, FIXED, FILM.....	1
139	PADZZ	5905011871636	81349	RLR05C56R2FS	RESISTOR, FIXED, FILM.....	2
140	PADZZ	5905007582925	81349	RNC50H2002FS	RESISTOR, FIXED, FILM.....	2
141	PADZZ	5905011686520	81349	RLR05C20R0FS	RESISTOR, FIXED, FILM.....	1
142	PADZZ	5905011690036	81349	RWR81SR100FS	RESISTOR, FIXED, WIRE.....	1
143	PADZZ	5905011767346	81349	RLR05C6200GS	RESISTOR, FIXED, FILM.....	2
144	PADZZ	5950014478133	S7040	TM6707405-0	TRANSFORMER, CURRENT.....	4
145	XADZZ		S7040	TM6707406-0	TRANSFORMER.....	1
146	PADZZ	5950014478132	S7040	TM6707407-0	COIL, ELECTRICAL.....	1
147	PADZZ	5950014478136	S7040	TM6707408-0	TRANSFORMER, CURRENT.....	1
148	PADZZ	5950014478134	S7040	TM6707409-0	TRANSFORMER, CURRENT.....	1
149	XADZZ		S7040	TM6707410-0	TRANSFORMER.....	1
150	XADZZ		S7040	TM6707411-0	TRANSFORMER.....	1
151	PADZZ	5840014426197	24355	OP221AZ/883B	AMPLIFIER, DUAL LOW.....	2
152	PADZZ	5962012897408	12969	UC1843J/883B	MICROCIRCUIT, LINEAR.....	1
153	PADZZ		81349	M38510/10708BYC	MICROCIRCUIT, LINEAR.....	1
154	PADZA	5962011364640	49956	952536-3	MICROCIRCUIT, LINEAR.....	1

SECTION II			TM9-1290-365-24&P			
(1)	(2)	(3)	(4)	(5)	(6)	(7)
ITEM	SMR			PART		
NO	CODE	NSN	CAGEC	NUMBER	DESCRIPTION AND USABLE ON CODES (UOC)	QTY
155	PADZZ	5962011263888	27014	LM158AJ/883C	MICROCIRCUIT, LINEAR.....	1
156	PADZZ	5962011604990	27014	LM136AH-2.5/883B	MICROCIRCUIT, LINEAR.....	2
157	XADZZ		S7040	PC6707306-0	PRINTED WIRE BOARD.....	1
158	XADZZ		S7040	AM6707435-0	HEATSINK, ELECTRICAL.....	3
159	PADZZ	5305000545648	96906	MS51957-14	SCREW, MACHINE.....	11
160	PADZZ	5310000570573	80205	NAS620C4	WASHER, FLAT.....	15
161	PADZZ	5310002083786	80205	NAS671C4	NUT, PLAIN, HEXAGON.....	4
162	PADZZ	5310009338118	96906	MS35338-135	WASHER, LOCK.....	3
163	XADZZ		S7040	MP6706606-0	SPACER.....	4
164	PADZZ	5999014489825	S7040	MP6706616-0	HEAT SINK, ELECTRICAL.....	2
165	PADZZ	5970012231416	18565	60-11-4374-1674	INSULATOR, DISK.....	2
166	PADZZ	5999010153901	81349	M38527/01-030D	MOUNTING PAD, ELECTR.....	4
167	PADZZ	5970014479867	S7040	MP6706581-0	INSULATOR, PLATE.....	2

END OF FIGURE

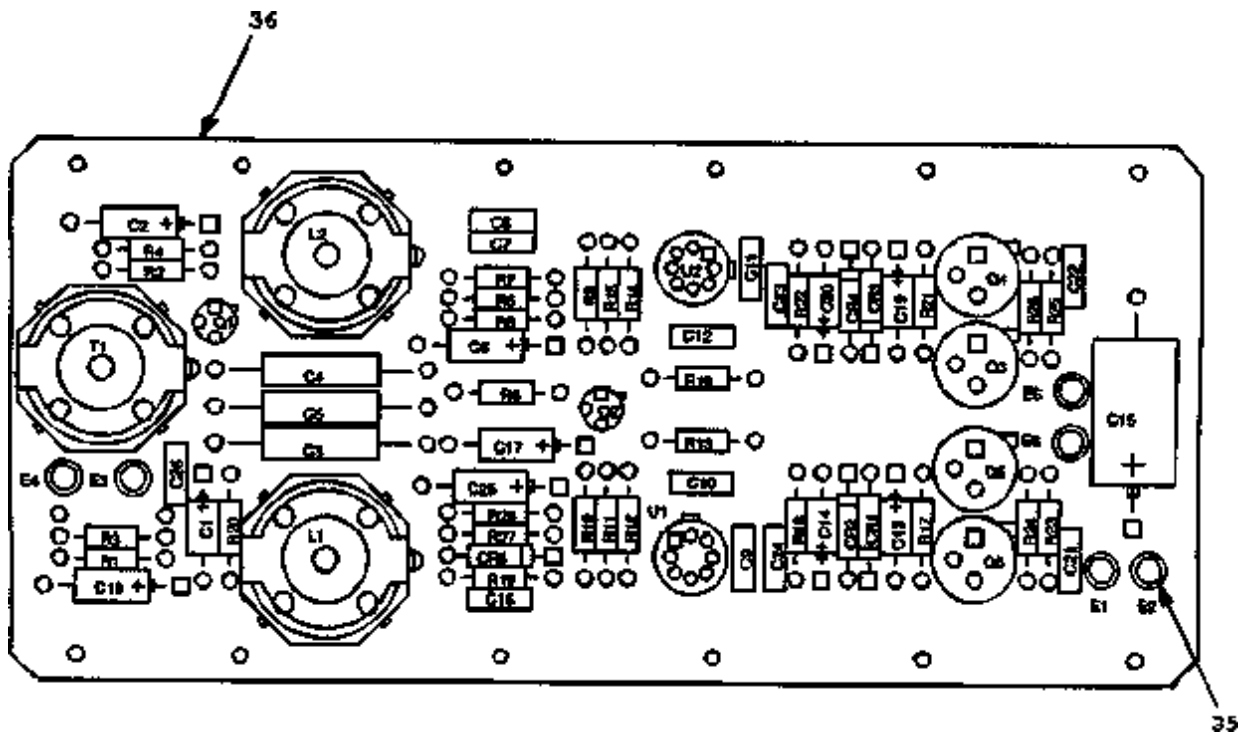

Figure C-5. Doppler Amplifier CCA, P/N AY6706566-0 (Sheet 1 of 2)

LEGEND

REF DES	ITEM NO.	REF DES	ITEM NO.	REF DES	ITEM NO.
C1	1	C24	9	RB	29
C2	5	C25	5	R9	30
C3	8	C26	7	R10	18
C4	34	CR1	12	R11	19
C5	8	CR2	12	R12	18
C6	5	CR3	12	R13	19
C7	9	CR4	12	R14	18
C8	10	CR5	13	R15	18
C9	11	L1	14	R16	19
C10	2	L2	14	R17	27
C11	11	Q1	15	R18	27
C12	2	Q2	15	R19	20
C13	1	Q3	16	R20	22
C14	1	Q4	17	R21	27
C15	3	Q5	16	R22	27
C16	4	Q6	17	R23	23
C17	5	R1	33	R24	23
C18	5	R2	21	R25	23
C19	1	R3	26	R26	23
C20	1	R4	21	R27	24
C21	6	R5	33	R28	25
C22	6	R6	27	T1	31
C23	9	R7	28		

Figure C-5. Doppler Amplifier CCA, P/N AY 6706566-0 (Sheet 2 of 2)



SECTION II			TM9-1290-365-24&P			
(1)	(2)	(3)	(4)	(5)	(6)	(7)
ITEM	SMR			PART		
NO	CODE	NSN	CAGEC	NUMBER	DESCRIPTION AND USABLE ON CODES(UOC)	QTY
FIG. C-5 DOPPLER AMPFIFIER CCA, (P/N AY6706566-0)						
1	PADZF	5910004950042	81349	M39003-01-3076	CAPACITOR, FIXED, ELE.....	5
2	PADZZ	5910012380381	81349	CCR05CJ4R7BS	CAPACITOR, FIXED, CER.....	2
3	PADZZ	5910012330730	81349	M39003/01-8121	CAPACITOR, FIXED, ELE.....	1
4	PADZZ	5910000108666	81349	M39014/01-1357	CAPACITOR, FIXED, CER.....	1
5	PADZZ	5910012393994	81349	M39003/01-8078	CAPACITOR, FIXED, ELE.....	5
6	PADZZ	5910000108721	81349	M39014/02-1419	CAPACITOR, FIXED, CER.....	2
7	PADZZ	5910001135465	81349	M39014/02-1360	CAPACITOR, FIXED, CER.....	1
8	PADZZ	5910012178875	81349	M83421/01-4051S	CAPACITOR, FIXED, MET.....	2
9	PADZZ	5910001135286	81349	M39014/02-1356	CAPACITOR, FIXED, CER.....	3
10	PADZZ	5910012154597	81349	CCR05CG101FS	CAPACITOR, FIXED, CER.....	1
11	PADZZ	5910003059515	81349	M39014/01-1583	CAPACITOR, FIXED, CER.....	2
12	PADZZ	5961005844527	81349	JANTX1N4148-1	SEMICONDUCTOR DEVIC.....	4
13	PADZZ	5961011050608	81349	JANTX1N965B-1	SEMICONDUCTOR DEVIC.....	1
14	XADZZ		S7040	TM6706568-0	INDUCTOR, DOPPLER.....	2
15	PADZZ	5961000225669	81349	JANTX2N930	TRANSISTOR.....	2
16	PADZZ	5961011793470	81349	JANTX2N2219AL	TRANSISTOR.....	2
17	PADZZ	5961011878836	81349	JANTX2N2905AL	TRANSISTOR.....	2
18	PADZZ	5905011466671	81349	RLR07C1502GS	RESISTOR, FIXED, FILM.....	4
19	PADZZ	5905011395316	81349	RLR07C2203GS	RESISTOR, FIXED, FILM.....	3
20	PADZZ	5905011370108	81349	RLR07C2700GS	RESISTOR, FIXED, FILM.....	1
21	PADZZ	5905010535789	81349	RLR07C1201GS	RESISTOR, FIXED, FILM.....	2
22	PADZZ	5905011386261	81349	RLR07C3301GS	RESISTOR, FIXED, FILM.....	1
23	PADZZ	5905011694098	81349	RLR07C15R0GS	RESISTOR, FIXED, FILM.....	4
24	PADZZ	5905011659845	81349	RLR07C6801GS	RESISTOR, FIXED, FILM.....	1
25	PADZZ	5905011395314	81349	RLR07C1002GS	RESISTOR, FIXED, FILM.....	1
26	PADZZ	5905011620731	81349	RLR07C2702GS	RESISTOR, FIXED, FILM.....	1
27	PADZZ	5905011491143	81349	RLR07C5601GS	RESISTOR, FIXED, FILM.....	5
28	PADZZ	5905011466673	81349	RLR07C1802GS	RESISTOR, FIXED, FILM.....	1
29	PADZZ	5905011486092	81349	RLR07C1501GS	RESISTOR, FIXED, FILM.....	1
30	PADZZ	5905011370109	81349	RLR07C4702GS	RESISTOR, FIXED, FILM.....	1
31	XADZZ		S7040	TM6706567-0	TRANSFORMER.....	1
32	PADZZ	5962012879492	81349	M38510/10107BGA	MICROCIRCUIT, LINEAR.....	2
33	PADZZ	5905011464349	81349	RLR07C8202GS	RESISTOR, FIXED, FILM.....	2
34	PADZZ	5910012657630	81349	M83421/01-4039S	CAPACITOR, FIXED, MET.....	1
35	PADZZ	5940012216415	81349	SE11XC01S	TERMINAL, STUD.....	6
36	XADZZ		S7040	PC6706565-0	PRINTED WIRE BOARD.....	1

END OF FIGURE



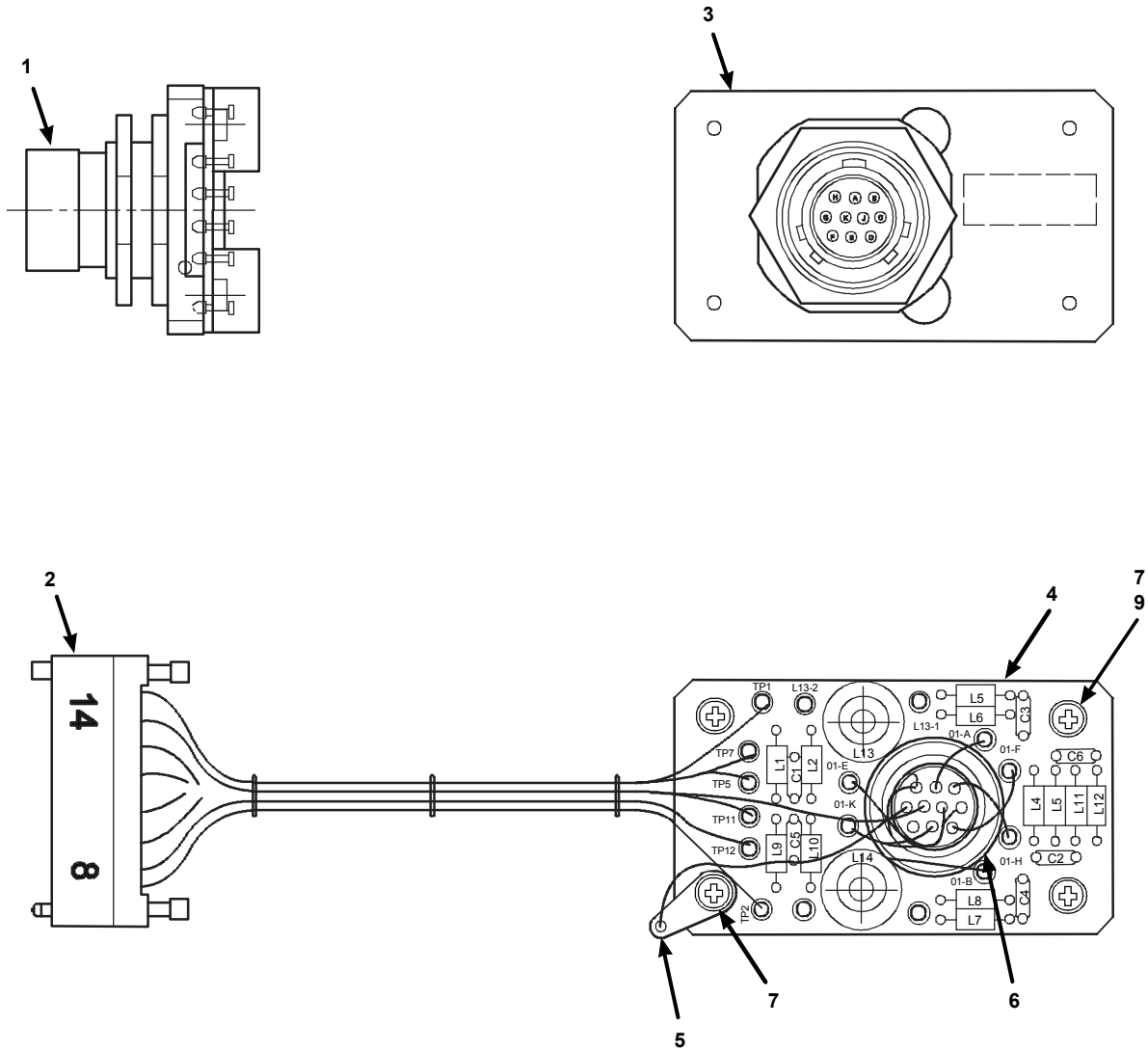
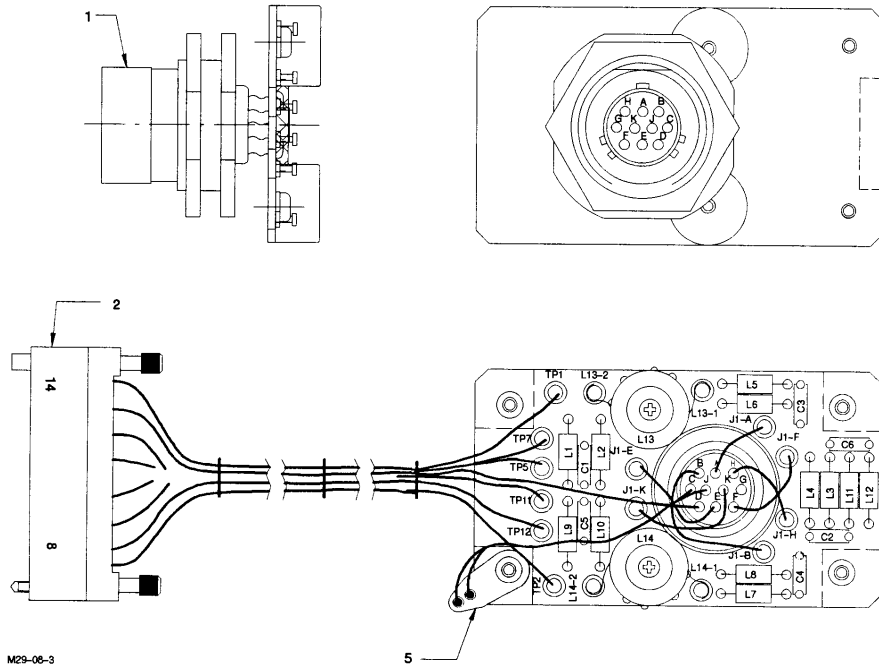

Figure C-6. EMI Filter Module, P/N AY6707289-1, AY6707289-3 (Sheet 1 of 2)



M29-06-3

Figure C-6 EMI Filter Module, AY6707289-3 (Sheet 2 of 2)

SECTION II			TM9-1290-365-24&P,C01		(6)	(7)
(1)	(2)	(3)	(4)	(5)		
ITEM	SMR			PART		
NO	CODE	NSN	CAGEC	NUMBER	DESCRIPTION AND USABLE ON CODES(UOC) QTY	

FIG. C-6 EMI FILTER MODULE,  
P/N AY6707289-1, AY6707289-3

1	PADZA	5935011475741	81349	D38999/24WC98PN	CONNECTOR,RECEPTACL.....	1
2	PADZZ	5935014472744	81349	M55302/66L14H	CONNECTOR,RECEPTACL.....	1
3	XADZZ		S7040	AM6708191-0	HOLDER,EMI BOARD.....	1
4	XADZZ		S7040	AY6708194-0	CIRCUIT CARD ASSEMB.....	1
5	PADZZ	5940006822477	96906	MS77068-1	TERMINAL,LUG.....	1
6	XADZZ		S7040	MP6706700-1	NUT,GROMMET.....	1
7	PADZZ	5305000545647	96906	MS51957-13	SCREW,MACHINE.....	4
8	PADZZ	5310000570573	80205	NAS620C4	WASHER,FLAT.....	3
				AY6707289-3		
				AY6707289-1		

END OF FIGURE



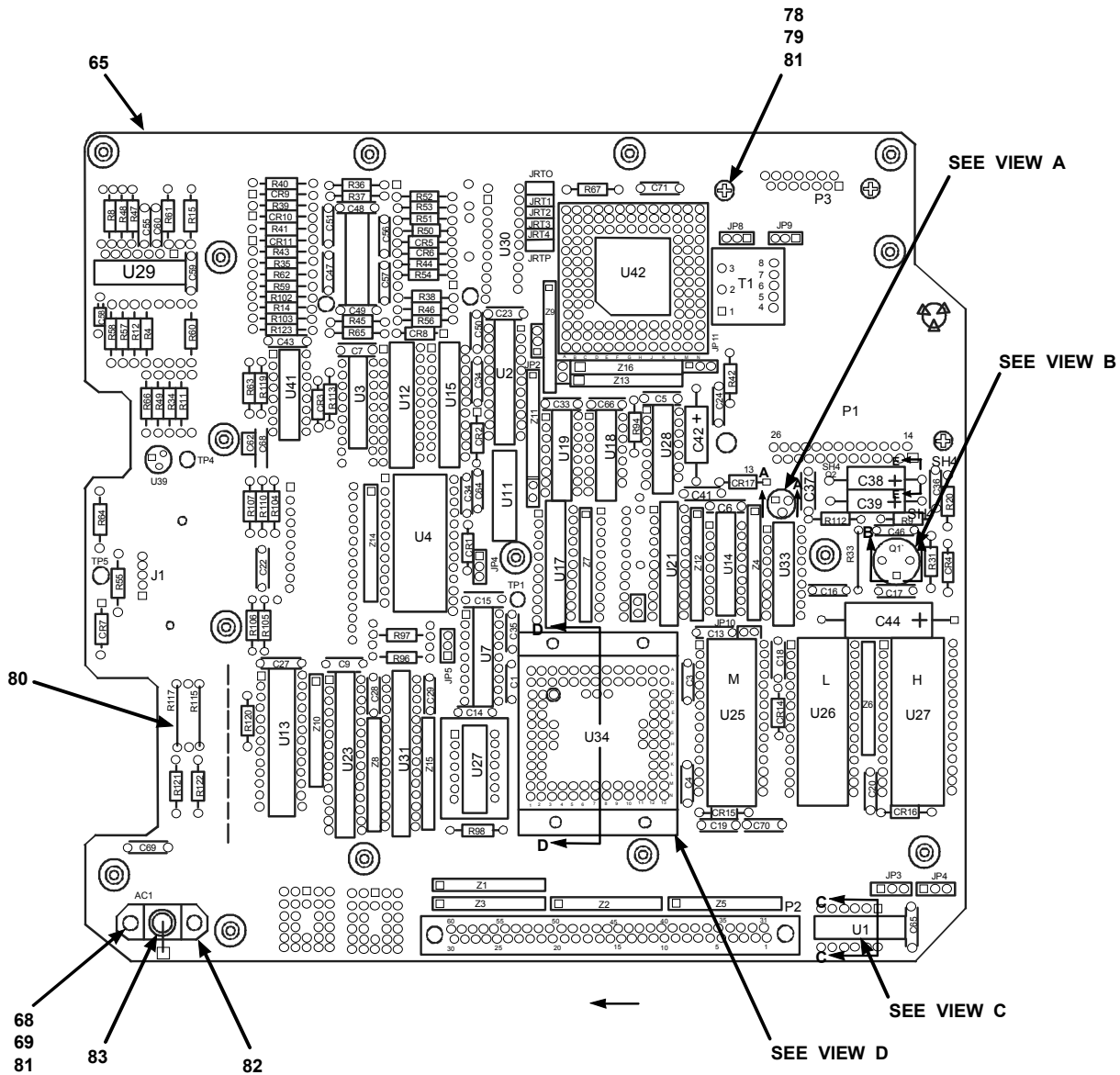
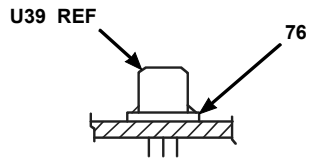
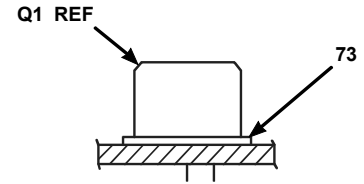

Figure C-7. Muzzle Velocity Processor CCA, P/N AY67010314 (Sheet 1 of 4)



DETAIL VIEW A  
2 PL (Q2, U29)



DETAIL VIEW B

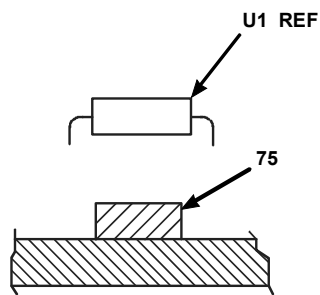

DETAIL VIEW C  
24 PL (U1-U4, U7, U11-U15, U17-U19,  
U21, U22-U26, U28, U31, U33, U36,  
U41)

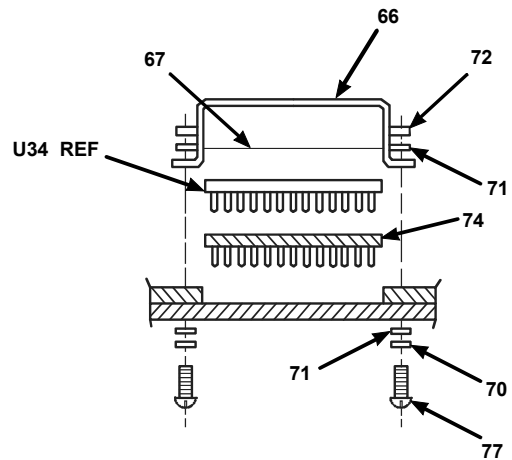

DETAIL VIEW D

Figure C-7. Muzzle Velocity Processor CCA, P/N AY67010314 (Sheet 2 of 4)



LEGEND

REF DES	ITEM NO.	REF DES	ITEM NO.	REF DES	ITEM NO.
C1	1	C50	5	R9	1B
C2	1	C51	5	R12	33
C3	1	C55	7	R14	22
C4	1	C56	8	R15	22
C5	1	C57	8	R20	34
C6	1	C58	9	R31	23
C7	1	C59	1	R34	24
C9	1	C60	1	R35	25
C10	1	C62	6	R36	25
C13	1	C64	1	R37	26
C14	1	C65	1	R38	26
C15	1	C66	1	R39	26
C16	1	C68	1	R40	28
C17	1	C69	1	R41	28
C18	1	C70	1	R42	29
C19	1	C71	1	R43	26
C20	1	CR1	10	R44	29
C22	1	CR2	10	R45	26
C23	1	CR3	10	R46	26
C24	1	CR4	10	R47	26
C27	1	CR5	11	R48	26
C28	1	CR6	11	R49	27
C29	1	CR7	10	R50	30
C33	1	CR8	10	R51	26
C34	1	CR9	12	R52	26
C35	1	CR10	12	R53	31
C36	1	CR11	12	R54	31
C37	1	CR14	10	R55	26
C38	2	CR15	10	R56	27
C39	2	CR16	10	R57	32
C41	1	CR17	10	R58	26
C42	3	P1	13	R59	26
C43	1	P2	14	R60	25
C44	4	P3	15	R61	25
C46	1	Q1	16	R62	26
C47	1	Q2	17	R63	35
C48	1	R4	27	R64	24
C49	1	R8	R65	33	24

Figure C-7. Muzzle Velocity Processor CCA, P/N AY67010314 (Sheet 3 of 4)

LEGEND

REF DES	ITEM NO.	REF DES	ITEM NO.	REF DES	ITEM NO.
R66	26	TP3	37	U29	51
R94	27	TP4	37	U31	45
R96	27	TP5	37	U33	59
R97	27	U1	63	U34	62
R98	27	U2	43	U36	53
R102	25	U3	63	U39	60
R103	19	U4	56	U41	51
R104	18	U5	57	U42	52
R105	18	U7	58	Z1	62
R106	18	U11	38	Z2	62
R107	18	U12	55	Z3	62
R110	18	U13	54	Z4	62
R111	27	U14	39	Z5	62
R112	26	U15	55	Z6	62
R113	19	U17	40	Z7	62
R118	18	U18	41	Z8	62
R119	26	U19	42	Z9	62
R120	27	U21	44	Z10	62
R121	21	U23	45	Z11	61
R122	21	U24	46	Z12	61
R123	27	U25	47	Z13	61
T1	36	U26	48	Z14	61
TP1	37	U27	49	Z15	61
TP2	37	U28	50	Z16	61

Figure C-7. Muzzle Velocity Processor CCA, P/N AY67010314 (Sheet 4 of 4)

(1)	(2)	(3)	(4)	(5)	(6)	(7)
ITEM	SMR	NSN	CAGEC	PART	DESCRIPTION AND USABLE ON CODES(UOC)	QTY
NO	CODE			NUMBER		

FIG. C-7 MUZZLE VELOCITY PROCESS  
CCA, P/N AY67010314

1	PADZZ	5910011718693	81349	M39014/22-1094	CAPACITOR, FIXED, CER.....	43
2	PADZZ	5910012243023	81349	M39003/01-8214	CAPACITOR, FIXED, ELE.....	2
3	PADZZ	5910012456446	81349	M39003/01-8032	CAPACITOR, FIXED, ELE.....	1
4	PADZZ	5910012710897	81349	M39003/03-3025	CAPACITOR, FIXED, ELE.....	1
5	PADZZ	5910012127847	81349	M39014/22-1079	CAPACITOR, FIXED, CER.....	2
6	PADZZ	5910012141009	81349	CCR05CG681FS	CAPACITOR, FIXED, CER.....	1
7	PADZZ	5910012264614	81349	M39014/22-0975	CAPACITOR, FIXED, CER.....	1
8	PADZZ	5910011716524	81349	M39014/22-1011	CAPACITOR, FIXED, CER.....	2
9	PADZZ	5910012219889	81349	CCR05CJ6R8BS	CAPACITOR, FIXED, CER.....	1
10	PADZZ	5961005844527	81349	JANTX1N4148-1	SEMICONDUCTOR DEVIC.....	10
11	XDDZZ		81349	JANTX1N756A	SEMICONDUCTOR DEVIC.....	2
12	PADZZ	5961010708942	81349	JANTX1N758A-1	SEMICONDUCTOR DEVIC.....	3
13	PADZZ	5935011379041	81349	M55302/61-B26	CONNECTOR, RECEPTACL.....	1
14	PADZA	5935010743386	81349	M55302/64-B60F	CONNECTOR, RECEPTACL.....	1
15	PADZA	5935011368097	81349	M55302/61-B14	CONNECTOR, RECEPTACL.....	1
16	PADZZ	5961011878836	81349	JANTX2N2905AL	TRANSISTOR.....	1
17	PADZA	5961008583826	81349	JANTX2N2222A	TRANSISTOR.....	1
18	PADZZ	5905011511187	81349	RLR07C1003GS	RESISTOR, FIXED, FILM.....	7
19	PADZZ	5905011600032	81349	RLR07C2401GS	RESISTOR, FIXED, FILM.....	1
20	PADZZ	5905011687801	81349	RLR07C4301GS	RESISTOR, FIXED, FILM.....	1
21	PADZZ	5905007210815	81349	RNC55J5112BS	RESISTOR, FIXED, FILM.....	2
22	PADZZ	5905010535789	81349	RLR07C1201GS	RESISTOR, FIXED, FILM.....	2
23	PADZZ	5905011600932	81349	RLR07C3900GS	RESISTOR, FIXED, FILM.....	1
24	PADZZ	5905010851164	81349	RLR07C1001GS	RESISTOR, FIXED, FILM.....	3
25	PADZZ	5905011836168	81349	RLR07C20R0GS	RESISTOR, FIXED, FILM.....	5
26	PADZZ	5905011395314	81349	RLR07C1002GS	RESISTOR, FIXED, FILM.....	17
27	PADZZ	5905011491143	81349	RLR07C5601GS	RESISTOR, FIXED, FILM.....	10
28	PADZZ	5905011395316	81349	RLR07C2203GS	RESISTOR, FIXED, FILM.....	2
29	PADZZ	5905011370094	81349	RLR07C6800GS	RESISTOR, FIXED, FILM.....	2
30	PADZZ	5905011505515	81349	RLR07C2003GS	RESISTOR, FIXED, FILM.....	1
31	PADZZ	5905011676969	81349	RLR07C1601GS	RESISTOR, FIXED, FILM.....	2
32	PADZZ	5905001219919	81349	RCR07G106JS	RESISTOR, FIXED, COMP.....	1
33	PADZZ	5905011505459	81349	RLR07C2001GS	RESISTOR, FIXED, FILM.....	2
34	PADZZ	5905011620729	81349	RLR07C8201GS	RESISTOR, FIXED, FILM.....	1
35	PADZZ	5905012096528	81349	RLR07C3572FS	RESISTOR, FIXED, FILM.....	1
36	PADZZ	5950012842876	81349	M21038/27-02	TRANSFORMER, PULSE.....	1
37	PADZZ		81349	SE11C01S	TERMINAL, STUD.....	5
38	PADZZ	5962012541149	81349	M38510/65701BCA	MICROCIRCUIT, DIGITA.....	1
39	PADZZ	5962012724446	81349	M38510/65802BEA	MICROCIRCUIT, DIGITA.....	1
40	PADZZ	5962012821049	27014	MM54HC273J/883B	MICROCIRCUIT, DIGITA.....	1
41	PADZZ	5962012008321	27014	MM54HC08J/883B	MICROCIRCUIT, DIGITA.....	1
42	PADZZ	5962011713774	27014	MM54HC32J/883B	MICROCIRCUIT, DIGITA.....	1
43	PADZZ	5962011233186	27014	MM54C244J-MIL	MICROCIRCUIT, DIGITA.....	1
44	PADZZ	5962011233186	27014	MM54C244J-MIL	MICROCIRCUIT, DIGITA.....	1
45	PADZZ	5962014062375	67268	5962-8866203NA	MICROCIRCUIT, MEMORY.....	2
46	MDDZZ		S7040	MC6707420-0	EPROM L.....	1
47	MDDZZ		S7040	MC6707419-0	EPROM M.....	1
48	XADZZ		S7040	MC6707418-0	EPROM H.....	1
49	PADZZ	5955011891019	81349	M55310/16-B41A32	OSCILLATOR.....	1

SECTION II		TM9-1290-365-24&P				
(1)	(2)	(3)	(4)	(5)	(6)	(7)
ITEM NO	SMR CODE	NSN	CAGEC	PART NUMBER	DESCRIPTION AND USABLE ON CODES (UOC)	QTY
				M000		
50	PADZZ	5962012773331	81349	M38510/65702BCA	MICROCIRCUIT, DIGITA.....	1
51	PADZZ	5962012862238	81349	M38510/11201BCA	MICROCIRCUIT, LINEAR.....	2
52	XDDZZ		02598	CT2577-10-QM-P119	BUS CONTROLLER.....	1
53	PADZZ	5962011820577	22915	340475	MICROCIRCUIT, LINEAR.....	1
54	MDDZZ		S7040	MC6707417-0	PAL (U13).....	1
55	PADZZ	5962011894489	19200	9255736	MICROCIRCUIT, DIGITA.....	2
56	PADZZ	5962012803480	34371	MD82C54/B	MICROCIRCUIT, DIGITA.....	1
57	PADZZ		34649	MD8215A/B	MICROCIRCUIT.....	1
58	PADZZ	5962013723606	67268	5962-8956101EA	MICROCIRCUIT, DIGITA.....	1
59	PADZZ	5962014208941	67268	5962-9071103MEA	MICROCIRCUIT, LINEAR.....	1
60	PADZZ	5962011604990	64155	LM136AH-2.5/883	MICROCIRCUIT, LINEAR.....	1
61	PADZZ	5905012794826	81349	M8340109K5601GC	RESISTOR NETWORK, FI.....	6
62	PADZZ	5905013750573	81349	M8340109K2211FC	RESISTOR NETWORK, FI.....	10
63	PADZZ	5962013943454	51640	ADSP-2100ASG/883B	MICROCIRCUIT, DIGITA.....	1
64	XDDZZ		04713	MM54HC164/BCAJC	MICROCIRCUIT, DIGITA.....	2
65	XADZZ		S7040	PC6707307-0	PRINTED WIRE BOARD.....	1
66	XADZZ		S7040	MP6706582-0	HOUSING DISPLAY.....	1
67	PADZZ	5640014491938	S7040	MP6706583-0	INSULATION BLANKET.....	1
68	PADZZ	5310007239676	80205	NAS620C4L	WASHER, FLAT.....	6
69	PADZZ	5305000545649	96906	MS51957-15	SCREW, MACHINE.....	6
70	PADZZ	5310009282690	96906	MS35338-134	WASHER, LOCK.....	4
71	PADZZ	5310000434708	80205	NAS620C2	WASHER, FLAT.....	8
72	PADZZ	5310008124294	80205	NAS671C2	NUT, PLAIN, HEXAGON.....	4
73	PADZZ	5999010540593	58536	A-55485/02-004D	MOUNTING PAD, ELECTR.....	1
74	PADZZ	5935014489752	91506	PPS101-1A1321L	SOCKET, PLUG-IN ELEC.....	1
75	PADZA	5970014640254	76381	75 1/2	TAPE, INSULATION, ELE.....	1
76	PADZZ	5999010153901	81349	M38527/01-030D	MOUNTING PAD, ELECTR.....	2
77	PADZZ	5305000545639	96906	MS51957-5	SCREW, MACHINE.....	4
78	PADZZ	5310002083786	80205	NAS671C4	NUT, PLAIN, HEXAGON.....	4
79	PADZZ	6145006696564	81348	QQW343S22S1B	WIRE, ELECTRICAL.....	1
80	PADZZ	5310009338118	96906	MS35338-135	WASHER, LOCK.....	2
81	PADZZ	5935014465272	S7040	MP6707844-0	RETAINER, ELECTRICAL.....	1
82	PADZZ	5930014444571	S7040	WT6707886-0	SWITCH, ELECTRONIC.....	1

END OF FIGURE



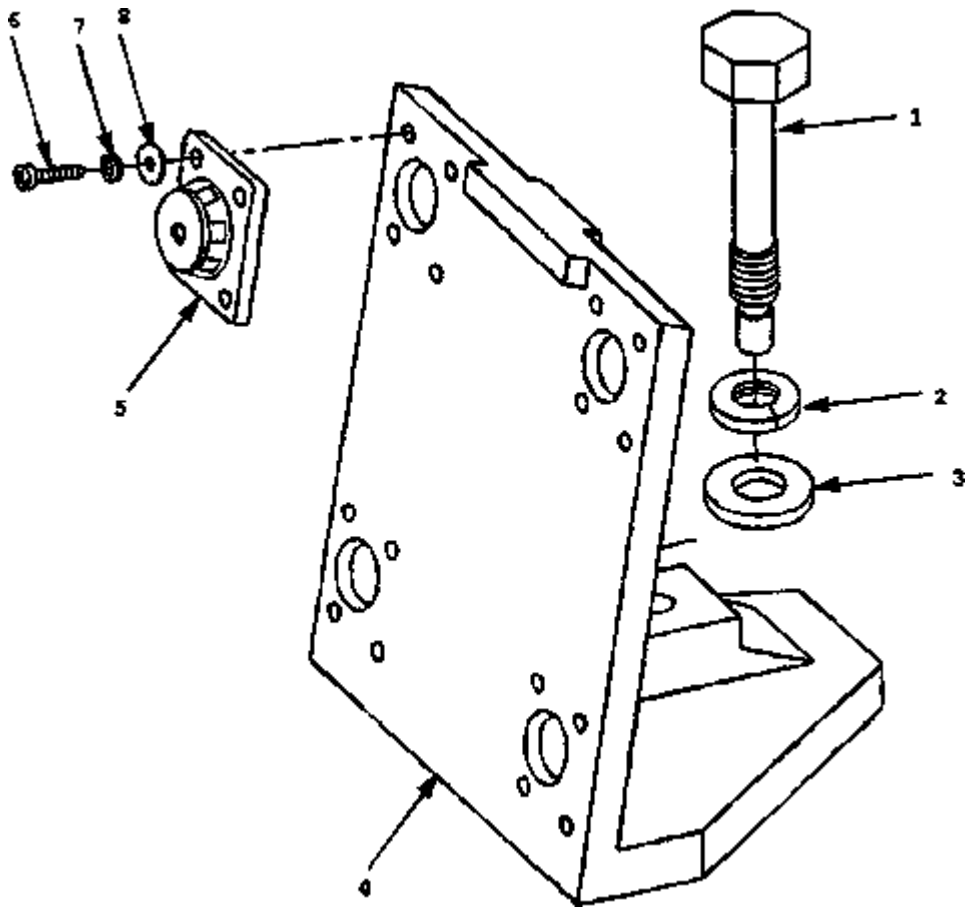
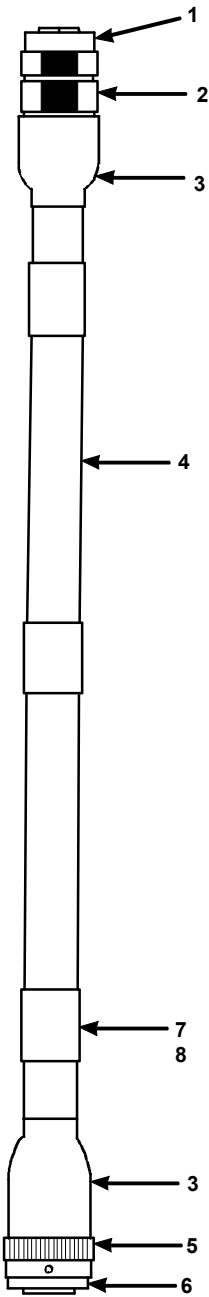

Figure C-8. Bracket Assembly, P/N 12979003

SECTION II			TM9-1290-365-24&P			
(1)	(2)	(3)	(4)	(5)	(6)	(7)
ITEM	SMR			PART		
NO	CODE	NSN	CAGEC	NUMBER	DESCRIPTION AND USABLE ON CODES (UOC)	QTY
FIG. C-8 BRACKET ASSEMBLY, P/N 12979003						
1	PAOZZ	5306014461596	19200	12979008	BOLT, EXTERNALLY REL.....	1
2	PAOZZ	5310009338778	96906	MS35338-143	WASHER, LOCK.....	1
3	PAOZZ	5310007679425	96906	MS15795-818	WASHER, FLAT.....	1
4	XDOZZ		19200	12922096	BRACKET, MOUNTING.....	1
5	PAOZZ	5342009850248	19200	12922110	MOUNT, RESILIENT.....	4
6	PAOZZ	5305000546669	96906	MS51957-44	SCREW, MACHINE.....	16
7	PAOZZ	5310009338119	96906	MS35338-137	WASHER, LOCK.....	16
8	PAOZZ	5310008805975	81349	REW620C8L	WASHER, FLAT.....	16

END OF FIGURE



MV50O6IWA6707294-0

Figure C-9. Power and Data Cable (0.75-Meter), P/N 12979004



SECTION II			TM9-1290-365-24&P			
(1)	(2)	(3)	(4)	(5)	(6)	(7)
ITEM	SMR			PART		
NO	CODE	NSN	CAGEC	NUMBER	DESCRIPTION AND USABLE ON CODES(UOC)	QTY
FIG. C-9 POWER AND DATA CABLE (0.75 METER), P/N 12979004						
1	PAFZA	5935011227585	81349	D38999/26WC98SN	CONNECTOR, PLUG, ELEC.....	1
2	PAFZZ		06090	209M312-19B	ADAPTER.....	1
3	PAFZZ	5975012916323	06090	202S142-25S	BOOT, DUST AND MOIST.....	2
4	PAFZZ		S7040	EPD-RWC-10654	CABLE.....	1
5	PAFZZ	5935012239820	06090	201M112-19B	ADAPTER, CABLE CLAMP.....	1
6	PAFZZ	5935011078811	96906	MS3476W12-10P	CONNECTOR, PLUG, ELEC.....	1
7	PAFZZ	5970008715779	81349	M23053/5-208-C	INSULATION SLEEVING.....	1
8	PAFZZ	5970013555982	06090	TMS-SCE 1/2-2.09	INSULATION SLEEVING.....	1

END OF FIGURE



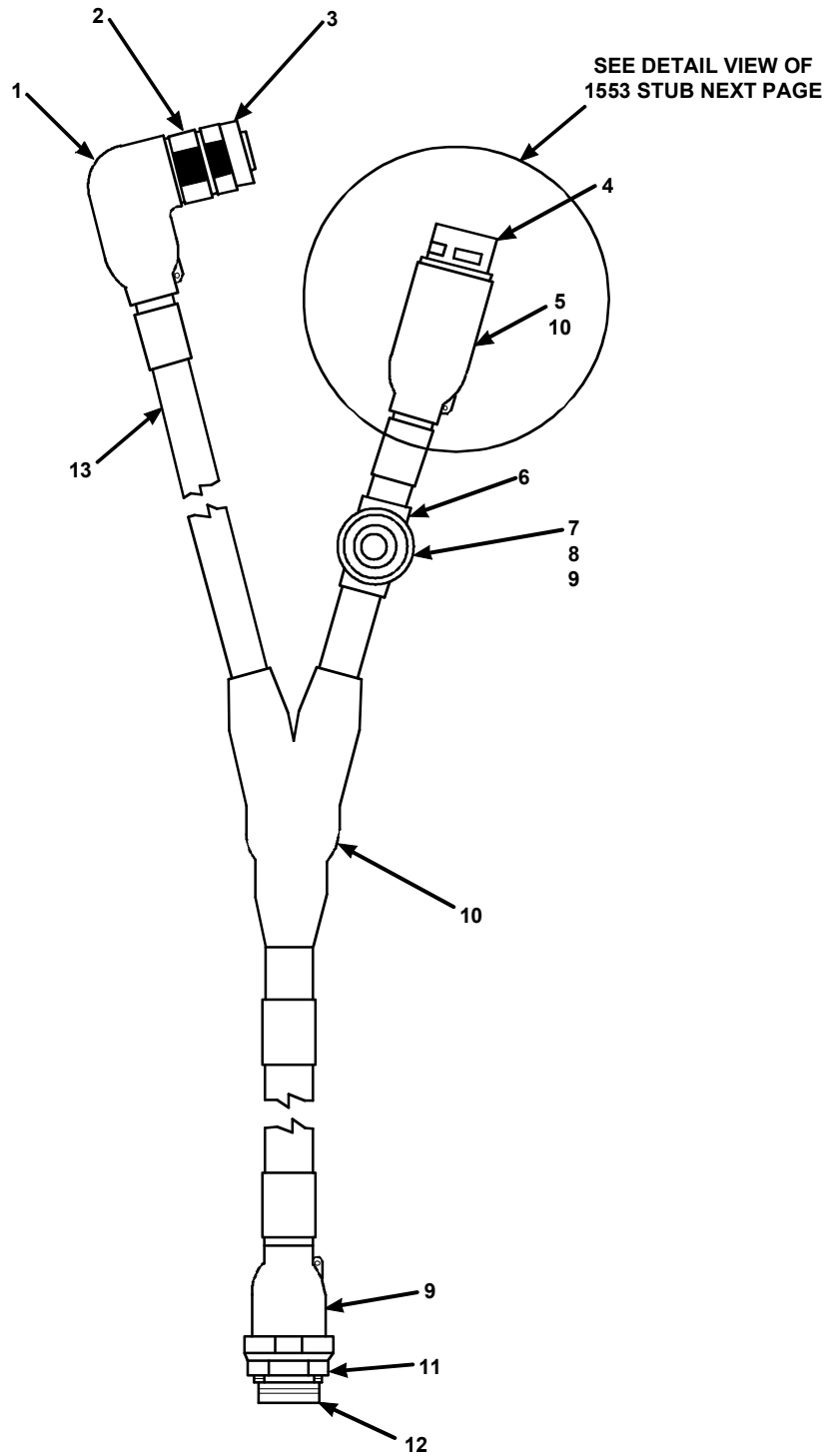
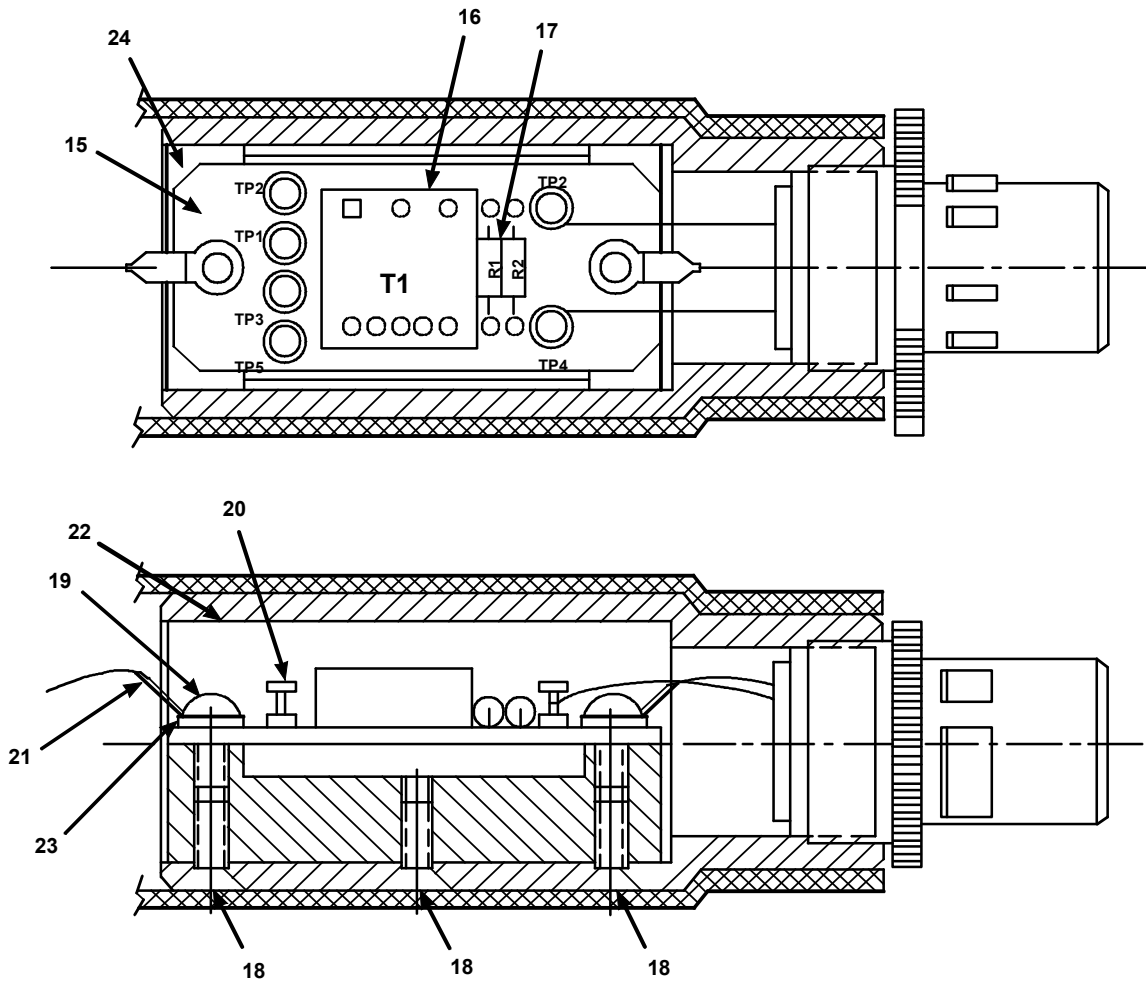

Figure C-10. Power and Data Cable (5-Meter), P/N 12991852 (Sheet 1 of 2)



DETAIL VIEW OF 1553 STUB

Figure C-10. Power and Data Cable (5 Meter), P/N 12991852 (Sheet 2 of 2)

SECTION II			TM9-1290-365-24&P,C01			
(1)	(2)	(3)	(4)	(5)	(6)	(7)
ITEM	SMR			PART		
NO	CODE	NSN	CAGEC	NUMBER	DESCRIPTION AND USABLE ON CODES(UOC)	QTY

FIG. C-10 POWER AND DATA CABLE  
(5-METER), P/N 12991852

1	PAFZZ	5975013858686	06090	222S152-25S	CABLE NIPPLE,ELECTR.....	1
2	PAFZZ	5935014596068	06090	209M418-19B	ADAPTER.....	1
3	PAFZA	5935012611503	81349	D38999/46WF32PA	CONNECTOR,PLUG,ELEC.....	1
4	PAFZA	5935014503707	81349	D38999/49WD97PD	CONNECTOR,RECEPTACL.....	1
5	PAFZZ	5340014501988	06090	202S163-25S	BOOT,DUST AND MOIST.....	1
6	PAFZZ	5970009237173	06090	301A022-3	INSULATION SLEEVING.....	1
7	PAFZA	5935014503063	81349	D38999/46WD97SD	CONNECTOR BODY,PLUG.....	1
8	PAFZZ	5935014748331	06090	TXR40AB90-1406BI	ADAPTER,CONNECTOR.....	1
9	PAFZZ	5975012916323	06090	202S142-25S	BOOT,DUST AND MOIST.....	2
10	PAFZZ	5970013765868	9K946	382S023-3S	INSULATION SLEEVING.....	1
11	PAFZZ	5935012239820	06090	201M112-19B	ADAPTER,CABLE CLAMP.....	1
12	PAFZZ	5935010268552	96906	MS3474L12-10S	CONNECTOR,RECEPTACL.....	1
13	PAFZZ		S7040	EPD-RWC-10654	CABLE.....	6
14	PAFZZ	5998014485108	S7040	AY6707895-0	CIRCUIT CARD ASSEM.....	1
15	PAFZZ	5998014512334	S7040	PC6707877-0	PRINTED WIRING BOAR.....	1
16	PAFZZ	5950012842876	81349	M21038/27-02	TRANSFORMER,PULSE.....	1
17	PAFZZ	5905012007320	81349	RWR81N56R2FS	RESISTOR,FIXED,WIRE.....	1
18	PAFZZ	5305000667325	96906	MS24693-C5	SCREW,MACHINE.....	3
19	PAFZZ	5305000545647	96906	MS51957-13	SCREW,MACHINE.....	2
20	PAFZZ	5940012216415	81349	SE11XC01S	TERMINAL,STUD.....	6
21	PAFZZ	5940002582106	98571	107022	TERMINAL,LUG.....	2
22	PAFZZ	5935014511305	S7040	MP6707874-0	ADAPTER,CONNECTOR.....	1
23	PAFZZ	5310009338118	96906	MS35338-135	WASHER,LOCK.....	2
24	PAFZZ	5935014511307	S7040	MP6707885-0	ADAPTER,CONNECTOR.....	1

END OF FIGURE



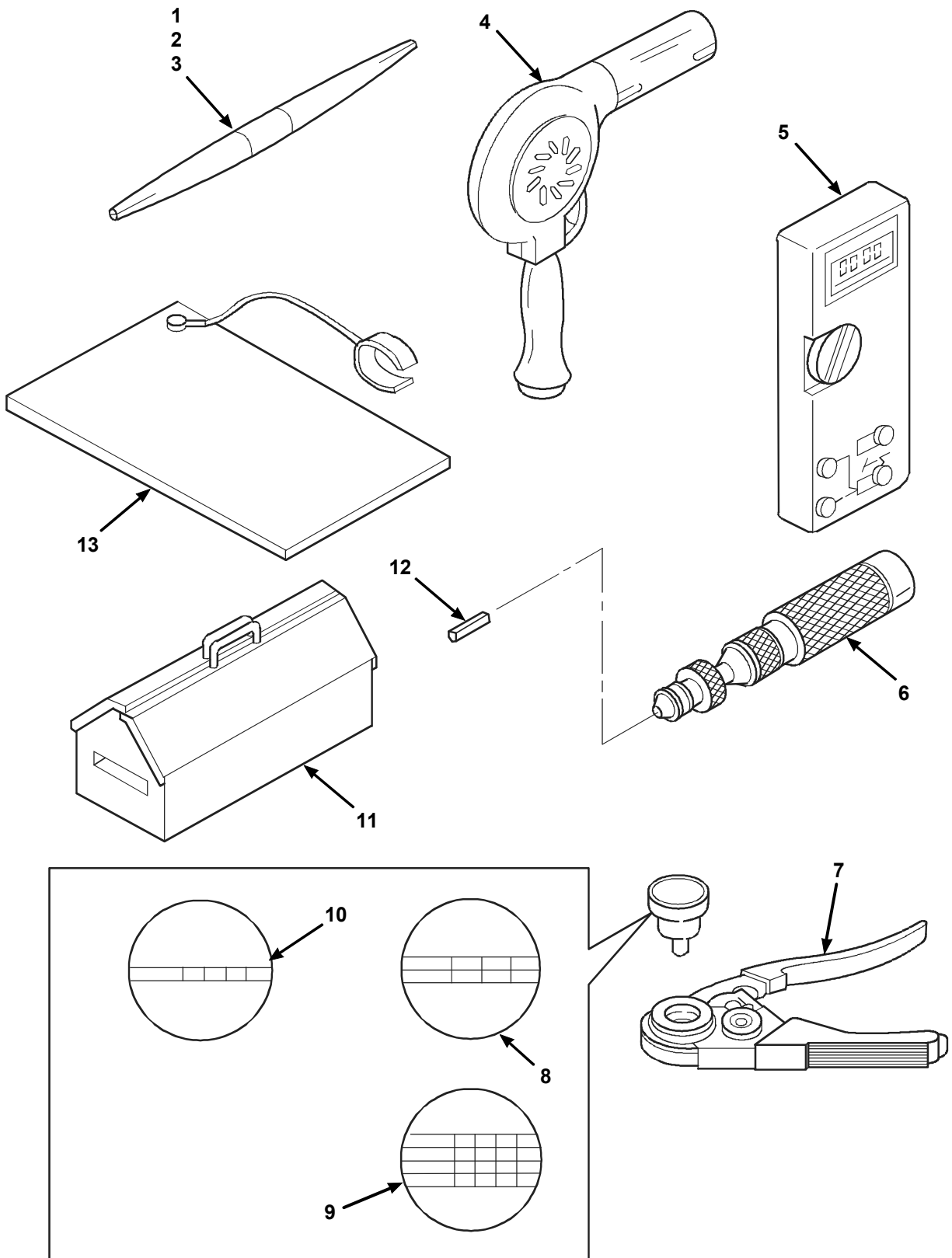

Figure C-11. Special Support Equipment (Sheet 1 of 2)

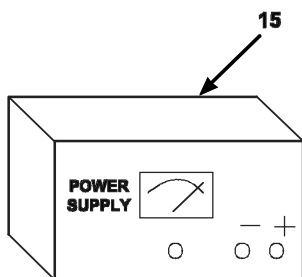
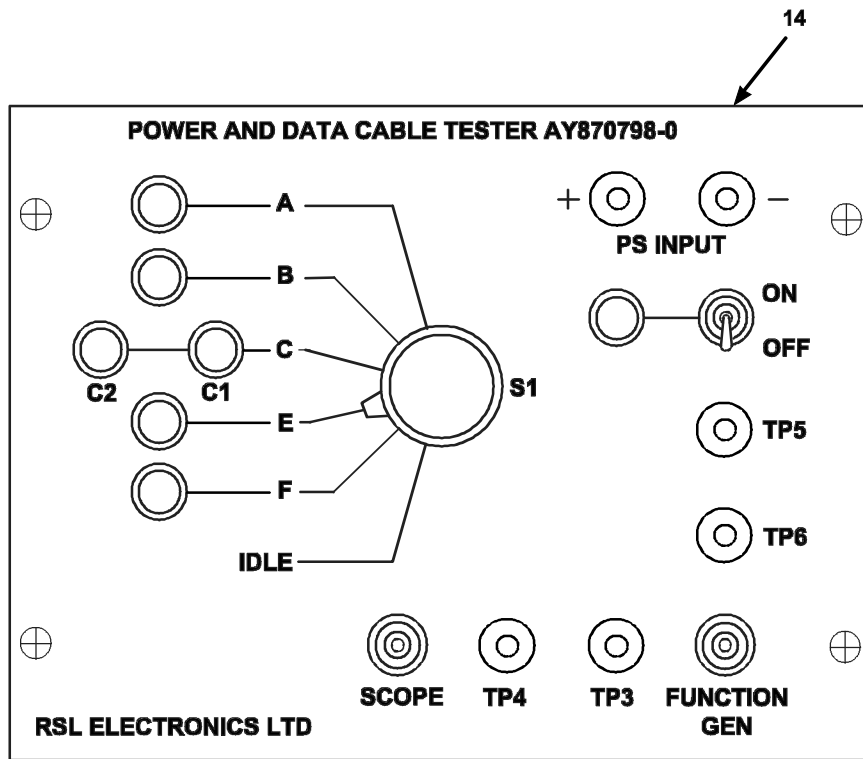

Figure C-11. Special Support Equipment (Sheet 2 of 2)



SECTION II		TM9-1290-365-24&P				
(1)	(2)	(3)	(4)	(5)	(6)	(7)
ITEM	SMR			PART		
NO	CODE	NSN	CAGEC	NUMBER	DESCRIPTION AND USABLE ON CODES (UOC)	QTY
FIG. C-11 SPECIAL SUPPORT EQUIPMENT						
1	PEFZZ	5120000180575	81349	M81969/14-01	INSERTER AND REMOVE INSTALLING AND REMOVAL TOOL.....	1
2	PEFZZ	5120009154587	81349	M81969/14-11	INSERTER AND REMOVE.....	1
3	PEFZZ	5120009154588	81349	M81969/14-03	INSERTER AND REMOVE.....	1
4	PEFZZ	4940012784142	83284	10008	HEAT GUN,ELECTRIC.....	1
5	PEFZZ	6625011686856	89536	77-2	MULTIMETER.....	1
6	PEFZZ	5120009318361	96508	TS30	WRENCH,TORQUE.....	1
7	PEFZZ	5120001653912	81349	M22520/1-01	CRIMPING TOOL,TERMI.....	1
8	PEFZZ	5120000167582	81349	M22520/1-04	TURRET HEAD,CRIMPIN.....	1
9	PEFZZ	5120001325039	81349	M22520/1-09	CONTACT POSITIONER,.....	1
10	PEFZZ	5120000166382	81349	M22520/1-02	TURRET HEAD,CRIMPIN.....	1
11	PEFZZ	5180006050079	80063	PPL863	TOOL KIT,ELECTRONIC.....	1
12	PEFZZ	5120013673497	55719	TMP12A	SCREWDRIVER ATTACHM.....	1
13	PEFZZ	4940012504236	81349	M87893-02	WORK STATION KIT,EL ESD.....	1
14	PEOZA	6150014461585	S7040	AY6707984-0	TESTER, CABLE,POWER.....	1
15	PEDZZ	6130014484889	80103	LLS-6040	POWER SUPPLY.....	1
16	XDFZZ		23338	178	GENERATOR,FUNCTION,.....	1
17	PEFZZ	6625014484891	28480	1070B	OSCILLOSCOPE.....	1
18	PEDZZ	5985007291297	99899	640	HORN,WAVEGUIDE.....	1
19	PEDZZ	6145014748333	S7040	WA6708171-0	CABLE,SPECIAL PURPO.....	1
20	PEDZZ	6130004770549	80103	LK342AFM	POWER SUPPLY.....	1
21	PEFZZ	5120013677652	50893	31335	WRENCH,STRAP.....	1
22	PADZZ	6145014748329	S7040	WA6708103-0	CABLE,SPECIAL PURPO.....	1
23	PDDZZ	7030014399539	S7040	RD6707416-0	DISK PROGRAM,AUTOMA.....	1
24	PEDZZ	6130013568001	80103	LLS-9040	POWER SUPPLY.....	1
25	PADZZ		S7804	OWA6707293-0	CABLE, ADAPTER.....	1
26	PEDZZ	6625012674887	28480	5350B	COUNTER,ELECTRONIC,.....	1
27	PEDZZ	6625014748332	S7040	AY6708004-0	TEST SET,ELECTRONIC.....	1
28	PEDZZ	6625014748334	S7040	AY6707046-0	TEST SET,ELECTRONIC.....	1
29	PADZZ	6145014748327	S7040	WA6708170-0	CABLE,SPECIAL PUPOS.....	1
30	PEDZZ		S7040	WA6708068-0	CABLE, TEST,TRANSCE.....	1
31	PADZZ	6145014748328	S7040	WA6708167-0	CABLE,SPECIAL PURPO.....	1
32	PEDZZ		29685	4M	ATTENUATOR.....	1
33	PEDZZ	6625014748330	S7040	AY6708172-0	TEST SET,ELECTRONIC.....	1
34	PADZZ	5950009314014	80249	890664	TRANSFORMER,AUDIO F.....	1
35	PEDZZ	5120011736247	26805	2098-0275-54	WRENCH,TORQUE.....	1
36	PEDZZ	6625011761269	89536	PM6680/011	COUNTER,ELECTRONIC,.....	1
37	PEDZZ	6625011719937	28480	3478A	MULTIMETER.....	1
38	PADZZ	6150014170902	S7040	WA6707296-0	CABLE ASSEMBLY,SPEC.....	1
39	PEDZZ	6625008688334	80058	ME-162/U	WATTMETER.....	1

END OF FIGURE

SECTION II			TM9-1290-365-24&P			
(1)	(2)	(3)	(4)	(5)	(6)	(7)
ITEM	SMR			PART		
NO	CODE	NSN	CAGEC	NUMBER	DESCRIPTION AND USABLE ON CODES (UOC)	QTY
					FIG. BULK	
					BULK MATERIALS	
1	PADZZ	8040009006296	81348	MMM-A-134	ADHESIVE.....	1
2	PAFZZ	8040001342172	81349	MMM-A-1931	ADHESIVE.....	1
3	PADZZ	7510008888527	81349	M43553-2WHTQT	INK, MARKING STENCIL.....	1
4	PADZZ	7510001450065	81349	M43553-IIBLKOZ	INK, MARKING STENCIL.....	1
5	PADZZ	5970013403255	01139	RTV3145	INSULATING COMPOUND.....	1
6	PADZZ	5970004420272	81349	MILI46058TYPE 1B 31	INSULATING VARNISH,.....	1
7	PAHZZ	5970008370647	81349	M22129-22-N	INSULATION SLEEVING.....	1
8	PADZA	5970009084200	06090	234A011-3	INSULATION SLEEVING.....	1
9	PADZZ	7530014462909	0FTJ9	DAT-59-652-1	LABEL.....	1
10	PADZZ	7530014461586	0FTJ9	DAT-50-652-1	LABEL.....	1
11	PADZZ		66579	WS27C256F-55DMB	MICROCIRCUIT, MEMORY.....	1
12	PADZZ		66579	WS27C256F-55DMB	MICROCIRCUIT, MEMORY.....	1
13	PADZZ		66759	WS27C256F-55DMB	MICROCIRCUIT, MEMORY.....	1
14	PADZZ	5962013726876	67268	5962-8867004LA	MICROCIRCUIT, MEMORY.....	1
15	PADZZ	5962012773331	81349	M38510/65702BCA	MICROCIRCUIT, DIGITA.....	1
16	PADZZ	5999010540593	58536	A-55485/02-004D	MOUNTING PAD, ELECTR.....	6
17	PADZZ	5999010153901	81349	M38527/01-030D	MOUNTING PAD, ELECTR.....	2
18	PADZZ	8010011412419	81349	MIL-C-46168	POLYURETHANE COATIN.....	1
19	PADZZ	8030000822508	05972	747-55	PRIMER, SEALING COMP.....	1
20	PCDZZ	8030000812330	05972	83-31	SEALING COMPOUND.....	1
21	PAFZZ	8030000812338	81349	MIL-S-22473	SEALING COMPOUND.....	1
22	PADZZ	6850002814033	01139	G641	SILICONE COMPOUND.....	1
23	PADZZ	3439013983036	81348	SN63WRMAP3	SOLDER, TIN ALLOY.....	1
24	PAFZZ	5940011357076	81349	M83519/1-1	SPLICE, CONDUCTOR.....	8
25	PADZZ		76381	75 1/4	TAPE.....	1
26	PADZZ		81349	MIL-T-43435T1S3F BBLK	TAPE, LACING AND TYI.....	1
27	PAFZZ	6145004811954	81349	M81044/12-20-0	WIRE, ELECTRICAL.....	1
28	PAFZZ	6145009394964	81349	M22759/11-20-9	WIRE, ELECTRICAL.....	1

END OF FIGURE

## CROSS-REFERENCE INDEXES

STOCK NUMBER	NATIONAL STOCK NUMBER INDEX		STOCK NUMBER	FIG.	ITEM
	FIG.	ITEM			
5910-00-010-8666	C5	4	5905-00-185-4094	C4	108
5910-00-010-8721	C4	17	5905-00-185-9131	C4	79
	C5	6	5905-00-185-9134	C4	103
5120-00-016-6382	C11	10	5905-00-189-0729	C4	110
5120-00-016-7582	C11	8	5905-00-189-0731	C4	85
5120-00-018-0575	C11	1	5310-00-208-3786	C3	5
5961-00-022-5669	C5	15		C4	161
5310-00-043-4708	C2	14		C7	78
	C7	71	5305-00-225-6400	C3	6
5305-00-054-5637	C2	12	5940-00-258-2106	C10	21
5305-00-054-5639	C7	77	5905-00-262-5271	C4	65
5305-00-054-5646	C2	30	5961-00-272-8333	C4	25
5305-00-054-5647	C2	21	6850-00-281-4033	BULK	22
	C6	7	5905-00-285-0616	C4	98
	C10	19	5905-00-285-0620	C4	71
5305-00-054-5648	C2	44	5905-00-285-1204	C4	59
	C4	159	5905-00-285-1310	C4	107
5305-00-054-5649	C2	6	5905-00-285-1401	C4	93
	C7	69	5910-00-305-9515	C5	11
5305-00-054-5652	C2	45	5905-00-306-1800	C4	99
5305-00-054-6669	C8	6	5905-00-320-6632	C4	97
5305-00-054-6670	C2	17	5961-00-324-3078	C4	33
5310-00-057-0573	C2	8	5905-00-335-7858	C4	66
	C4	160	5905-00-412-4049	C4	128
	C6	8	5905-00-421-2921	C4	135
5305-00-066-7325	C10	18	5970-00-442-0272	BULK	6
8030-00-081-2330	BULK	20	5905-00-443-9270	C4	138
8030-00-081-2338	BULK	21	5905-00-443-9370	C4	102
8030-00-082-2508	BULK	19	5905-00-444-5479	C4	56
5970-00-082-3942	C2	38	5961-00-458-6778	C4	32
5905-00-112-1308	C4	76	5905-00-468-3020	C4	130
5910-00-113-5284	C4	7	6130-00-477-0549	C11	20
5910-00-113-5286	C4	14	6145-00-481-1954	BULK	27
	C5	9	5935-00-490-3743	C2	39
5910-00-113-5465	C4	4	5935-00-490-5219	C2	24
	C5	7	5910-00-495-0042	C5	1
5910-00-113-5499	C4	1	5961-00-499-7249	C4	38
5910-00-113-5536	C4	55	5905-00-534-7164	C4	83
5905-00-121-9919	C7	32	5905-00-549-0919	C4	86
5120-00-132-5039	C11	9	5905-00-578-9983	C4	81
5910-00-143-0501	C4	5	5905-00-581-6461	C4	106
7510-00-145-0065	BULK	4	5905-00-581-6474	C4	80
5120-00-165-3912	C11	7	5961-00-584-4527	C4	22
5910-00-171-0018	C4	16		C5	12
5905-00-182-8100	C4	104		C7	10
5905-00-182-8101	C4	91	5310-00-595-6761	C2	46
5905-00-182-8102	C4	94	5180-00-605-0079	C11	11
5905-00-182-8103	C4	70	6145-00-669-6564	C7	79
5905-00-182-8104	C4	64	5940-00-682-2477	C2	31
5905-00-182-8105	C4	73		C6	5

## CROSS-REFERENCE INDEXES

STOCK NUMBER	NATIONAL STOCK NUMBER INDEX		STOCK NUMBER	FIG.	ITEM
	FIG.	ITEM			
5310-00-685-3744	C2	19	5999-01-015-3901	C7	76
5905-00-721-0815	C7	21		BULK	17
5310-00-723-9676	C3	3	5905-01-015-8085	C4	132
	C7	68	5961-01-017-0992	C4	24
5961-00-728-5309	C4	41	5905-01-017-2861	C4	111
5985-00-729-1297	C11	18	5961-01-019-4947	C4	49
5905-00-758-2925	C4	140	5905-01-019-9500	C4	113
5905-00-758-2947	C4	101	5905-01-023-8084	C4	62
5310-00-767-9425	C8	3	5905-01-023-8999	C4	60
5305-00-780-8454	C3	8	5935-01-026-8552	C10	12
5310-00-781-9483	C2	5	5905-01-036-7847	C4	95
5340-00-782-8737	C2	32	5905-01-036-8619	C4	77
5310-00-812-4294	C7	72	5961-01-037-4712	C4	35
5970-00-837-0647	BULK	7	5961-01-048-5636	C4	23
5305-00-855-2989	C2	1	5905-01-053-5789	C5	21
5961-00-858-3826	C4	48		C7	22
	C7	17	5999-01-054-0593	C7	73
6625-00-868-8334	C11	39		BULK	16
5970-00-871-5779	C9	7	5961-01-055-2232	C4	21
5310-00-880-5975	C8	8	5961-01-058-6633	C4	40
7510-00-888-8527	BULK	3	5961-01-064-4876	C4	37
8040-00-900-6296	BULK	1	5905-01-067-4888	C4	67
5970-00-908-4200	BULK	8	5961-01-068-1652	C4	26
5120-00-915-4587	C11	2	5961-01-070-8942	C7	12
5120-00-915-4588	C11	3	5935-01-071-5291	C4	44
5970-00-923-7173	C10	6	5935-01-074-3386	C7	14
5310-00-928-2690	C2	13	5905-01-080-1502	C4	68
	C7	70	5905-01-080-1503	C4	63
5950-00-931-4014	C11	34	5905-01-080-1512	C4	61
5310-00-933-8118	C2	7	5905-01-082-4272	C4	134
	C3	4	5905-01-085-1164	C7	24
	C4	162	5961-01-087-9430	C4	31
	C7	80	5962-01-087-9496	C4	153
	C10	23	5961-01-096-3192	C4	36
5310-00-933-8119	C2	18	5961-01-105-0607	C4	27
	C8	7	5961-01-105-0608	C5	13
5310-00-933-8120	C2	4	5935-01-107-8811	C9	6
5310-00-933-8121	C1	7	5910-01-119-4310	C4	19
5310-00-933-8778	C8	2	5910-01-119-4313	C4	15
6145-00-939-4955	C2	34	5935-01-122-7585	C9	1
6145-00-939-4964	BULK	28	5962-01-123-3186	C7	43
6145-00-948-9479	C2-2	36		C7	44
5305-00-959-0379	C2	48	5910-01-126-2071	C4	2
5342-00-985-0248	C8	5	5962-01-126-3888	C4	155
5305-00-993-9189	C2	47	5905-01-127-6299	C4	78
5905-01-006-0078	C4	87	5905-01-127-6300	C4	89
5905-01-006-8517	C4	92	5905-01-127-6301	C4	72
5961-01-009-6320	C4	28	5905-01-133-0534	C4	84
5905-01-012-3748	C4	69	6145-01-135-6836	C2	33
5999-01-015-3901	C4	166	5940-01-135-7076	BULK	24

## CROSS-REFERENCE INDEXES

STOCK NUMBER	NATIONAL STOCK NUMBER INDEX		STOCK NUMBER	FIG.	ITEM
	FIG.	ITEM			
5940-01-135-7077	C2	35	5910-01-171-8690	C4	13
5940-01-136-2540	C2	37	5910-01-171-8692	C4	10
5962-01-136-4640	C4	154	5910-01-171-8693	C4	8
5935-01-136-8097	C7	15		C7	1
5905-01-137-0094	C7	29	6625-01-171-9937	C11	37
5905-01-137-0108	C5	20	5120-01-173-6247	C11	35
5905-01-137-0109	C5	30	5905-01-173-8932	C4	124
5935-01-137-9041	C7	13	5905-01-174-8473	C4	114
5905-01-138-6261	C5	22	5905-01-175-7856	C4	53
5905-01-139-5314	C5	25	6625-01-176-1269	C11	36
	C7	26	5905-01-176-3870	C4	50
5905-01-139-5316	C5	19	5905-01-176-7343	C4	133
	C7	28	5905-01-176-7346	C4	143
5905-01-140-5573	C4	116	5961-01-179-3470	C5	16
8010-01-141-2419	BULK	18	5935-01-179-3497	C2	25
5910-01-141-5549	C4	9	5962-01-182-0577	C7	53
5310-01-141-6672	C2	22	5905-01-183-6168	C7	25
5905-01-146-4349	C5	33	5905-01-185-1319	C4	125
5905-01-146-6671	C5	18	5905-01-186-3783	C4	115
5905-01-146-6673	C5	28	5905-01-186-4912	C4	117
5935-01-147-5741	C6	1	5905-01-186-6677	C4	136
5905-01-148-6092	C5	29	5905-01-186-7774	C4	57
5905-01-149-1143	C5	27		C4	121
	C7	27	5905-01-187-1636	C4	139
5905-01-150-5459	C7	33	5961-01-187-8836	C5	17
5905-01-150-5515	C7	30		C7	16
5905-01-151-1187	C7	18	5962-01-189-4489	C7	55
5905-01-155-1563	C4	100	5961-01-196-9452	C4	47
5980-01-159-0947	C4	43	5905-01-200-7320	C10	17
5905-01-160-0032	C7	19	5962-01-200-8321	C7	41
5905-01-160-0932	C7	23	5905-01-202-5861	C4	120
5340-01-160-2304	C2	20	5910-01-207-6979	C4	3
5962-01-160-4990	C4	156	5905-01-209-6528	C7	35
	C7	60	5910-01-212-7847	C7	5
5905-01-162-0729	C7	34	5905-01-213-4134	C4	122
5905-01-162-0731	C5	26	5910-01-214-1009	C7	6
5905-01-165-9845	C5	24	5910-01-215-4597	C5	10
5905-01-167-6969	C7	31	5910-01-217-8875	C5	8
5905-01-168-6520	C4	141	5940-01-221-6415	C5	35
6625-01-168-6856	C11	5		C10	20
5905-01-168-7801	C7	20	5910-01-221-9889	C7	9
5905-01-169-0036	C4	142	5970-01-223-1416	C4	165
5905-01-169-0047	C4	118	5935-01-223-9820	C9	5
5905-01-169-4098	C5	23		C10	11
5905-01-170-0376	C4	137	5910-01-224-3023	C7	2
5905-01-170-0380	C4	51	5910-01-226-4614	C7	7
5905-01-170-0388	C4	127	5910-01-233-0730	C5	3
5905-01-170-9062	C4	54	5910-01-234-1523	C4	11
5962-01-171-3774	C7	42	5910-01-238-0381	C5	2
5910-01-171-6524	C7	8	5961-01-239-0829	C4	34

## CROSS-REFERENCE INDEXES

STOCK NUMBER	NATIONAL STOCK NUMBER INDEX		STOCK NUMBER	FIG.	ITEM
	FIG.	ITEM			
5910-01-239-3994	C5	5	5935-01-435-4414	C1	2
5905-01-244-4465	C4	126	6130-01-435-4417	C2	10
5910-01-245-6446	C7	3	5998-01-435-9715	C3	1
4940-01-250-4236	C11	13	7030-01-439-9539	C11	23
5962-01-254-1149	C7	38	5340-01-440-5938	C1	3
5935-01-261-1503	C10	3	5840-01-442-6197	C4	151
5905-01-261-3758	C4	131	5330-01-442-6611	C2	9
5910-01-265-7630	C5	34	5365-01-442-8174	C3	2
5905-01-266-8951	C4	129	5365-01-443-5130	C3	9
6625-01-267-4887	C11	26	5930-01-444-4571	C7	82
5910-01-271-0897	C4	18	5905-01-445-5923	C4	119
	C7	4	6150-01-446-1585	C11	14
5962-01-272-4446	C7	39	7530-01-446-1586	BULK	10
5962-01-277-3331	C7	50	9905-01-446-1594	C2	5A
	BULK	15	6150-01-446-1595	C1	4
4940-01-278-4142	C11	4	5306-01-446-1596	C8	1
5905-01-279-4826	C7	61	7530-01-446-2909	BULK	9
5935-01-279-8630	C2	2	5840-01-446-4156	C2	16
5962-01-280-3480	C7	56	5961-01-446-4255	C4	46
5962-01-282-1049	C7	40	5935-01-446-5272	C7	81
5950-01-284-2876	C7	36	5935-01-447-2744	C6	2
	C10	16	5935-01-447-2752	C2	43
5962-01-286-2238	C7	51	5950-01-447-8128	C4	42
5962-01-287-9492	C5	32	5950-01-447-8132	C4	146
5962-01-289-7408	C4	152	5950-01-447-8133	C4	144
5975-01-291-6323	C9	3	5950-01-447-8134	C4	148
	C10	9	5950-01-447-8136	C4	147
5935-01-321-8932	C4	45	5340-01-447-8669	C2	49
5910-01-331-8610	C4	20	5970-01-447-9867	C4	167
5910-01-333-4896	C4	6	6130-01-448-4889	C11	15
5970-01-340-3255	BULK	5	6625-01-448-4891	C11	17
5970-01-355-5982	C9	8	5365-01-448-5081	C2	41
6130-01-356-8001	C11	24	5998-01-448-5108	C10	14
5120-01-367-3497	C11	12	5915-01-448-9399	C2	40
5120-01-367-7652	C11	21	5935-01-448-9752	C7	74
5962-01-372-3606	C7	58	5999-01-448-9825	C4	164
5962-01-372-6876	BULK	14	5640-01-449-1938	C7	67
5905-01-375-0573	C7	62	5340-01-450-1988	C10	5
5970-01-376-5868	C10	10	5935-01-450-3063	C10	7
5961-01-381-7429	C4	30	1290-01-450-3467	C2	50
5975-01-385-8686	C10	1	5935-01-450-3707	C10	4
5905-01-388-8231	C4	123	5935-01-451-1305	C10	22
5962-01-394-3454	C7	63	5935-01-451-1307	C10	24
3439-01-398-3036	BULK	23	5998-01-451-2334	C10	15
5962-01-406-2375	C7	45	5935-01-459-6068	C10	2
6150-01-417-0902	C11	38	5970-01-464-0254	C7	75
5895-01-417-7101	C1	1	6145-01-474-8327	C11	29
5962-01-420-8941	C7	59	6145-01-474-8328	C11	31
5998-01-435-3129	C2	15	6145-01-474-8329	C11	22
5998-01-435-3132	C2	42	6625-01-474-8330	C11	33

## CROSS-REFERENCE INDEXES

STOCK NUMBER	NATIONAL STOCK NUMBER INDEX		FIG.	ITEM
	FIG.	ITEM		
5935-01-474-8331	C10	8		
6625-01-474-8332	C11	27		
6145-01-474-8333	C11	19		
6625-01-474-8334	C11	28		
6150-01-475-4290	C1	5		
5305-12-189-7984	C1	6		

## CROSS-REFERENCE INDEXES

CAGEC	PART NUMBER INDEX		FIG.	ITEM
	PART NUMBER	STOCK NUMBER		
58536	A-55485/02-004D	5999-01-054-0593	C7	73
			BULK	16
51640	ADSP-2100ASG/883	5962-01-394-3454	C7	63
	B			
S7040	AM6707435-0		C4	158
S7040	AM6707834-0		C2	27
S7040	AM6708191-0		C6	3
88044	AN960C4	5310-01-141-6672	C2	22
88041	AN960C8	5310-00-685-3744	C2	19
S7040	AY67010314		C2	42
S7040	AY67010553	1290-01-450-3467	C2	50
S7040	AY6706557-0	5840-01-446-4156	C2	16
S7040	AY6706566-0	5998-01-435-3129	C2	15
S7040	AY6707046-0	6625-01-474-8334	C11	28
S7040	AY67010314	5998-01-435-3132	C2	42
S7040	AY6707289-1	5915-01-448-9399	C2	40
S7040	AY6707290-0	5998-01-435-9715	C3	1
S7040	AY6707291-0	6130-01-435-4417	C2	10
S7040	AY6707895-0	5998-01-448-5108	C10	14
S7040	AY6707984-0	6150-01-446-1585	C11	14
S7040	AY6708004-0	6625-01-474-8332	C11	27
S7040	AY6708172-0	6625-01-474-8330	C11	33
S7040	AY6708194-0		C6	4
81349	CCR05CG101FS	5910-01-215-4597	C5	10
81349	CCR05CG681FS	5910-01-214-1009	C7	6
81349	CCR05CJ4R7BS	5910-01-238-0381	C5	2
81349	CCR05CJ6R8BS	5910-01-221-9889	C7	9
02598	CT2577-10-QM-P11		C7	52
	9			
OFTJ9	DAT-50-652-1	7530-01-446-1586	BULK	10
OFTJ9	DAT-59-652-1	7530-01-446-2909	BULK	9
D8286	DIN912-M6X40-12.9-B2P	5305-12-189-7984	C1	6
81349	D38999/24WC98PN	5935-01-147-5741	C6	1
81349	D38999/26WC98SN	5935-01-122-7585	C9	1
81349	D38999/33W13N	5935-01-279-8630	C2	2
81349	D38999/46WD97SD	5935-01-450-3063	C10	7
81349	D38999/46WF32PA	5935-01-261-1503	C10	3
81349	D38999/49WD97PD	5935-01-450-3707	C10	4
S7040	EA6706148-0		C2	26
S7040	EPD-RWC-10654		C9	4
			C10	13
01139	G641	6850-00-281-4033	BULK	22
59993	IRFY140	5961-01-446-4255	C4	46
81349	JANTXV2N2907A	5961-01-019-4947	C4	49
81349	JANTX1N4106	5961-01-017-0992	C4	24
81349	JANTX1N4148-1	5961-00-584-4527	C4	22
			C5	12
			C7	10
81349	JANTX1N4469	5961-00-324-3078	C4	33
81349	JANTX1N4471	5961-00-728-5309	C4	41



## CROSS-REFERENCE INDEXES

CAGEC	PART NUMBER	PART NUMBER INDEX STOCK NUMBER	FIG.	ITEM
81349	JANTX1N4474	5961-01-087-9430	C4	31
81349	JANTX1N4475	5961-01-096-3192	C4	36
81349	JANTX1N4478	5961-01-009-6320	C4	28
81349	JANTX1N4573A	5961-01-048-5636	C4	23
81349	JANTX1N4961	5961-00-272-8333	C4	25
81349	JANTX1N4964	5961-00-458-6778	C4	32
81349	JANTX1N4965	5961-00-499-7249	C4	38
81349	JANTX1N5311	5961-01-068-1652	C4	26
81349	JANTX1N5420	5961-01-055-2232	C4	21
81349	JANTX1N5806	5961-01-037-4712	C4	35
81349	JANTX1N5811	5961-01-058-6633	C4	40
81349	JANTX1N5969	5961-01-239-0829	C4	34
81349	JANTX1N6064A		C4	39
81349	JANTX1N6621	5961-01-381-7429	C4	30
81349	JANTX1N750A-1	5961-01-105-0607	C4	27
81349	JANTX1N756A		C7	11
81349	JANTX1N758A-1	5961-01-070-8942	C7	12
81349	JANTX1N965B-1	5961-01-105-0608	C5	13
81349	JANTX1N966B-1	5961-01-064-4876	C4	37
81349	JANTX2N2219AL	5961-01-179-3470	C5	16
81349	JANTX2N2222A	5961-00-858-3826	C4	48
			C7	17
81349	JANTX2N2905AL	5961-01-187-8836	C5	17
			C7	16
81349	JANTX2N6796	5961-01-196-9452	C4	47
81349	JANTX2N930	5961-00-022-5669	C5	15
81349	JANTX4N49	5980-01-159-0947	C4	43
80103	LK342AFM	6130-00-477-0549	C11	20
80103	LLS-6040	6130-01-448-4889	C11	15
80103	LLS-9040	6130-01-356-8001	C11	24
64155	LM136AH-2.5/883	5962-01-160-4990	C7	60
27014	LM136AH-2.5/883B	5962-01-160-4990	C4	156
27014	LM158AJ/883C	5962-01-126-3888	C4	155
S7040	MC6707417-0		C7	54
S7040	MC6707418-0		C7	48
S7040	MC6707419-0		C7	47
S7040	MC6707420-0		C7	46
34371	MD82C54/B	5962-01-280-3480	C7	56
34649	MD8215A/B		C7	57
80058	ME-162/U	6625-00-868-8334	C11	39
81349	MIL-C-46168	8010-01-141-2419	BULK	18
81349	MIL-S-22473	8030-00-081-2338	BULK	21
81349	MIL-T-43435T1S3F		BULK	26
	BBLK			
81349	MILI46058TYPE 1B	5970-00-442-0272	BULK	6
	31			
81348	MMM-A-134	8040-00-900-6296	BULK	1
81349	MMM-A-1931		BULK	2
27014	MM54C244J-MIL	5962-01-123-3186	C7	43
			C7	44
27014	MM54HC08J/883B	5962-01-200-8321	C7	41

## CROSS-REFERENCE INDEXES

CAGEC	PART NUMBER	PART NUMBER INDEX		FIG.	ITEM
			STOCK NUMBER		
04713	MM54HC164/BCAJC			C7	64
27014	MM54HC273J/883B		5962-01-282-1049	C7	40
27014	MM54HC32J/883B		5962-01-171-3774	C7	42
S7040	MP6706562-0			C2	3
S7040	MP6706569-0			C2	11
S7040	MP6706570-0		5330-01-442-6611	C2	9
S7040	MP6706581-0		5970-01-447-9867	C4	167
S7040	MP6706582-0			C7	66
S7040	MP6706583-0		5640-01-449-1938	C7	67
S7040	MP6706605-0		5365-01-442-8174	C3	2
S7040	MP6706606-0			C4	163
S7040	MP6706607-0		5365-01-443-5130	C3	9
S7040	MP6706616-0		5999-01-448-9825	C4	164
S7040	MP6706700-1			C6	6
S7040	MP6707423-0			C3	7
S7040	MP6707844-0		5935-01-446-5272	C7	81
S7040	MP6707852-0		5365-01-448-5081	C2	41
S7040	MP6707874-0		5935-01-451-1305	C10	22
S7040	MP6707885-0		5935-01-451-1307	C10	24
S7040	MP6708090-0			C2	29
S7040	MP6708199-0		5340-01-447-8669	C2	49
96906	MS15795-802		5310-00-595-6761	C2	46
96906	MS15795-818		5310-00-767-9425	C8	3
96906	MS16995-10		5305-00-959-0379	C2	48
96906	MS21919WCG2		5340-01-160-2304	C2	20
96906	MS24693-C2		5305-00-993-9189	C2	47
96906	MS24693-C3		5305-00-225-6400	C3	6
96906	MS24693-C5		5305-00-066-7325	C10	18
96906	MS24693-C7		5305-00-780-8454	C3	8
96906	MS3212-31		5305-00-855-2989	C2	1
96906	MS3474L12-10S		5935-01-026-8552	C10	12
96906	MS3476W12-10P		5935-01-107-8811	C9	6
96906	MS35338-134		5310-00-928-2690	C2	13
				C7	70
96906	MS35338-135		5310-00-933-8118	C2	7
				C3	4
				C4	162
				C7	80
				C10	23
96906	MS35338-137		5310-00-933-8119	C2	18
				C8	7
96906	MS35338-138		5310-00-933-8120	C2	4
96906	MS35338-139		5310-00-933-8121	C1	7
96906	MS35338-143		5310-00-933-8778	C8	2
96906	MS51957-12		5305-00-054-5646	C2	30
96906	MS51957-13		5305-00-054-5647	C2	21
				C6	7
				C10	19
96906	MS51957-14		5305-00-054-5648	C2	44
				C4	159
96906	MS51957-15		5305-00-054-5649	C2	6

## CROSS-REFERENCE INDEXES

CAGEC	PART NUMBER	PART NUMBER INDEX		FIG.	ITEM
			STOCK NUMBER		
96906	MS51957-15		5305-00-054-5649	C7	69
96906	MS51957-18		5305-00-054-5652	C2	45
96906	MS51957-3		5305-00-054-5637	C2	12
96906	MS51957-44		5305-00-054-6669	C8	6
96906	MS51957-45		5305-00-054-6670	C2	17
96906	MS51957-5		5305-00-054-5639	C7	77
96906	MS77068-1		5940-00-682-2477	C2	31
				C6	5
81349	M21038/27-02		5950-01-284-2876	C7	36
				C10	16
81349	M22129-22-N		5970-00-837-0647	BULK	7
81349	M22520/1-01		5120-00-165-3912	C11	7
81349	M22520/1-02		5120-00-016-6382	C11	10
81349	M22520/1-04		5120-00-016-7582	C11	8
81349	M22520/1-09		5120-00-132-5039	C11	9
81349	M22759/11-20-0		6145-00-939-4955	C2	34
81349	M22759/11-20-9		6145-00-939-4964	BULK	28
81349	M22759/11-24-9		6145-00-948-9479	C2-2	36
81349	M23053/5-105-9		5970-00-082-3942	C2	38
81349	M23053/5-208-C		5970-00-871-5779	C9	7
81349	M24308/2-1		5935-00-490-5219	C2	24
81349	M24308/23-8F		5935-01-321-8932	C4	45
81349	M24308/24-7		5935-01-071-5291	C4	44
81349	M24308/25-9		5935-01-179-3497	C2	25
81349	M24308/4-2		5935-00-490-3743	C2	39
81349	M27500-22SB2T23		6145-01-135-6836	C2	33
81349	M38510/10107BGA		5962-01-287-9492	C5	32
81349	M38510/10708BYC		5962-01-087-9496	C4	153
81349	M38510/11201BCA		5962-01-286-2238	C7	51
81349	M38510/65701BCA		5962-01-254-1149	C7	38
81349	M38510/65702BCA		5962-01-277-3331	C7	50
				BULK	15
81349	M38510/65802BEA		5962-01-272-4446	C7	39
81349	M38527/01-030D		5999-01-015-3901	C4	166
				C7	76
				BULK	17
81349	M39003-01-3076		5910-00-495-0042	C5	1
81349	M39003/01-8032		5910-01-245-6446	C7	3
81349	M39003/01-8078		5910-01-239-3994	C5	5
81349	M39003/01-8121		5910-01-233-0730	C5	3
81349	M39003/01-8214		5910-01-224-3023	C7	2
81349	M39003/03-3025		5910-01-271-0897	C4	18
				C7	4
81349	M39006/22-0528		5910-01-234-1523	C4	11
81349	M39006/22-0531		5910-01-126-2071	C4	2
81349	M39006/22-0545		5910-01-119-4310	C4	19
81349	M39006/22-0660		5910-01-119-4313	C4	15
81349	M39006/25-0222		5910-01-331-8610	C4	20
81349	M39014/01-1357		5910-00-010-8666	C5	4
81349	M39014/01-1583		5910-00-305-9515	C5	11
81349	M39014/02-1332		5910-00-143-0501	C4	5

## CROSS-REFERENCE INDEXES

CAGEC	PART NUMBER	PART NUMBER INDEX		FIG.	ITEM
			STOCK NUMBER		
81349	M39014/02-1349		5910-00-171-0018	C4	16
81349	M39014/02-1350		5910-00-113-5499	C4	1
81349	M39014/02-1355		5910-00-113-5536	C4	55
81349	M39014/02-1355V		5910-01-333-4896	C4	6
81349	M39014/02-1356		5910-00-113-5286	C4	14
				C5	9
81349	M39014/02-1358		5910-00-113-5284	C4	7
81349	M39014/02-1360		5910-00-113-5465	C4	4
				C5	7
81349	M39014/02-1419		5910-00-010-8721	C4	17
				C5	6
81349	M39014/22-0973		5910-01-207-6979	C4	3
81349	M39014/22-0975		5910-01-226-4614	C7	7
81349	M39014/22-0986		5910-01-171-8690	C4	13
81349	M39014/22-1011		5910-01-171-6524	C7	8
81349	M39014/22-1058		5910-01-141-5549	C4	9
81349	M39014/22-1060			C4	12
81349	M39014/22-1076		5910-01-171-8692	C4	10
81349	M39014/22-1079		5910-01-212-7847	C7	5
81349	M39014/22-1094		5910-01-171-8693	C4	8
				C7	1
81349	M43553-IIBLKOZ		7510-00-145-0065	BULK	4
81349	M43553-2WHTQT		7510-00-888-8527	BULK	3
81349	M55302/61-B14		5935-01-136-8097	C7	15
81349	M55302/61-B26		5935-01-137-9041	C7	13
81349	M55302/64-B60F		5935-01-074-3386	C7	14
81349	M55302/66L14H		5935-01-447-2744	C6	2
81349	M55302/66L26H		5935-01-447-2752	C2	43
81349	M55310/16-B41A32			C7	49
	M000				
81349	M81044/12-20-0		6145-00-481-1954	BULK	27
81349	M81969/14-01		5120-00-018-0575	C11	1
81349	M81969/14-03		5120-00-915-4588	C11	3
81349	M81969/14-11		5120-00-915-4587	C11	2
81349	M8340109K2211FC		5905-01-375-0573	C7	62
81349	M8340109K5601GC		5905-01-279-4826	C7	61
81349	M83421/01-4039S		5910-01-265-7630	C5	34
81349	M83421/01-4051S		5910-01-217-8875	C5	8
81349	M83519/1-1		5940-01-135-7076	BULK	24
81349	M83519/1-2		5940-01-136-2540	C2	37
81349	M83519/1-3		5940-01-135-7077	C2	35
81349	M87893-02		4940-01-250-4236	C11	13
80205	NAS1397P4N		5340-00-782-8737	C2	32
80205	NAS620C10L		5310-00-781-9483	C2	5
80205	NAS620C2		5310-00-043-4708	C2	14
				C7	71
80205	NAS620C4		5310-00-057-0573	C2	8
				C4	160
				C6	8
80205	NAS620C4L		5310-00-723-9676	C3	3
				C7	68

## CROSS-REFERENCE INDEXES

CAGEC	PART NUMBER	PART NUMBER INDEX		FIG.	ITEM
			STOCK NUMBER		
80205	NAS671C2		5310-00-812-4294	C7	72
80205	NAS671C4		5310-00-208-3786	C3	5
				C4	161
				C7	78
S7040	NP6707412-0			C2	28
24355	OP221AZ/883B	5840-01-442-6197		C4	151
S7040	PC6706565-0			C5	36
S7040	PC6707306-0			C4	157
S7040	PC6707307-0			C7	65
S7040	PC6707877-0	5998-01-451-2334		C10	15
89536	PM6680/011	6625-01-176-1269		C11	36
80063	PPL863	5180-00-605-0079		C11	11
91506	PPS101-1A1321L	5935-01-448-9752		C7	74
81348	QQW343S22S1B	6145-00-669-6564		C7	79
81349	RCR07G106JS	5905-00-121-9919		C7	32
S7040	RD6707416-0	7030-01-439-9539		C11	23
81349	REW620C8L	5310-00-880-5975		C8	8
81349	RLR05C10R0GS	5905-01-202-5861		C4	120
81349	RLR05C1001FS	5905-01-015-8085		C4	132
81349	RLR05C1002FS	5905-01-170-0380		C4	51
81349	RLR05C1003FS	5905-01-169-0047		C4	118
81349	RLR05C1004FR			C4	52
81349	RLR05C1241FS	5905-01-266-8951		C4	129
81349	RLR05C1620FS			C4	75
81349	RLR05C20R0FS	5905-01-168-6520		C4	141
81349	RLR05C2491FS	5905-01-186-7774		C4	57
				C4	121
81349	RLR05C2492FS	5905-01-170-0388		C4	127
81349	RLR05C2551FS	5905-01-261-3758		C4	131
81349	RLR05C3651FS	5905-01-170-9062		C4	54
81349	RLR05C4022FS	5905-01-186-6677		C4	136
81349	RLR05C47R0GS	5905-01-176-7343		C4	133
81349	RLR05C4701GS	5905-01-173-8932		C4	124
81349	RLR05C4702GS	5905-01-176-3870		C4	50
81349	RLR05C4750FS	5905-01-185-1319		C4	125
81349	RLR05C4751FS	5905-01-186-3783		C4	115
81349	RLR05C4752FS	5905-01-186-4912		C4	117
81349	RLR05C4753FR	5905-01-445-5923		C4	119
81349	RLR05C4991FS	5905-01-175-7856		C4	53
81349	RLR05C5R10GS	5905-01-244-4465		C4	126
81349	RLR05C56R2FS	5905-01-187-1636		C4	139
81349	RLR05C6200GS	5905-01-176-7346		C4	143
81349	RLR05C7502GS	5905-01-213-4134		C4	122
81349	RLR05C8251FS	5905-01-170-0376		C4	137
81349	RLR07C1001GS	5905-01-085-1164		C7	24
81349	RLR07C1002GS	5905-01-139-5314		C5	25
				C7	26
81349	RLR07C1003GS	5905-01-151-1187		C7	18
81349	RLR07C1201GS	5905-01-053-5789		C5	21
				C7	22
81349	RLR07C15R0GS	5905-01-169-4098		C5	23

## CROSS-REFERENCE INDEXES

CAGEC	PART NUMBER	PART NUMBER INDEX		FIG.	ITEM
			STOCK NUMBER		
81349	RLR07C1501GS		5905-01-148-6092	C5	29
81349	RLR07C1502GS		5905-01-146-6671	C5	18
81349	RLR07C1601GS		5905-01-167-6969	C7	31
81349	RLR07C1802GS		5905-01-146-6673	C5	28
81349	RLR07C20R0GS		5905-01-183-6168	C7	25
81349	RLR07C2001GS		5905-01-150-5459	C7	33
81349	RLR07C2003GS		5905-01-150-5515	C7	30
81349	RLR07C2203GS		5905-01-139-5316	C5	19
				C7	28
81349	RLR07C2401GS		5905-01-160-0032	C7	19
81349	RLR07C2700GS		5905-01-137-0108	C5	20
81349	RLR07C2702GS		5905-01-162-0731	C5	26
81349	RLR07C3301GS		5905-01-138-6261	C5	22
81349	RLR07C3572FS		5905-01-209-6528	C7	35
81349	RLR07C3900GS		5905-01-160-0932	C7	23
81349	RLR07C4301GS		5905-01-168-7801	C7	20
81349	RLR07C4702GS		5905-01-137-0109	C5	30
81349	RLR07C5601GS		5905-01-149-1143	C5	27
				C7	27
81349	RLR07C6800GS		5905-01-137-0094	C7	29
81349	RLR07C6801GS		5905-01-165-9845	C5	24
81349	RLR07C8201GS		5905-01-162-0729	C7	34
81349	RLR07C8202GS		5905-01-146-4349	C5	33
81349	RNC50H1000FS		5905-00-421-2921	C4	135
81349	RNC50H1002FS		5905-00-444-5479	C4	56
81349	RNC50H2001FS		5905-00-443-9270	C4	138
81349	RNC50H2002FS		5905-00-758-2925	C4	140
81349	RNC50J1101FS		5905-00-578-9983	C4	81
81349	RNC50J1401FS		5905-01-127-6299	C4	78
81349	RNC50J1402FS		5905-00-185-9131	C4	79
81349	RNC50J1431FS			C4	82
81349	RNC50J1432FS		5905-00-581-6474	C4	80
81349	RNC50J1471FS		5905-01-133-0534	C4	84
81349	RNC50J1501FS		5905-00-285-1310	C4	107
81349	RNC50J1502FS		5905-00-443-9370	C4	102
81349	RNC50J1541FS		5905-00-185-9134	C4	103
81349	RNC50J1542FS		5905-00-182-8100	C4	104
81349	RNC50J1581FS			C4	105
81349	RNC50J1582FS		5905-00-581-6461	C4	106
81349	RNC50J1621FS		5905-01-155-1563	C4	100
81349	RNC50J1622FS		5905-00-758-2947	C4	101
81349	RNC50J1651FS			C4	109
81349	RNC50J1652FS		5905-00-189-0729	C4	110
81349	RNC50J1691FS		5905-01-017-2861	C4	111
81349	RNC50J1692FS			C4	112
81349	RNC50J1741FS		5905-01-019-9500	C4	113
81349	RNC50J1742FS		5905-00-185-4094	C4	108
81349	RNC50J1781FS		5905-00-285-1401	C4	93
81349	RNC50J1782FS		5905-01-006-8517	C4	92
81349	RNC50J1821FS		5905-00-306-1800	C4	99
81349	RNC50J1822FS		5905-01-006-0078	C4	87

## CROSS-REFERENCE INDEXES

CAGEC	PART NUMBER	PART NUMBER INDEX		FIG.	ITEM
			STOCK NUMBER		
81349	RNC50J1871FS			C4	88
81349	RNC50J1872FS		5905-01-127-6300	C4	89
81349	RNC50J1911FS			C4	90
81349	RNC50J1912FS		5905-00-182-8101	C4	91
81349	RNC50J1961FS		5905-00-189-0731	C4	85
81349	RNC50J1962FS		5905-00-549-0919	C4	86
81349	RNC50J2001FS		5905-00-182-8102	C4	94
81349	RNC50J2002FR			C4	58
81349	RNC50J2051FS		5905-01-036-7847	C4	95
81349	RNC50J2052FS		5905-00-285-1204	C4	59
81349	RNC50J2101FS			C4	96
81349	RNC50J2102FS		5905-01-080-1502	C4	68
81349	RNC50J2151FS		5905-00-320-6632	C4	97
81349	RNC50J2152FS		5905-01-012-3748	C4	69
81349	RNC50J2211FS		5905-00-285-0616	C4	98
81349	RNC50J2212FS		5905-00-285-0620	C4	71
81349	RNC50J2261FS		5905-01-036-8619	C4	77
81349	RNC50J2262FS		5905-01-127-6301	C4	72
81349	RNC50J2321FS		5905-00-534-7164	C4	83
81349	RNC50J2322FS			C4	74
81349	RNC50J2372FS		5905-00-335-7858	C4	66
81349	RNC50J2432FS		5905-00-182-8103	C4	70
81349	RNC50J2492FS		5905-01-067-4888	C4	67
81349	RNC50J2612FS		5905-00-182-8104	C4	64
81349	RNC50J2672FS		5905-01-080-1503	C4	63
81349	RNC50J2742FS		5905-01-023-8084	C4	62
81349	RNC50J2802FS		5905-01-080-1512	C4	61
81349	RNC50J2872FS		5905-01-023-8999	C4	60
81349	RNC50J2942FS		5905-00-182-8105	C4	73
81349	RNC50J3012FS		5905-00-262-5271	C4	65
81349	RNC50J8251FS		5905-00-112-1308	C4	76
81349	RNC55H4531FS		5905-00-468-3020	C4	130
81349	RNC55H4751FS		5905-00-412-4049	C4	128
81349	RNC55J5112BS		5905-00-721-0815	C7	21
01139	RTV3145		5970-01-340-3255	BULK	5
81349	RWR81N56R2FS		5905-01-200-7320	C10	17
81349	RWR81SR100FS		5905-01-169-0036	C4	142
81349	RWR81SR200FR		5905-01-388-8231	C4	123
81349	RWR81SR619FS		5905-01-140-5573	C4	116
81349	RWR81S1001FS		5905-01-082-4272	C4	134
81349	RWR81S8R25FS		5905-01-174-8473	C4	114
81349	SE11C01S			C7	37
81349	SE11XC01S		5940-01-221-6415	C5	35
				C10	20
81348	SN63WRMAP3		3439-01-398-3036	BULK	23
55719	TMP12A		5120-01-367-3497	C11	12
06090	TMS-SCE 1/2-2.09		5970-01-355-5982	C9	8
S7040	TM6706567-0			C5	31
S7040	TM6706568-0			C5	14
S7040	TM6707404-0		5950-01-447-8128	C4	42
S7040	TM6707405-0		5950-01-447-8133	C4	144

## CROSS-REFERENCE INDEXES

CAGEC	PART NUMBER	PART NUMBER INDEX		FIG.	ITEM
			STOCK NUMBER		
S7040	TM6707406-0			C4	145
S7040	TM6707407-0		5950-01-447-8132	C4	146
S7040	TM6707408-0		5950-01-447-8136	C4	147
S7040	TM6707409-0		5950-01-447-8134	C4	148
S7040	TM6707410-0			C4	149
S7040	TM6707411-0			C4	150
96508	TS30			C11	6
06090	TXR40AB90-1406BI		5935-01-474-8331	C10	8
12969	UC1843J/883B		5962-01-289-7408	C4	152
S7040	WA6706563-0			C2	23
S7040	WA6707296-0		6150-01-417-0902	C11	38
S7040	WA6708068-0			C11	30
S7040	WA6708103-0		6145-01-474-8329	C11	22
S7040	WA6708167-0		6145-01-474-8328	C11	31
S7040	WA6708170-0		6145-01-474-8327	C11	29
S7040	WA6708171-0		6145-01-474-8333	C11	19
66579	WS27C256F-55DMB			BULK	11
				BULK	12
				BULK	13
S7040	WT6707886-0		5930-01-444-4571	C7	82
S7804	OWA6707293-0			C11	25
83284	10008		4940-01-278-4142	C11	4
28480	1070B		6625-01-448-4891	C11	17
98571	107022		5940-00-258-2106	C10	21
19200	12922096			C8	4
19200	12922110		5342-00-985-0248	C8	5
19200	13002074		5895-01-417-7101	C1	1
19200	12979003		5340-01-440-5938	C1	3
19200	12979004		6150-01-446-1595	C1	4
19200	12979006		5935-01-435-4414	C1	2
19200	12979007		9905-01-446-1594	C2	5A
19200	12979008		5306-01-446-1596	C8	1
19200	12991852		6150-01-475-4290	C1	5
23338	178			C11	16
06090	201M112-19B		5935-01-223-9820	C9	5
				C10	11
06090	202S142-25S		5975-01-291-6323	C9	3
				C10	9
06090	202S163-25S		5340-01-450-1988	C10	5
06090	209M312-19B			C9	2
06090	209M314-19B			C10	8
06090	209M418-19B		5935-01-459-6068	C10	2
26805	2098-0275-54		5120-01-173-6247	C11	35
06090	222S152-25S		5975-01-385-8686	C10	1
06090	234A011-3		5970-00-908-4200	BULK	8
06090	301A022-3		5970-00-923-7173	C10	6
50893	31335		5120-01-367-7652	C11	21
22915	340475		5962-01-182-0577	C7	53
28480	3478A		6625-01-171-9937	C11	37
9K946	382S023-3S		5970-01-376-5868	C10	10
29685	4M			C11	32



SECTION IV

TM9-1290-365-24&amp;P

## CROSS-REFERENCE INDEXES

CAGEC	PART NUMBER	PART NUMBER INDEX		FIG.	ITEM
			STOCK NUMBER		
28480	5350B		6625-01-267-4887	C11	26
67268	5962-8866203NA		5962-01-406-2375	C7	45
67268	5962-8867004LA		5962-01-372-6876	BULK	14
67268	5962-8956101EA		5962-01-372-3606	C7	58
67268	5962-9071103MEA		5962-01-420-8941	C7	59
18565	60-11-4374-1674		5970-01-223-1416	C4	165
99899	640		5985-00-729-1297	C11	18
05972	747-55		8030-00-082-2508	BULK	19
76381	75 1/2		5970-01-464-0254	C7	75
76381	75 1/4			BULK	25
89536	77-2		6625-01-168-6856	C11	5
05972	83-31		8030-00-081-2330	BULK	20
80249	890664		5950-00-931-4014	C11	34
19200	9255736		5962-01-189-4489	C7	55
49956	952536-3		5962-01-136-4640	C4	154



**APPENDIX D  
OVERHAUL PROCEDURES**

**APPENDIX CONTENTS**

<b>Title</b>	<b>Page</b>
SECTION I. GENERAL.....	D-1
SECTION II. TECHNICAL SUPPORT REQUIREMENTS.....	D-2
SECTION III. PRESHOP ANALYSIS.....	D-3
SECTION IV. TRANSCEIVER ASSEMBLY, PINs AY6707292-3, AY6707292-4 and AY6707292-5.....	D-7
SECTION V. DOPPLER AMPLIFIER CCA, P/N AY6706566-O.....	D-49
SECTION VI. POWER SUPPLY MODULE, P/N AY6707291-O.....	D-63
SECTION VII. MVP CCA, P/N AY6707288-3, AY6707288-4 and AY6701 0314.....	D-81
SECTION VIII. EMI FILTER MODULE, P/N AY6707289-4 and AY6707289-3.....	D-107
SECTION IX. MICROWAVE TEST EQUIPMENT, DESCRIPTION AND CALIBRATION.....	D-113

**SECTION I. GENERAL**

**SECTION CONTENTS**

<b>Subject</b>	<b>Page</b>
Scope.....	D-1
General Information.....	D-1

**D.1 GENERAL.**

**D.1.1 Scope.** This appendix provides instructions for use by depot personnel. They are detailed testing and repair procedures that apply to the M93 Muzzle Velocity System (MVS) transceiver and in case of conflict take precedence over other documents pertinent to the overhaul of the M93 MVS transceiver. The condition of an overhauled M93 MVS transceiver shall be that utility and performance are equal to that of a condition code A, as defined in AR 725-50.

No item shall be repaired/restored if replacement is more cost effective. Unless exempt, the item repair shall not exceed Maintenance Expenditure Limit (MEL) without an approval waiver in accordance with AMC-R 750-51.

**D.1.2 General Information.** This appendix is divided into 9 sections. Sections I and II contain general and technical support information. Section III contains the preshop analysis requirements. Section IV contains depot level procedures for the M93 MVS transceiver. Sections V through VIII contain instructions for subassemblies identified as faulty. Section IX provides the description and calibration requirements for the special microwave test equipment. Sections provide removal, disassembly, cleaning, inspection, troubleshooting, repair, and assembly for each assembly and subassembly.

SECTION II. TECHNICAL SUPPORT REQUIREMENTS

SECTION CONTENTS

Subject	Page
Facilities .....	D-2
Test Equipment and Special Tools .....	D-2
Material Required .....	D-2
Fabricated Tools and Equipment .....	D-2
Mandatory Replacement Parts .....	D-2
Repair Parts .....	D-2
Modifications .....	D-2

---

**D.2 TECHNICAL SUPPORT REQUIREMENTS.**

**D.2.1 Facilities.** There are no special facilities required to perform this procedure.

**D.2.2 Test Equipment and Special Tools.** The test equipment and special tools required for the maintenance of the M93 Muzzle Velocity System (MVS) transceiver are listed in the appropriate sections for each assembly or subassembly.

**D.2.3 Material Required.** The materials and other consumable items required for the general maintenance of the M93 MVS transceiver are listed in the appropriate sections for each assembly or subassembly.

**D.2.4 Fabricated Tools and Equipment.** No fabricated tools or equipment are required to test and maintain the M93 MVS transceiver at depot maintenance.

**D.2.5 Mandatory Replacement Parts.** There are no mandatory replacement parts required during overhaul of the MVS transceiver.

**D.2.6 Repair Parts.** Refer to Appendix C of this manual for the depot level repair parts that may be required during overhaul.

**D.2.7 Modifications.** All current Modification Work Orders (MWOs) not installed must be applied to the M93 MVS transceiver or its repairable subassemblies before returning the item(s) to stock. Refer to DA PAM 25-30 for published MWOs. Engineering Change Proposals (ECPs) specified by the contractor/procurement work directive (PWD) must also be applied during the overhaul of the item(s).

**SECTION III. PRESHOP ANALYSIS**  
**SECTION CONTENTS**

<b>Subject</b>	<b>Page</b>
Scope .....	D-3
Checking Attached Documents.....	D-3
Unpacking and Special Handling .....	D-3
External Inspection.....	D-3
Cleaning and Preservation.....	D-4
Corrosion.....	D-4
Preshop Analysis .....	D-4
Preshop Analysis Checklist.....	D-4

---

**D.3 PRESHOP ANALYSIS.**

**D.3.1 Scope.** The purpose of preshop analysis is to inspect and test the M93 Muzzle Velocity System (MVS) transceiver prior to performing any repair or overhaul procedures at depot. This will minimize unnecessary disassembly or testing procedures and ensure that the M93 MVS transceiver is repaired in the most efficient manner.

**D.3.2 Checking Attached Documents.** Depot maintenance personnel shall carefully check all tags, forms, and documents attached to the MVS transceiver when it is received. These documents will identify the type of operational faults noted in the MVS transceiver and will indicate any troubleshooting and repair procedure performed at a lower level of maintenance. This information will aid the depot maintenance personnel in diagnosing faults in the MVS transceiver.

**D.3.3 Unpacking and Special Handling.**



**CAUTION**

**This equipment contains assemblies subject to damage by electrostatic discharge. Use approved grounding procedures before touching, removing or inserting printed wiring assemblies.**

The MVS transceiver contains circuit card assemblies (CCA's) that are electrostatic discharge (ESD) sensitive. If CCAS are received at the depot, they should be protected by static shielding bags. Maintenance personnel must wear grounded wrist straps when handling ESD sensitive material, and inspect, test, and repair CCAs at approved static workstations using all precautionary handling techniques.

**D.3.4 External Inspection.** Inspect the M93 MVS Transceiver for damaged and missing parts. Record information on preshop analysis checklist. If any discrepancies are discovered, refer to the applicable repair and replacement procedures provided in the appropriate sections of this appendix.

**Chassis and Cover.** Inspect the chassis and the cover for dents, gouges, scratches, or chipped paint  
**Antenna Radome.** Inspect radome for physical damage. No paint is allowed on radome. Clean if necessary.

- a. Chassis and Cover. Inspect the chassis and the cover for dents, gouges, scratches, or chipped paint
- b. Antenna Radome. Inspect radome for physical damage. No paint is allowed on radome. Clean if necessary.

## **ARMY TM 9-1290-365-24&P**

- c. Connector. Inspect the connector for missing protection cap, cap chain, bent or missing pins, broken body, and secure mounting.
- d. Identification Plate. Inspect for missing or damaged identification plate.
- e. Threaded Pails. Inspect all threaded parts for crossed, stripped, or otherwise damaged threads.
- f. Circuit Card Assemblies. Inspect CCA's IAW their respective inspection requirements.

**D.3.5 Cleaning and Preservation.** If necessary, clean and paint the MVS transceiver in accordance with paragraphs 3.1.3 and 3.1.5 of Chapter 3 in this manual.

**D.3.6 Corrosion.** Refer to paragraph 1.6 of Chapter 1 in this manual for actions required if a corrosion problem is identified.

**D.3.7 Preshop Analysis.** Refer to Table D-1 for the preshop analysis checklist. The table lists the inspections/tests that are necessary to evaluate the condition of the MVS Transceiver prior to overhaul and to determine the maintenance tasks required during overhaul. The checklist should be reproduced locally, as required, for recording preshop analysis checks.

**D.3.8 Preshop Analysis Checklist.** The checklist provides the areas to be inspected and is divided into five columns. The assembly and serial numbers must be filled in. The person receiving the item is to review any accompanying tags or forms, check off either or both, if applicable, then sign and date the sheet. The column headings and purposes are:

- a. Column 1: Inspection Point. This column indicates the assembly or item to be inspected or tested.
- b. Column 2: Condition. This column indicates the inspection or test to be performed by maintenance personnel to determine the condition of the assembly or item.
- c. Column 3: Action. This column lists the test or repair action required to correct a faulty condition.
- d. Column 4: Remarks. This column provides space for the maintenance personnel to indicate the results of the inspection, repair or test.
- e. Column 5: Done. This column provides space for maintenance personnel to indicate completion of each preshop analysis check

Table D-1. Preshop Analysis Checklist

Assembly No.: \_\_\_\_\_

Ser. No.: \_\_\_\_\_

Reviewed Tags? \_\_\_\_\_

Reviewed Forms? \_\_\_\_\_

Inspection Point	Condition	Action	Remarks	Done
M93 MVS System	No visual physical damage	Para. D.3.4		
Transceiver Assy	Scratched, gouged, chipped paint	Para. D.4.10		
	Bent, broken, missing connector contacts	Replace EMI filter IAW para's. D.4.6.9 and D.4.11.1		
	Broken connector body	Replace EMI filter IAW para's. D.4.6.9 and D.4.11.1		
	Insecure connector mounting	Para. D.4.11.1		
	Painted antenna radome	Para. D.4.7		
	Scratched antenna radome	Para. D.4.8d.		
	Cut, disturbed, exposed antenna radome	Replace microstrip antenna IAW para's D.4.6 and D.4.11.1		
	Torn, deteriorated, punctured gasket	Para's. D.4.6.4 and D.4.11.5		
	Frayed wires or insulation, burnt or shorting conditions	Replace using standard shop procedures.		
CCAs	Functional fault	Para. D.4.12		
	Cracked bodies, loose terminals, broken leads, cold solder joints, or otherwise damaged or deteriorated parts	Replace using standard shop procedures.		
EMI Filter Module	Functional fault	IAW applicable section for the faulty CCA		
	Bent, broken, missing connector contacts. Broken connector body. Insecure connector mounting.	Para. D.8.8		
	Functional fault	Para. D.8.11		

Additional remarks: \_\_\_\_\_

\_\_\_\_\_

\_\_\_\_\_

\_\_\_\_\_

Inspected by: \_\_\_\_\_

Date: \_\_\_\_\_





**SECTION IV. TRANSCIVER ASSEMBLY, PINs  
AY6707292-3, AY6707292-4 and AY6707292-5**

**SECTION CONTENTS**

<b>Subject</b>	<b>Page</b>
General.....	D-7
Test Equipment and Special Tools Required.....	D-7
Materials Required.....	D-9
General Repair Requirements.....	D-9
Transceiver Assembly Configurations.....	D-10
Transceiver Assembly Disassembly.....	D-11
Cleaning.....	D-24
Visual Inspection.....	D-24
Repair.....	D-24
Painting.....	D-24
Transceiver Assembly Reassembly.....	D-24
Testing.....	D-27
Troubleshooting.....	D-45
Final Testing.....	D-48

**D.4 TRANSCIVER ASSEMBLY P/N'S AY6707292-3, AY6707292-4, AND AY6707292-5.**

**D.4.1 General.** This section provides repair procedures and maintenance information for the M93 Muzzle Velocity System (MVS) transceiver assembly, P/N AY6707292-3, AY6707292-4, and AY6707292-5. Source, maintenance, and recoverability code is PAODD.

**D.4.2 Test Equipment and Special Tools Required.** Test equipment and special tools requirements are listed in Table D-2. Unless otherwise specified, the test equipment and special tools listed below will be used for testing the transceiver assembly. Each commercially available item of test equipment can be replaced by equipment equivalent to that listed. The microwave items of the test equipment are interconnected and calibrated IAW procedures in Section D.9.

**ARMY TM 9-1290-365-24&P**

*Table D-2. Test Equipment and Special Tools Required*

Nomenclature	Part/Spec. No.	Figure
Test Cable, Paladin Transceiver	RSL, P/N WA6708068-0	C-11, 35
Test Set, Transceiver	RSL, P/N AY6708043-0	C-11, 34
Test Doppler Simulator	RSL, P/N AY67081 72-0	C-11, 36
1553 Bus Simulator	RSL, P/N AY6708116-0	C-11, 37
Serial Communication Cable	RSL, P/N WA67081 67-0	C-11, 38
Personal Computer	IBM 486 PC or compatible	C-11, 19
M93 1553 Test Software: SPC1553.EXE	RSL Software Diskette RD67081 81-0	C-11, 20
1553 Bus Simulation Cable	RSL, P/N WA67081 70-0	C-11, 39
Test Cable, Power	RSL, P/N WA67081 71-0	C-11, 40
Test Cable, M93 System	RSL, P/N WA67081 03-0	C-11, 41
Power And Data Cable, M93 MVS, 0.75m	RSL, P/N WA6707293-0	3-1
Power And Data Cable, M93 MVS, 5m	RSL, P/N WA6707296-0	3-4
Torque Wrench, Bin. lbs., 5/16in	M/A COM, 2098—0275-54	C-11, 21,
Microwave Frequency Counter	EIP, Model 535	C-11, 22
Digital Multimeter (2)	Fluke, Model 77—2	C-11, 5
Electronic Equipment Tool Kit	PPL863	C-11, 11
Function Generator	Wavetek, Model 178	C-11, 23
Oscilloscope	Hewlett Packard, Model 1 070B	C-11, 16
Power Supply, DC (0-40V, 5A)	Lambda, LLS-9040	C-11, 24
Power Supply, DC (0—40V, 1 A), 2 each	Lambda, LLS-5040	C-11, 25
Coaxial Cable, BNC, Male-To-Male, 50ohm (3)	Local Manufacture	N/A
Coaxial Cable, SMA, Male-To-Male, 50ohm (3)	Local Manufacture	N/A
Coaxial Cable, SMC, Female/BNC Male, 50ohm	Local Manufacture	N/A
WR90/SMA Female Adapter (5)	Midwest Microwave, 3625	C-11, 42
RMS Voltmeter	Hewlett-Packard, Model 3400A	C-11, 26
Power Meter	Hewlett-Packard, Model 432B	C-11, 27
Thermistor Mount	Hewlett-Packard, Model 8478B	C-11, 28
Standard Gain Horn	Narda, Model 640	C-11, 29
Pin Switch	General Microwave, Model 9114	C-11, 42
Phase Shifter	Midisco, Model MDCiO89-I	C-11, 42
Fixed Coaxial Attenuator, 20dB	Weinschel, Model 4M	C-11, 30
Variable Waveguide Attenuator	Hewlett-Packard, Model X382A	C-11, 42
Waveguide Directional Coupler	Hewlett—Packard, Model X752D	C-11, 42
Termination, 50ohm	Midwest Microwave, 244AM	C-11, 42

**ARMY TM 9-1290-365-24&P**

*Table D-2. Test Equipment and Special Tools Required (Cont)*

<b>Nomenclature</b>	<b>Part/Spec. No.</b>	<b>Figure</b>
SMA Female/SMA Female Adapter	Midwest Microwave, 2595	C-11, 31
N-Type Female/SMA Male Adapter	Midwest Microwave, 2682	C-11, 32
ESD Work Station Kit	M87893-02	C-11, 13

**D.4.3 Materials Required.** Repair materials and other consumable items required are listed in Table

*Table D-3. Materials Required*

<b>Nomenclature</b>	<b>Part/Spec. No.</b>	<b>Appendix F Item No.</b>
Paint	Color No.383 IAW FED-STD-595 CARC	21
Adhesive	MIL-A-46146, Type III	19
Insulation Compound	MIL-I-46058 TYPE 1B31	9
Solder	SN63WRMAP3	23
Lacing Tape	MIL-T-43435-B3/BLK	11
Solder Sleeve	M8351 9/1-2	28
Bus Wire	QQ-W-343/S-22-S1 T	13
Sealing Compound	83-31	16
Primer	747-55	17
Adhesive	S1125	2
Adhesive	RTV732	29
Acetone	0A51	1
Lockwire	M520995-C22	30
Methylethylketone	ASTM-D-740	14
Antistatic Bag	3271576	31

**D.4.4 General Repair Requirements.** The following general requirements apply to repair of the transceiver assembly:

- a. GENERAL. The transceiver does not contain high voltages or hazardous material. The transceiver radiates low-power X-band microwave energy, therefore RE safety precautions should be taken.
- b. RF-SAFETY. The transceiver radiates microwave energy at approximately 1 mW/cm<sup>2</sup> power density at the antenna surface. Maximum safe level is 10 mW/cm<sup>2</sup> IAW safety level of electromagnetic radiation with respect to personnel. The radar output field does not exceed the safety levels required by ANSI C95.1 - 1982, hazard for humans, by electromagnetic fields at normal or malfunction operation conditions. The transceiver output power is less than 220 mW, which is at any time three orders of magnitude below the requirements of MIL-STD-1358B. Although transmitted power density is less than the safety level, comply with the following warning when the transceiver is transmitting:

**WARNING**

Do not point the radiating surface towards any personnel. Do not bring eyes to close contact with the radiating surface. Use absorbing materials in front of the radiating surface whenever possible.



**CAUTION**

This equipment contains assemblies subject to damage by electrostatic discharge. Use approved grounding procedures before touching, removing or inserting printed wiring assemblies.

**CAUTION**

Exercise extra caution while handling the transceiver and its electrical terminal. Use grounding strap on both hands.

- c. Do not assemble transceiver assembly or covers for at least 24 hours after applying RTV adhesive to internal elements or transceiver assembly gasket.
- d. Use torque wrench 2098-0275-54 (mfr M/A COM) when handling the RF cable WA6706563-0 for final tightening. Do not over torque.
- e. Tag and identify wires before disconnecting.
- f. Use only SN63WRMAP3 tin/lead solder.

**CAUTION**

Insulation compound must not be applied to any connector pins. Inadvertent application of compound to connector pins may require replacement of connector.

- g. Apply uniform coating MIL-I-46058 TYPE 1B31 insulation compound after soldering of wires.
- h. Bond boots to D-type connectors and cables using Raychem S1125 adhesive. Apply heat for curing using heat gun.
- i. Apply primer MIL-S-22473 grade T and sealing compound MIL-S-22473 grade CV to threads.
- j. Verify that screws are fully secured with lockwashers before final assembly. Also, verify that the transceiver is clean from any residues of solder or foreign objects.

**D.4.5 Transceiver Assembly Configurations.**

D.4.5.1 CONFIGURATIONS. The M93 transceiver assembly exists in three operational configurations. Table D-4 provides the cross reference to the respective M93 MVS transceiver assembly configurations. *Table D-4. M93 Transceiver Assembly Configurations*

M93 MVS Transceiver Assembly	MVP CCA	EMI Filter Module	Integrated Simulation Assembly	Microstrip Antenna	Antenna Cover
AY6707292-3	AY6707288-3	AY6707289-1	NONE	EA67061 48-0	AM6707834-0
AY6707292-4	AY6707288-4	AY6707289-1	AY6701 0553	EA67061 48-0	AM6707834-0
AY6707292-5	AY67010314	AY6707289-3	AY6701 0553	EA67061 48-1	AM67010650

D.4.5.2 CONFIGURATION DESCRIPTION.

- a. The M93 MVS transceiver assembly has three basic configurations. The transceiver assembly, AY6707292-5, includes an integrated simulation assembly, AY6701 0553, which allows automatic self test of the microwave section. The transceiver assembly, AY6707292-3, does not include the integrated simulation assembly. The transceiver assembly, AY6707292-1 is an intermediate version, which includes the integrated simulation assembly and a modified muzzle velocity processor (MVP) circuit card assembly (CCA) AY6707288-4
- b. Transceiver assembly, AY6707292-5 has a slightly different mechanically structured microstrip antenna, EA6706148-1, than the other two versions. This is reflected in a different installation of the RF cable, WA6706563-0.
- c. Transceiver assembly, AY6707292-5, has a slightly different mechanically structured antenna cover, (AM6701 0650), than the other two versions.
- d. Transceiver assembly, AY6707292-5, contains a different mechanically structured electro — magnetic interference (EMI) filter module, AY6707289-3, than the other two versions.

D.4.5.3 INTERCHANGEABILITY.

- a. MVP CCA AY6707288-3 can be installed into MVS transceiver assembly AY6707292-3 only. The integrated simulation assembly is not present.
- b. MVP CCA's, AY6707288-4 and AY67010314 are interchangeable, and can be installed into any configuration of the MVS transceiver assembly, without affecting fit, form, or function. The MVP CCA automatically detects the existence of the integrated simulation assembly, and operates accordingly.
- c. Microstrip antenna, EA6706148-1, is interchangeable with microstrip antenna EA6706148-0, and can be installed into any configuration of the MVS transceiver assembly, without affecting fit, form, or function.
- d. Antenna cover AM67010650 is interchangeable with antenna cover, AM6707834-0 and can be installed into any configuration of the MVS transceiver assembly, without affecting fit, form, or function.
- e. EMI filter module AY6707289-3 can be installed into antenna cover AM6701 0650 only.
- f. EMI filter module AY6707289-1 can be installed into antenna cover AM6707834-0 only.
- g. EMI filter CCA is interchangeable between the two EMI filter modules.

D.4.6 Transceiver Assembly Disassembly.

**NOTE**

Disassemble transceiver assembly only to the extent necessary to perform the required maintenance task. Refer to Figures D-1, D-2 or D-3 in all disassembly procedures.

D.4.6.1 SEPARATION OF BRACKET. If necessary, separate the bracket assembly from the transceiver assembly in accordance with paragraph 3.5.7 of Chapter 3 in this manual.

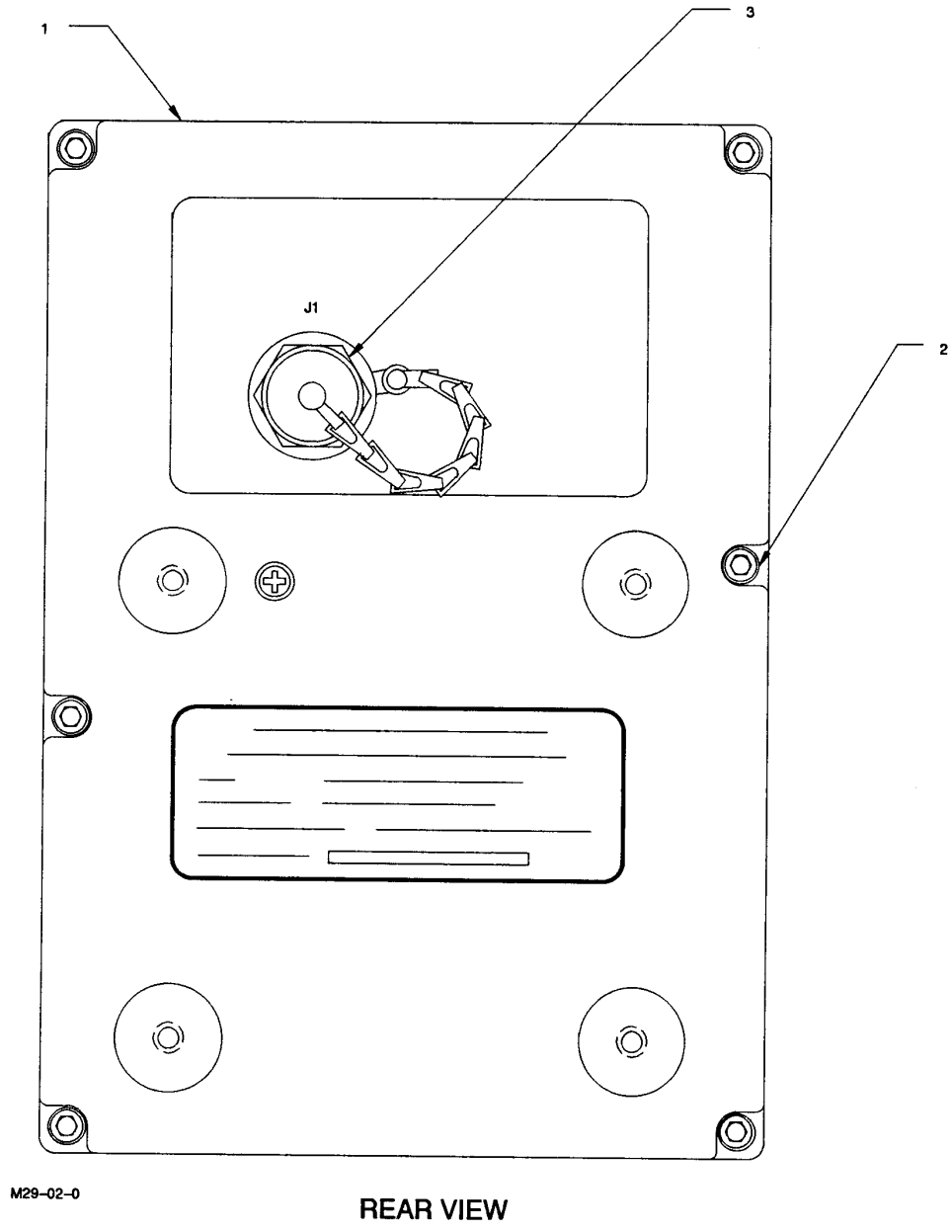
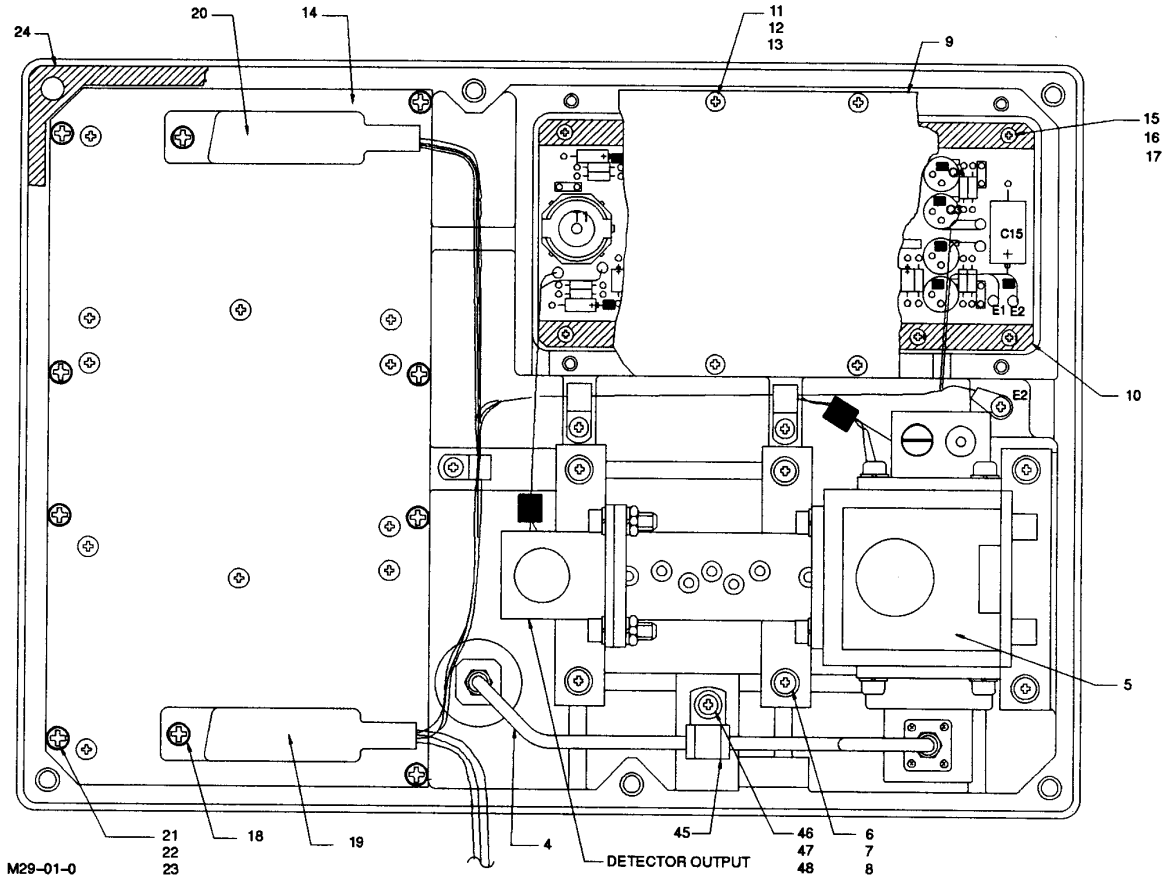
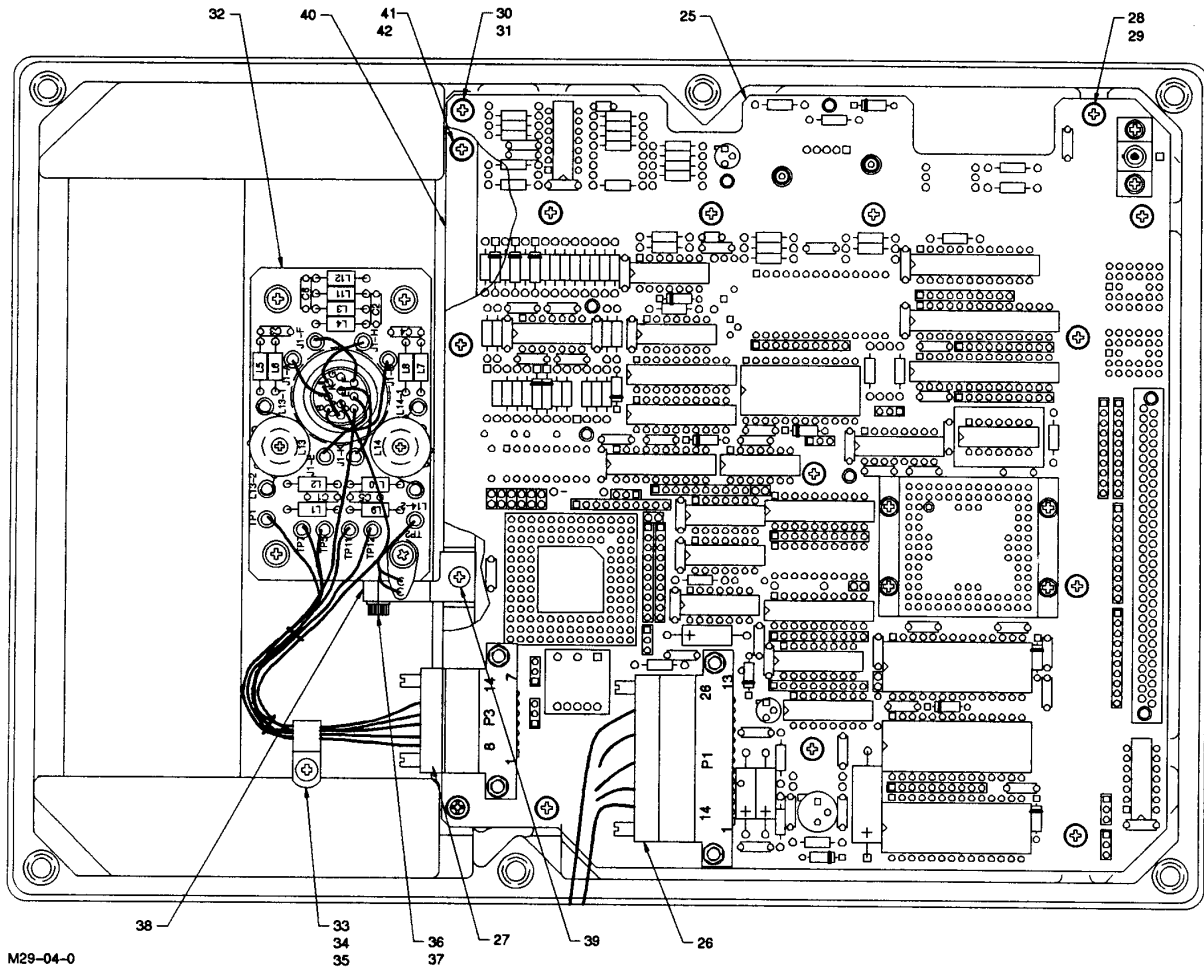

Figure D- 1. Transceiver Assembly AY6707292-3 (Sheet 1 of 3)



**RF SECTION ASSEMBLY**

Figure D-1. Transceiver Assembly AY6707292-3 (Sheet 2 of 3)



**BACK COVER ASSEMBLY**

Figure D-1. Transceiver Assembly AY6707292-3 (Sheet 3 of 3)



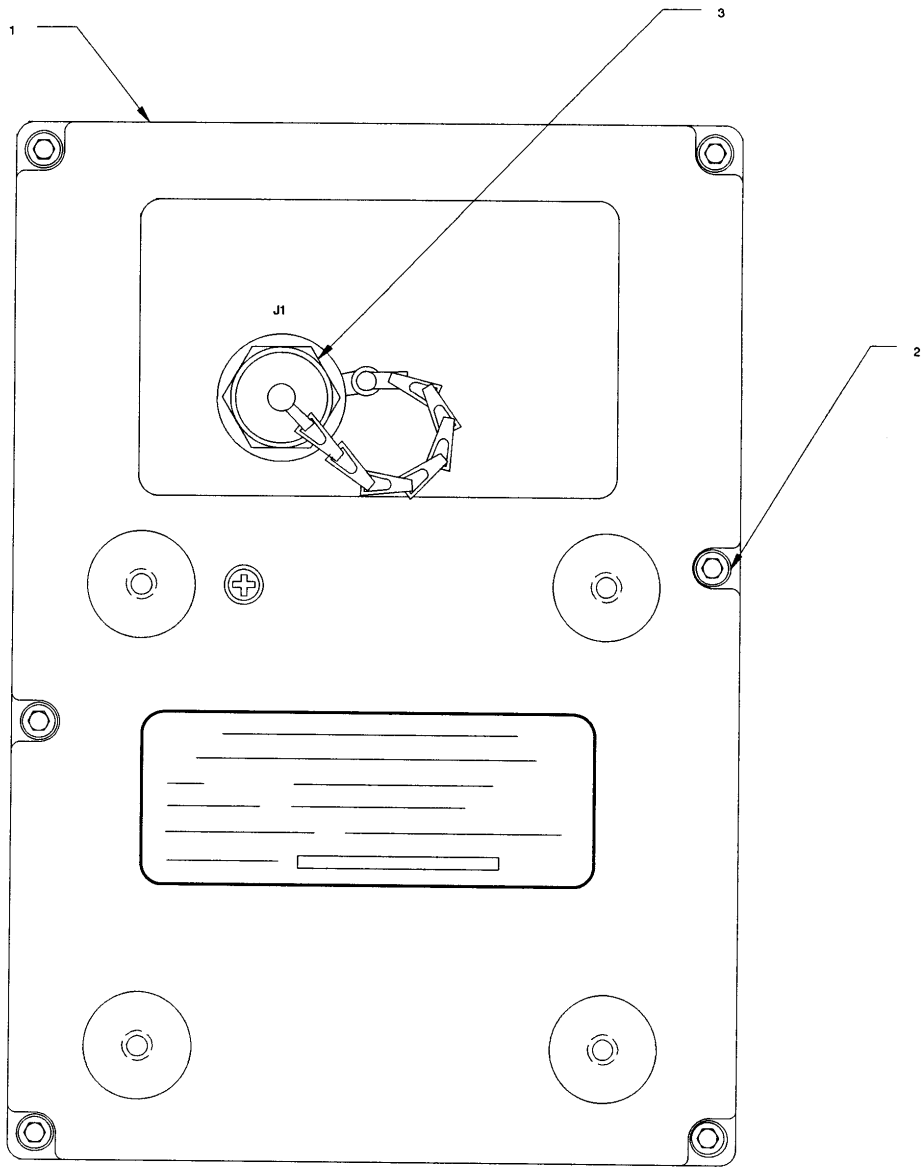

M29-02-1

**REAR VIEW**

Figure D-2. Transceiver Assembly AY6707292-4 (Sheet 1 of 3)

ARMY TM 9-1290-365-24&P

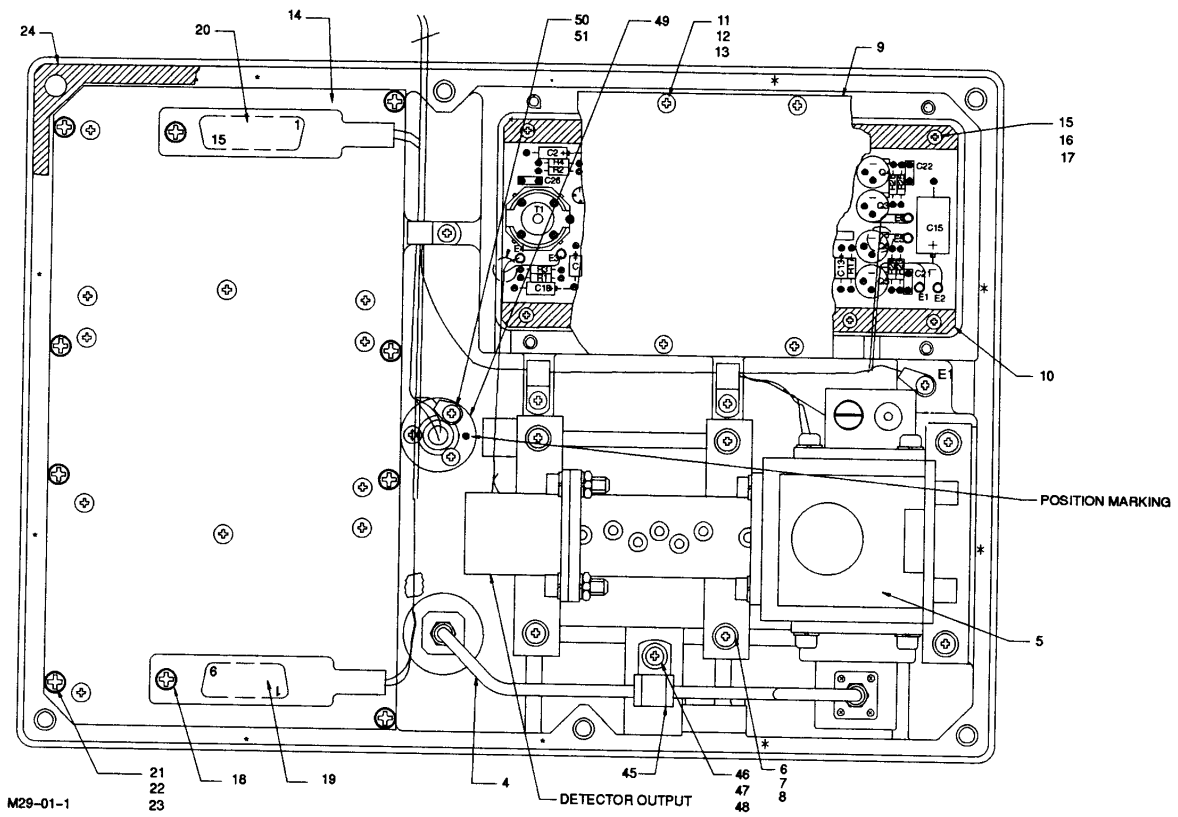

RF SECTION ASSEMBLY

Figure D-2. Transceiver Assembly AY6707292-4 (Sheet 2 of 3)

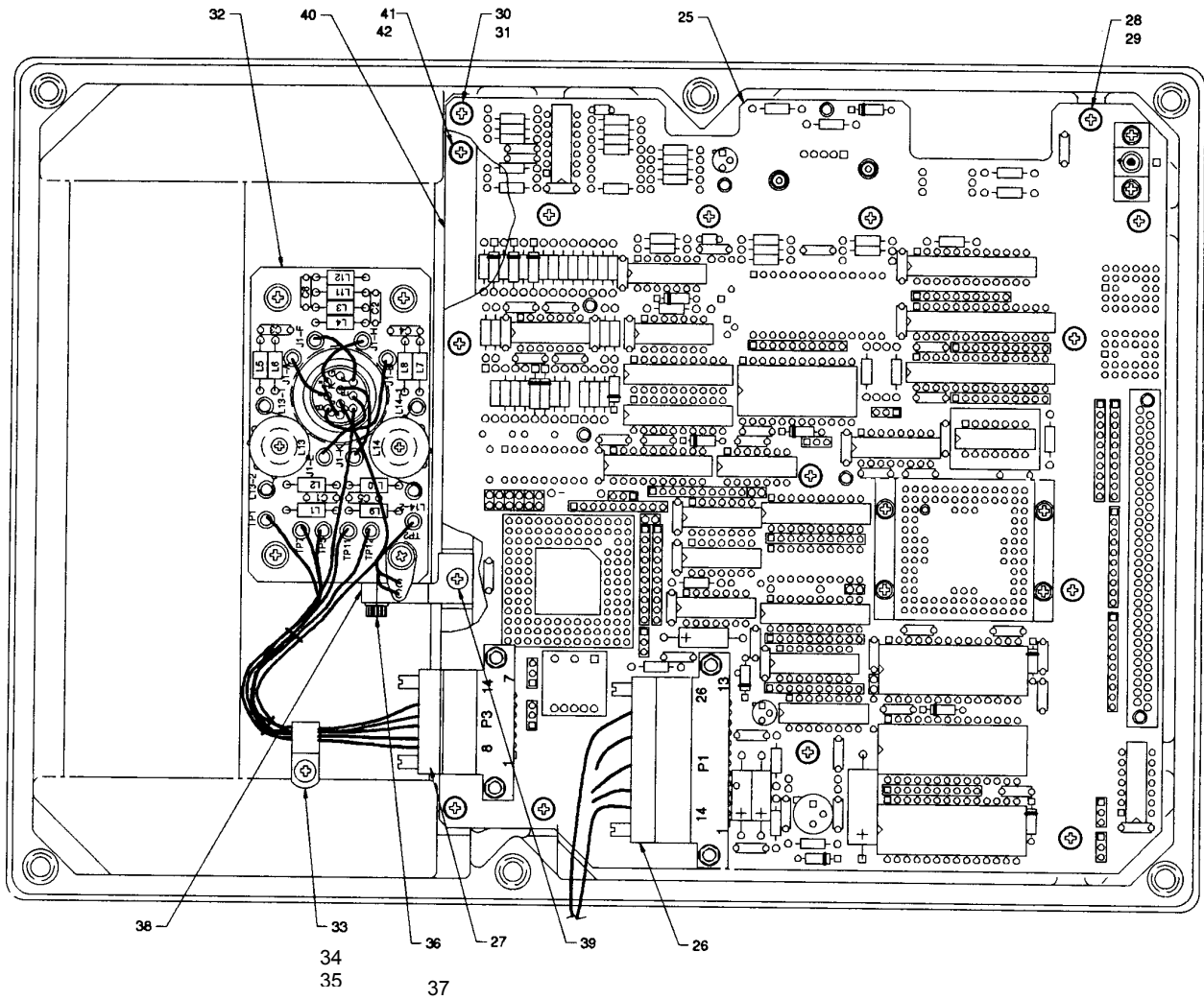

M29-04-1

**BACK COVER ASSEMBLY**

Figure D-2. Transceiver Assembly AY6707292-4 (Sheet 3 of 3)

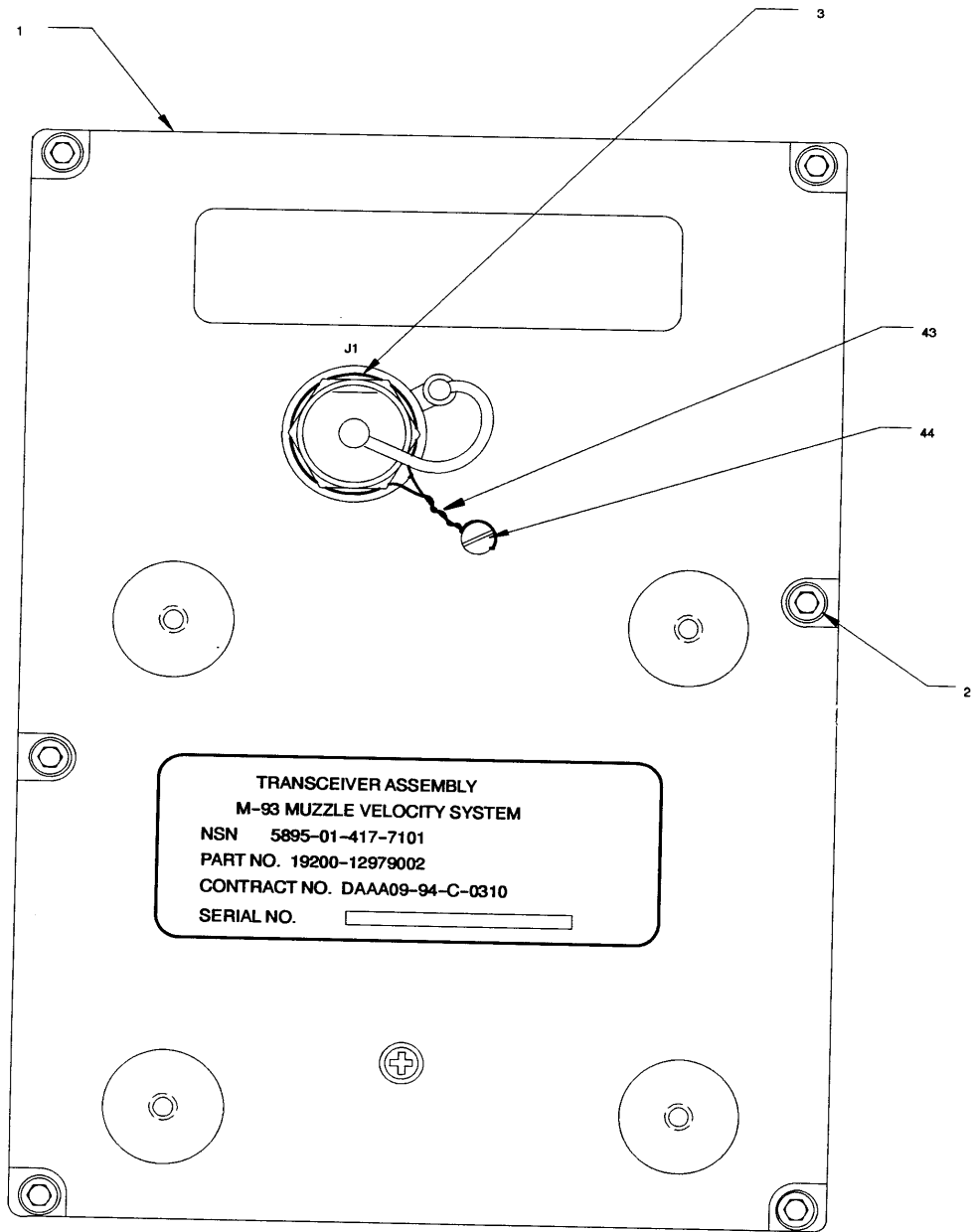

M29-02-2

REAR VIEW

Figure D-3 Transceiver Assembly AY6707292-5 (Sheet 1 of 3)

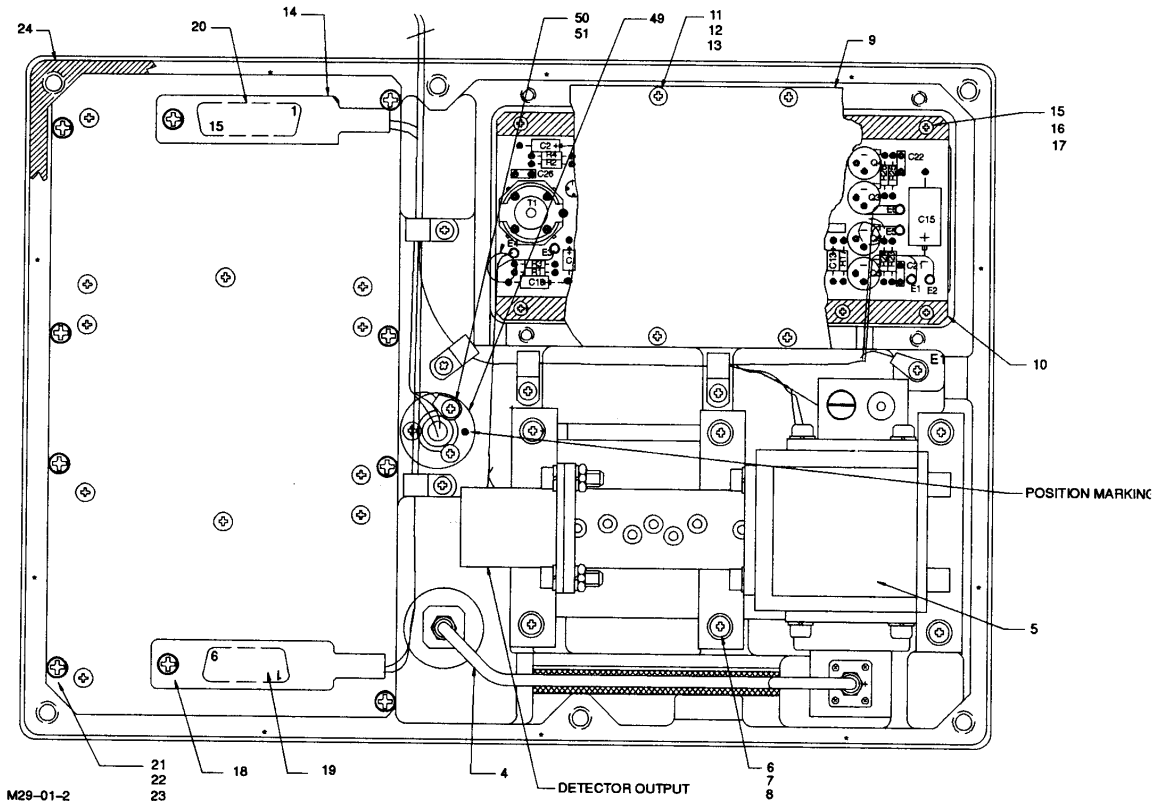

RF SECTION ASSEMBLY

Figure D-3. Transceiver Assembly AY6707292-5 (Sheet 2 of 3)

ARMY TM 9-1290-365-24&P

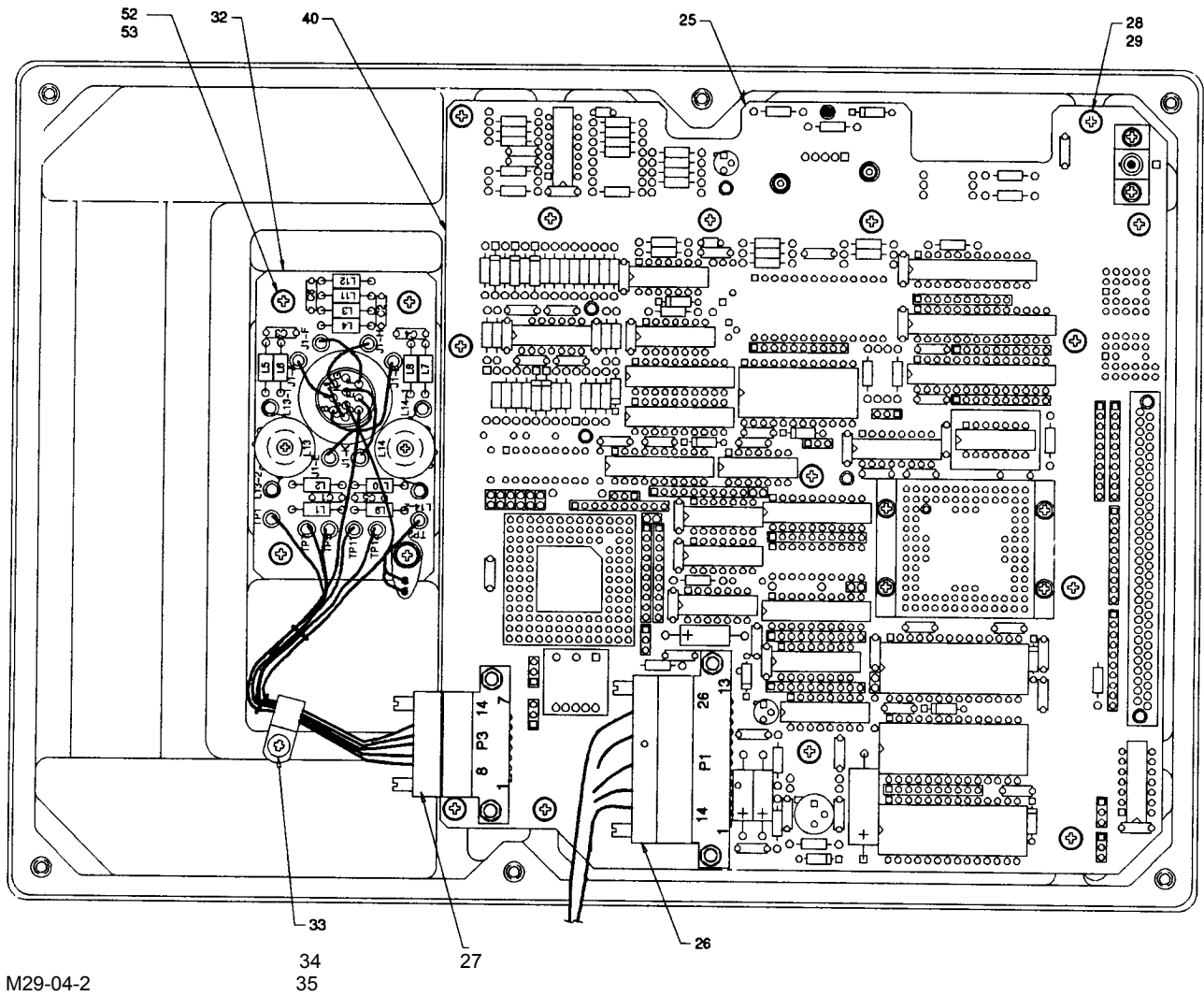

BACK COVER ASSEMBLY

Figure D-3. Transceiver Assembly AY6707292-5 (Sheet 3 of 3)

D.4.6.2 SEPARATION OF TRANSCEIVER ASSEMBLY. Refer to figures D-1., D-2. and D-3.

**CAUTION**

**Separate the two halves of the transceiver assembly carefully to prevent damage to wiring harness attached to both halves.**

- a. Loosen six hex captive screws (2), using a millimeter type hex key.
- b. Carefully separate transceiver assembly (1) into two halves.

D.4.6.3 REMOVAL OF RF CABLE.

D.4.6.3.1 Configuration AY6707292-3 and AY6707292-4 Refer to Figures D-1, D-2., and D-4.

- a. Remove screw (46), lock washer (47) and flat washer (48) which hold clamp (45). Leave clamp on RE cable (4).
- b. Loosen two SMA connectors of the RE cable (4) using a 5/16" hex wrench.
- c. Unscrew two SMA connectors and remove RE cable (4).
- d. Remove clamp (45) from RE cable (if required).

D.4.6.3.2 Configuration AY6707292-5. Refer to Figures D-3. and D-4.

- a. Loosen two SMA connectors of the RE cable (4) using a 5/16" hex wrench.
- b. Unscrew two SMA connectors and remove RE cable (4).

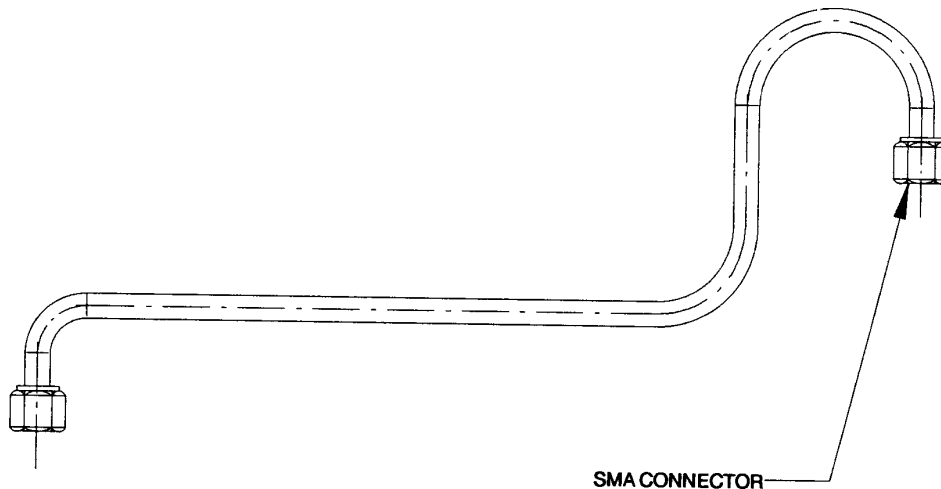

M129-08

Figure D-4. RF Cable, P/N WA6706563

## ARMY TM 9-1290-365-24&P

D.4.6.4 REMOVAL OF TRANSCEIVER. Refer to Figures D-1, D-2, and D-3.



**CAUTION**

**Detector output pin must be grounded at all times.**

- a. Remove RF cable(4) IAW para. D.4.6.3.
- b. Remove six screws (6), six lock washers (7) and six flat washers (8) which attach the transceiver (5) to the antenna base.
- c. Short circuit the transceiver's detector output using bus wire QQ-W-343/S-22S1T by first connecting wire to the ground lug, and then to the detector output pin.
- d. Using soldering iron, disconnect one wire from detector output pin, and two wires from the ground lug.
- e. Using soldering iron, disconnect three wires from the oscillator input pin and ground lug.
- f. Place plastic cap for SMA connector on the transceiver output connector.
- g. Remove transceiver (5) and place it in an antistatic bag. Do not remove shorting bus wire.

D.4.6.5 REMOVAL OF GASKET. Refer to Figures D-1, D-2, and D-3.

- a. Gently peel gasket (24) from the surface of the transceiver assembly (1).
- b. Remove remaining gasket material with a soft hand tool in order not to nick or scratch housing surface.

D.4.6.6 REMOVAL OF DOPPLER AMPLIFIER CCA. Refer to Figures D-1, D-2, and D-3.

- a. Remove eight screws (11), eight lock washers (12) and eight flat washers (13) from CCA cover (9).
- b. Remove Cover (9).
- c. Tag and identify six wires connected to CCA.
- d. Using soldering iron, disconnect six wires.
- e. Remove 12 screws (15), 12 lock washers (16) and 12 flat washers (17) from CCA (10).
- f. Remove CCA (10) from transceiver assembly (1) and place it in antistatic bag.

D.4.6.7 REMOVAL OF POWER SUPPLY MODULE. Refer to Figure D-1, D-2, and D-3.

- a. Loosen four screw locks (18) securing connectors (19,20) to the module (14).
- b. Remove eight screws (21), eight lock washers (22) and eight flat washers (23) from module (14).
- c. Remove module (14) from transceiver assembly (1) and place it in antistatic bag.

D.4.6.8 REMOVAL OF MVP CCA.

D.4.6.8.1 Configuration AY6707292-3 and AY6707292-4 Refer to Figures D-1, and D-2.

- a. Loosen two screws of connector (27).
- b. Loosen two screws of connector (26).
- c. Remove three screws (30) and three flat washers (31) from MVP CCA (25).
- d. Remove ii screws (28) and 11 flat washers (29) from MVP CCA (25).
- e. Remove MVP CCA (25) from transceiver assembly (1) and place it in antistatic bag.



D.4.6.8.2 Configuration AY6707292-5. Refer to Figure D-3.

- a. Loosen two screws of connector (27).
- b. Loosen two screws of connector (26).
- c. Remove 14 screws (28) and 14 flat washers (29) from MVP CCA (25).
- d. Remove MVP CCA (25) from transceiver assembly (1) and place it in antistatic bag.

D.4.6.9 REMOVAL OF EMI FILTER MODULE.

D.4.6.9.1 Configuration AY6707292-3 and AY6707292-4 Refer to Figures D-1. and D-2.

- a. Remove screw (33) and flat washer (34) which attach clamp (35).
- b. Loosen two locks of connector (27).
- c. Remove screw (36) and flat washer (37) which attach the EMI filter module (32) to the transceiver assembly (1).
- d. Unscrew protection cap (3) from the external connector.
- e. Using connector pliers, loosen and then remove the external connector nut.
- f. Remove the protection cap (3).
- g. Remove the EMI filter module (32) from the transceiver assembly (1).
- h. Place the connector nut on the connector, and place the module in antistatic bag.

D.4.6.9.2 Configuration AY6707292-5. Refer to Figure D-3.

- a. Remove secure wire (43).
- b. Unscrew protection cap (3) from the external connector.
- c. Using connector pliers, loosen and then remove the external connector nut.
- d. Remove the protection cap (3).
- e. Remove screw (33) and flat washer (34) which attach clamp (35).
- f. Loosen two locks of connector (27).
- g. Remove four screws (52) and four flat washers (53) which attach the EMI filter module (32) to the transceiver assembly (1).
- h. Remove the EMI filter module (32) from the transceiver assembly (1).
- i. Place the connector nut on the connector, and place the module in antistatic bag.

D.4.6.10 REMOVAL OF INTEGRATED SIMULATION ASSEMBLY. Refer to Figures D-2. and D-3.

**NOTE**

Applies to configurations AY6707292-4 and AY6707292-5 only.

- a. Remove three screws (50) and three flat washers (51).
- b. Tag and identify two wires connected to integrated simulation assembly (49).
- c. Using extraction tool, remove wire from connector P4 (26), pin 16.
- d. Remove solder sleeve that connects wires to connector P4 (26), pin 8.
- e. Remove integrated simulation assembly (49) from transceiver assembly (1) and place it in antistatic bag. Make sure not to damage SMD components.

## **ARMY TM 9-1290-365-24&P**

**D.4.7 Cleaning.** Refer to para. 3.1.3 in Chapter 3 of this manual.

### **D.4.8 Visual Inspection.**

- a. Inspect external connector for damaged pins and foreign matter.
- b. Inspect transceiver assembly for cracks, corrosion and damaged hardware.
- c. Inspect transceiver assembly for damaged circuit cards and damaged or missing components.
- d. Inspect antenna radome for scratches and pits. These conditions shall be acceptable providing the laminated fiber is not cut, disturbed, or exposed.
- e. Inspect gasket for deterioration, punctures, and tears.
- f. Inspect all wiring for bent or broken leads, cracked, frayed, deteriorated, worn, overheated or burnt insulation, and secure attachment. Check lacing for secure attachment.

**D.4.9 Repair.** Repair defective parts that were detected during preshop analysis (para. D.3) and visual inspection (para. D.4.8).

**D.4.10 Painting.** Refer to para. 3.1.5 in Chapter 3 of this manual.

### **D.4.11 Transceiver Assembly Reassembly.**

#### **D.4.11.1 ASSEMBLY OF EMI FILTER MODULE.**

**D.4.11.1.1 Configuration AY6707292-3 and AY6707292-4** Refer to Figures D-1 and D-2.

- a. Insert the EMI filter module (32) into the transceiver assembly (1).
- b. Install the protection cap's (3) chain ring on the external connector.
- c. Using connector pliers, secure the external connector with its nut.
- d. Attach the EMI filter module (32) to the transceiver assembly (1) with screw (36) and flat washer (37).
- e. Plug connector (27) into plug P3 of MVP CCA (25) and secure the connector by fastening the two locks.
- f. Install and fasten clamp (35) with screw (33) and flat washer (34).

**D.4.11.1.2 Configuration AY6707292-5.** Refer to Figure D-3.

- a. Insert the EMI filter module (32) into the transceiver assembly (1).
- b. Install the protection cap's (3) chain ring on the external connector.
- c. Using connector pliers, secure the external connector with its nut.
- d. Attach the EMI filter module (32) to the transceiver assembly (1) with four screws (52) and four flat washers (53).
- e. Plug connector (27) into plug P3 of MVP CCA (25) and secure the connector by fastening the two locks.
- f. Install and fasten clamp (35) with screw (33) and flat washer (34).
- g. Install secure wire (43) using screw (44).

D.4.11.2 INSTALLATION OF MVP CCA.

D.4.11.2.1 Configuration AY6707292-3 and AY6707292-4 Refer to Figures D-1. and D-2.

- a. Place MVP CCA (25) into transceiver assembly (1).
- b. Install and fasten 11 screws (28) and 11 flat washers (29) onto MVP CCA (25).
- c. Install and fasten three screws (30) and three flat washers (31) onto MVP CCA (25).
- d. Plug connector (26) into plug P1 of MVP CCA (25) and secure the connector by fastening the two locks.
- e. Plug connector (27) into plug P3 of MVP CCA (25) and secure the connector by fastening the two locks.

D.4.11.2.2 Configuration AY6707292-5. Refer to Figure D-3.

- a. Place MVP CCA (25) into transceiver assembly (1).
- b. Install and fasten 14 screws (28) and 14 flat washers (29) onto MVP CCA (25).
- c. Plug connector (26) into plug P1 of MVP CCA (25) and secure the connector by fastening the two locks.
- d. Plug connector (27) into plug P3 of MVP CCA (25) and secure the connector by fastening the two locks.

D.4.11.3 INSTALLATION OF POWER SUPPLY MODULE. Refer to Figures D-1, D-2, and D-3.

**CAUTION**

**Make sure to match oscillator operating voltage with power supply module output voltage.**

- a. Place module (14) into transceiver assembly (1).
- b. Install and fasten eight screws (21), eight lock washers (22), and eight flat washers (23) onto module (14).
- c. Plug connectors (19,20) to the module (14), and secure by fastening four screw locks (18).

D.4.11.4 INSTALLATION OF DOPPLER AMPLIFIER CCA. Refer to Figures D-1, D-2. and D-3.

- a. Place CCA (10) into transceiver assembly (1).
- b. Install and fasten 12 screws (15), 12 lock washers (16), and 12 flat washers (17) onto CCA (10).
- c. Using soldering iron, connect six wires to CCA (10).
- d. Remove identification tags from wires.
- e. Attach CCA cover (9) with eight screws (11), eight lock washers (12), and eight flat washers (13).

D.4.11.5 INSTALLATION OF GASKET. Refer to Figures D-1, D-2, and D-3.

**WARNING**

**Use Methylenehtylketone (MEK) in a well ventilated area. Avoid breathing vapors.  
Keep away from flame.**

- a. Clean and remove all residue of RTV from transceiver assembly housing. Use an acid brush moistened in MEK solvent.
- b. Remove the adhesive protection tape from the gasket and place gasket (24) on housing using sufficient pressure.

## ARMY TM 9-1290-365-24&P

D.4.11.6 INSTALLATION OF TRANSCEIVER. Refer to Figures D-1, D-2, and D-3.



**CAUTION**

**Detector output pin must be grounded at all times.**

- a. Using soldering iron, connect three wires to the oscillator input pin and ground lug.
- b. Using soldering iron, connect one wire to detector output pin, and two wires to the ground lug. Do not remove shorting wire during soldering.
- c. Disconnect the shorting wire from detector output pin. First disconnect from the pin, and then from ground lug.
- d. Place transceiver (5) into transceiver assembly (1).
- e. Install and fasten six screws (6), six lock washers (7), and six flat washers (8) which attach the transceiver (5) to the antenna base.
- f. Install RF cable (4) IAW para. D.4.11.7.

D.4.11.7 INSTALLATION OF RF CABLE.

D.4.11.7.1 Configuration AY6707292-3 and AY6707292-4 Refer to Figures D-1, D-2, and D-4.

- a. Place clamp (45) on RF cable (4).
- b. Install RF cable (4) to its position on the transceiver assembly (1).
- c. Hand tighten two SMA connectors of RF cable (4) to transceiver (5) and antenna connector.
- d. Fasten two SMA connectors of the RF cable (4) using a 5/16" hex wrench.
- e. Install and fasten screw (46), lock washer (47), and flat washer (48) which hold clamp (45)

D.4.11.7.2 Configuration AY6707292-5. Refer to Figures D-3 and D-4.

- a. Install RF cable (4) into its groove on the transceiver assembly (1).
- b. Hand tighten two SMA connectors of RF cable (4) to transceiver (5) and antenna connector, while pressing the RF cable into its groove.
- c. Fasten two SMA connectors of the RF cable (4) using a 5/16" hex wrench.

D.4.11.8 INSTALLATION OF INTEGRATED SIMULATION ASSEMBLY. Refer to Figures D-2. and D-3.

**NOTE**

Applies to configurations AY6707292-4 and AY6707292-5 only.

- a. Using crimping tool, crimp socket pin to wire B of integrated simulation assembly (49).
- b. Using insertion tool, insert wire B into connector P4 (26), pin 16.
- c. Place new solder sleeve on wires that connected to connector P4 (26), pin 8. Refer to Figure FO-21. Shrink solder sleeve using heat gun.
- d. Install integrated simulator assembly (49) into transceiver assembly (1). Note the position marking on the integrated simulation assembly body.
- e. Install and fasten three screws (50) and three flat washers (51).

D.4.11.9 REASSEMBLY OF TRANSCEIVER ASSEMBLY. Refer to Figures D-1, D-2. and D-3.

- a. Attach the two halves of the transceiver assembly (1) to each other.
- b. Fasten six hex captive screws (2).

## D.4.12 Testing.

**WARNING**

**Do not point the radiating surface towards any personnel. Do not bring eyes to close contact with the radiating surface. Use absorbing materials in front of the radiating surface whenever possible.**

**NOTE**

Hereafter, the transceiver assembly will be referred to as the unit under test (UUT).

D.4.12.1 PREPARATION FOR TEST. The test is conducted on a disassembled UUT, in two major steps, RF section test (D.4.12.2) and functional test (D.4.12.3)

The test setups are as shown in Figures D-5., D-6, D-7. and D-11 Figures D-8., D-9., D-10, and D-12 through D-19 are detailed illustrations of the special testers.

- a. Disassemble the UUT IAW para. D.4.6.2.
- b. Disconnect connector P4 (26 on Figures D-1., D-2. and D-3.) from the MVP CCA (25 on Figures D-1., D-2. and D-3.).
- c. Remove the RF cable IAW para. D.4.6.3.
- d. Install the RF cable on the transceiver in such a way that its outer edge points out of the transceiver base.
- e. Energize power supply (PS1) and adjust for +28 0.5 Vdc. Deenergize power supply.
- f. Energize power supply (PS2) and adjust both outputs for  $12 \pm 0.1$  Vdc. Deenergize power supply.
- g. Energize and adjust digital multimeter (DMM)-1 to measure DC volts.
- h. Energize and adjust DMM2 to measure high DC current (10 Amp).
- i. Before connecting the UUT to the test setup, verify that both power supplies are deenergized.

D.4.12.2 RF SECTION TEST.

D.4.1 2.2.1 RF Section Test Procedures. The test setup provided in Figure D-5, shows the equipment used and cable hookup for the first procedural step. Refer to Figure D-9. for schematic of the special test equipment.

D.4.12.2.2 Test Data Sheets. The test data sheets in Table D-5, are to be reproduced locally, as required, for recording the test results. The test data sheets must be completed each time a test section is performed. The completed test data sheets shall be retained and used as a troubleshooting aid.

ARMY TM 9-1290-365-24&P

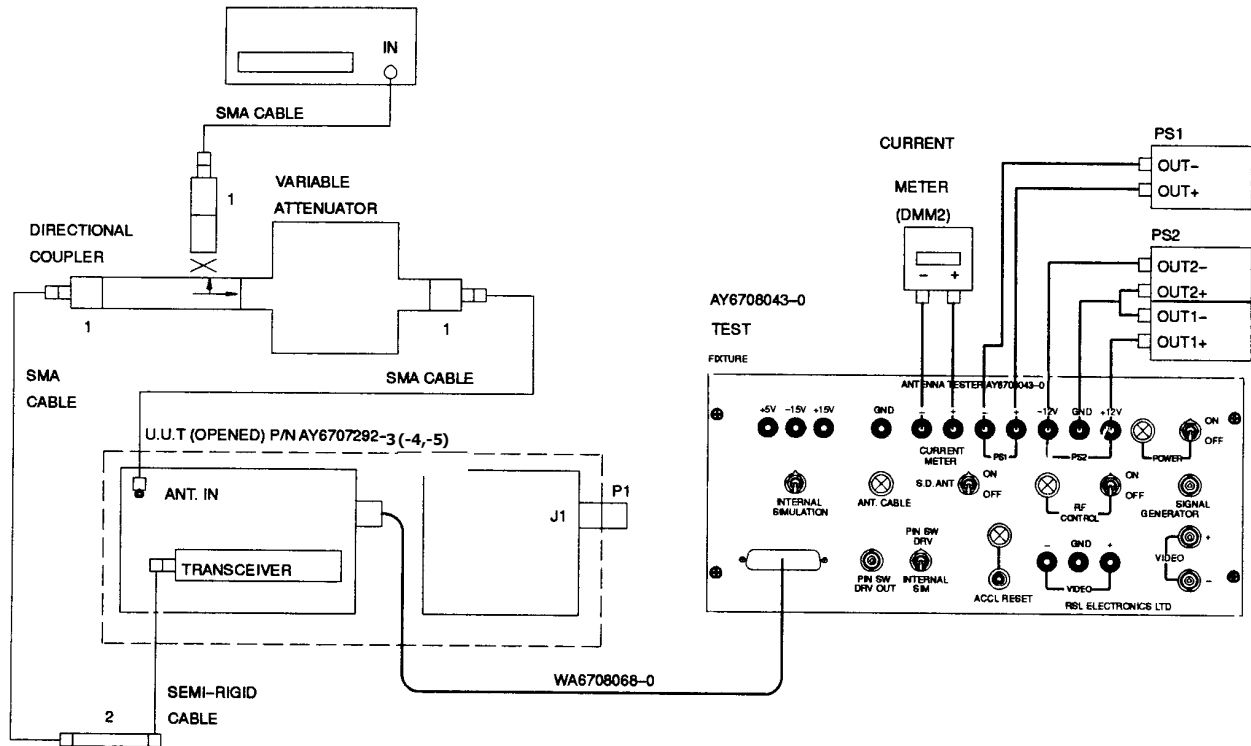

129-60

Figure D-5. Transceiver Assembly Power Supply and Transmitted Frequency Test Setup

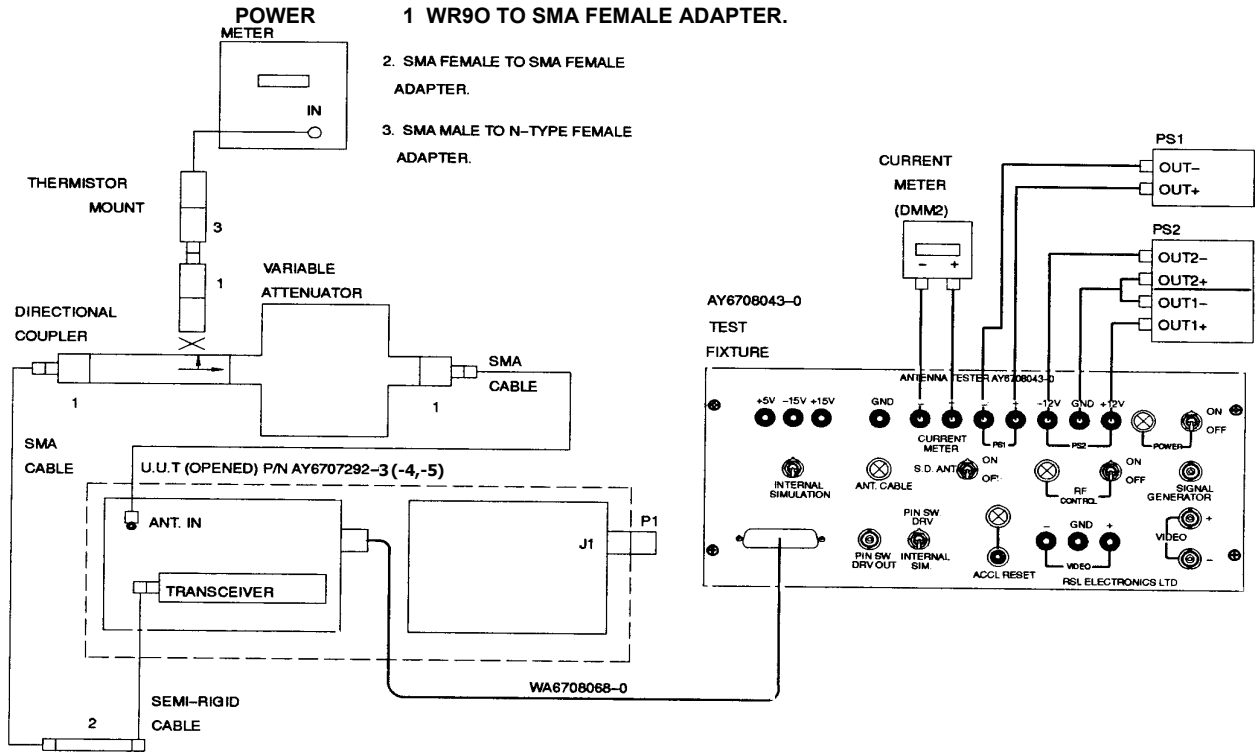

129-61

Figure D-6. Transceiver Assembly Transmitted Power Test Setup

ARMY TM 9-1290-365-24&P

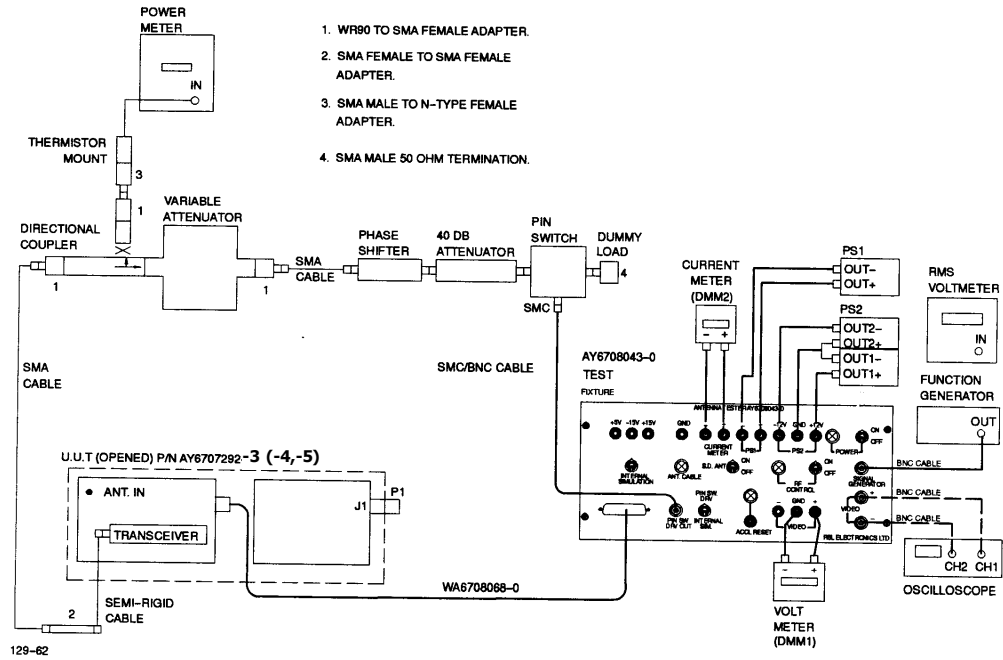

129-62

Figure D-7. Transceiver Assembly Sensitivity Test Setup



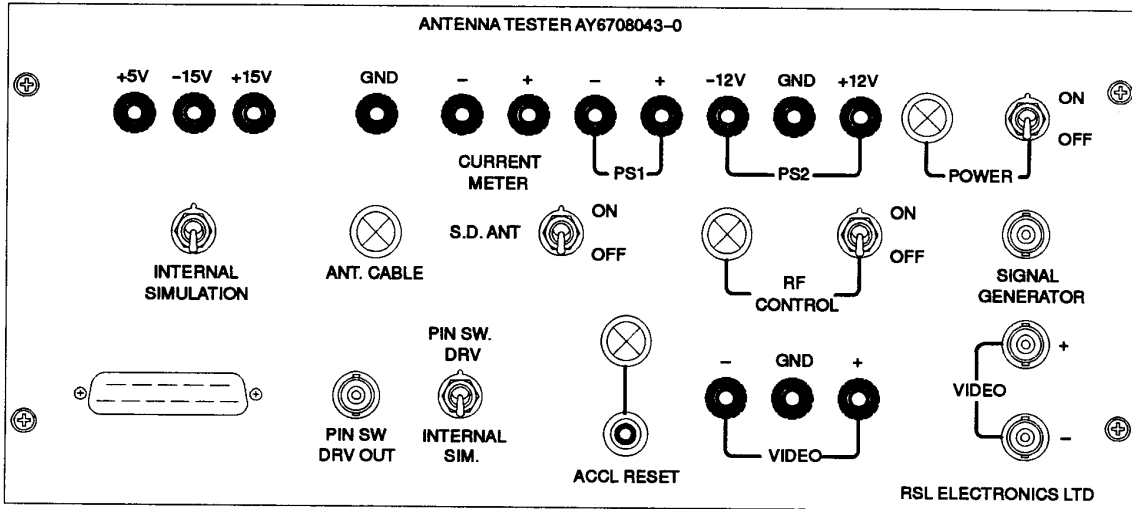

P8044

Figure D-8. Transceiver Assembly RF Section Test Fixture

ARMY TM 9-1290-365-24&P

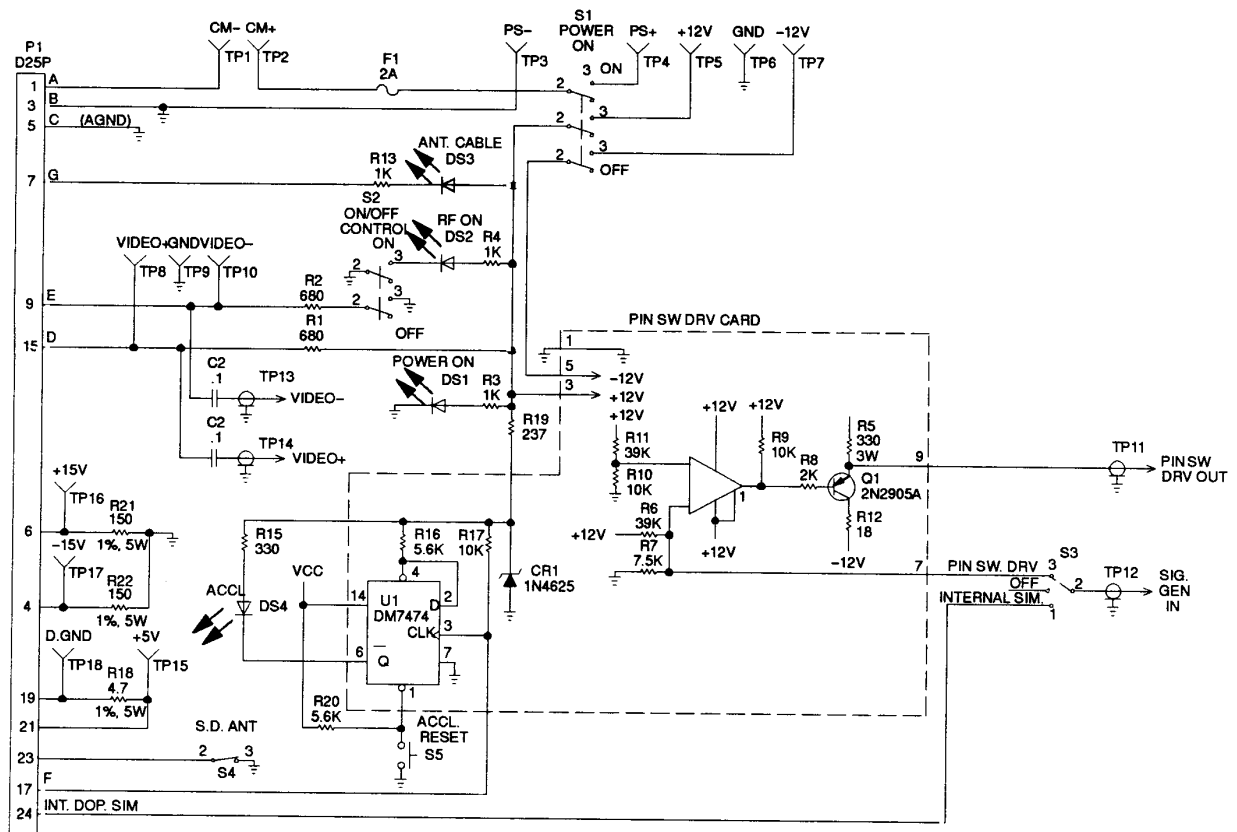

LD670-1 2

Figure D-9. Transceiver Assembly RF Section Test Fixture Schematic

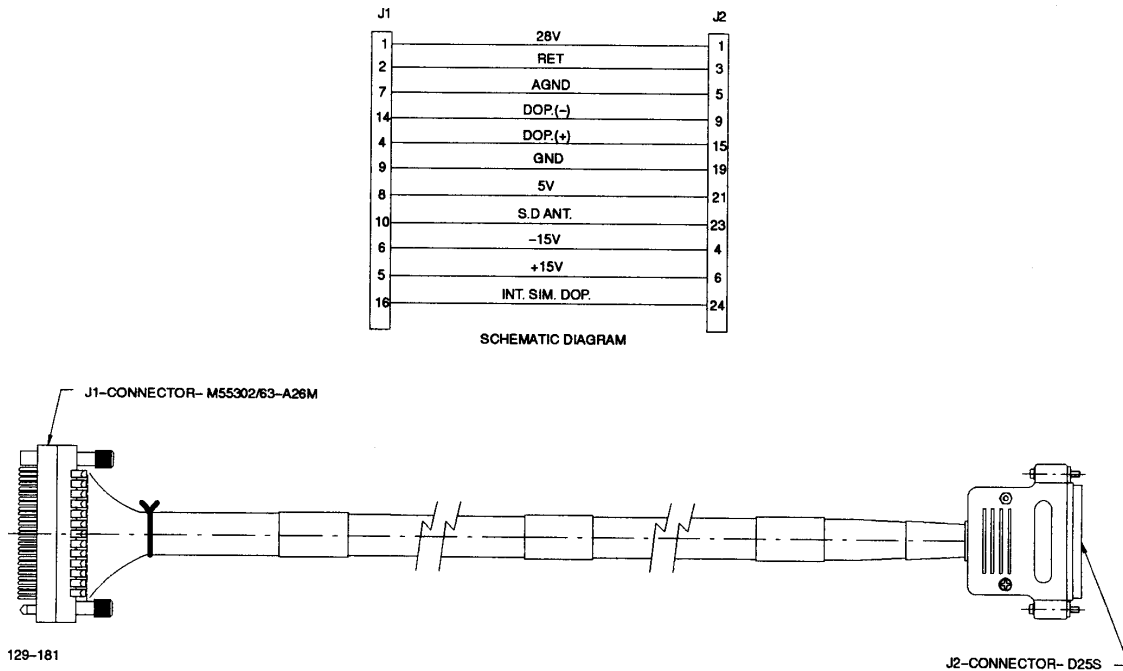

Figure D-10. Transceiver Assembly RF Section Test Cable

D.4.12.2.3 Transceiver Power Supply Tests.

**NOTE**

Power is supplied to the transceiver assembly through the test fixture.

The purpose of this test is to ensure the proper operation of the transceiver assembly for power consumption and on/off control. Refer to para. D.4.13.1 for troubleshooting procedures.

- a. Set POWER and RF CONTROL switches on the test fixture to OFF.
- b. Connect the transceiver to the test fixture as described in Figure D-5.
- c. Energize both power supplies (PS1, PS2). Turn on the POWER switch on the test fixture.
- d. Verify stand by current consumption on current meter DMM2 is  $400 \pm 200\text{mA}$ .
- e. Connect DMM1 to +5V and GND test points on the test fixture. Verify voltage on DMM1 is  $+5 \pm 0.1\text{Vdc}$ .
- f. Connect DMM1 to +15V and GND test points on the test fixture. Verify voltage on DMM1 is  $+15 \pm 0.2\text{Vdc}$ .
- g. Connect DMM1 to -15V and GND test points on the test fixture. Verify voltage on DMM1 is  $-1 \pm 0.2\text{Vdc}$ .
- h. Turn on the S.D ANT switch on the test fixture.
- i. Verify operating current consumption on current meter DMM2 is  $700 \pm 200\text{mA}$ .
- j. Adjust PS1 output voltage to  $22\text{Vdc} \pm 0.5\text{V}$ .
- k. Verify operating current consumption on current meter DMM2 is  $900 \pm 200\text{mA}$ .
- l. Adjust PS1 output voltage to  $32\text{Vdc} \pm 0.5\text{V}$ .

## ARMY TM 9-1290-365-24&P

- m. Verify operating current consumption on current meter DMM2 is  $500 \pm 200\text{mA}$ .
- n. Adjust PS1 output voltage to  $28\text{Vdc} \pm 0.5\text{V}$ .
- o. Turn off the POWER switch in the test fixture.

D.4.1 2.2.4 Transmitted Frequency Test. The purpose of this test is to ensure the proper accuracy of the transmitted frequency. Refer to para. D.4.13.2 for troubleshooting procedures.

- a. Verify that the frequency counter is properly connected to the directional coupler. Set the frequency counter to 10GHz measuring range.
- b. Set the variable attenuator to 0dB.
- c. Turn on the POWER switch of the test fixture.
- d. Turn on SD.ANT switch on the test fixture.
- e. Wait at least two minutes before performing the frequency measuring.
- f. Verify the transmitted frequency on the frequency counter is  $10525 \pm 6\text{MHz}$ . After measuring, adjust the frequency to  $10525 \pm 1\text{MHz}$ .
- g. Set S.D. ANT and POWER switches on the test fixture to OFF.

D.4.12.2.5 Transmitted Power Test. The purpose of this test is to ensure the proper transmitted power. Refer to para. D.4.13.3 for troubleshooting procedures.

- a. Disconnect the frequency counter from the directional coupler. Connect the power meter as described in Figure D-6. The variable attenuator shall be set to 0dB attenuation.
- b. Set POWER and SD.ANT. switches on the test fixture to ON.
- c. Measure the transmitted power on the power meter and record the results in mW. Expected power at the directional coupler port is 1mW to 3mW(OdBm to 5dBm). Set the power meter to the proper range.
- d. Verify the calculated transmitted power in dBm is  $22.3 \pm 1.5\text{dBm}$ .

$$PT(\text{dBm}) = Pt(\text{dBm}) + KP$$

where:

PT(dBm)= Transmitted power in dBm

Pt(dBm) =  $10 \times \log [Pt(\text{mW})/i \text{mW}]$

Pt(mW) is the power measured in step c. above.

KP = Power calibration factor as indicated on the directional coupler.

- e. Set SD.ANT. and POWER switches on the test fixture to OFF.

D.4.12.2.6 Receiver Sensitivity Test. The purpose of this test is to ensure the proper receiving sensitivity of the transceiver unit. Refer to para. D.4.13.4 for troubleshooting procedures.

- a. Test Setup
  - (1) Connect the test equipment as described in Figure D-7.
  - (2) Set function generator output function to square wave  $50 \pm 1\text{KHz}$ ,  $8 \pm 0.1\text{Vp-p}$  on output.
  - (3) Connect oscilloscope CH1 to VIDEO(+) and CH2 to VIDEO(-) outputs on the test fixture.
- b. Noise Level Test
  - (1) Set the variable attenuator to  $30 \pm 0.5\text{dB}$  attenuation. Set S.D and ANT. POWER switches on the test fixture to ON. Set PIN SW DRV/INTERNAL SIM switch to PIN SW DRV position.
  - (2) Observe the noise level of the video amplifier outputs on both channels of the oscilloscope. Verify that the signal is broad band noise and there are no oscillations.
  - (3) Disconnect both channels of the oscilloscope from the test fixture.
  - (4) Connect the RMS voltmeter input to the VIDEO[+] output on the test fixture.
  - (5) Verify the noise level in mV:  $100\text{mVrms}$  to  $300\text{mVrms}$ .

- (6) Connect the RMS voltmeter input to the VIDEO[-] output on the test fixture.
- (7) Verify the noise level in mV: 100mVrms to 300mVrms.
- c. 50KHz Sensitivity Test. Record the test results on the test data sheet (Table D-5) under the 50KHz section of the sensitivity test.
  - (1) Disconnect the RMS voltmeter from the test fixture. Connect both channels of the oscilloscope to the VIDEO[+] and VIDEO[-] output on the test fixture.
  - (2) Decrease the attenuation of the variable attenuator until the signal on both channels is saturated. Verify the signal voltage level on CH1: VSAT[+] = 13Vp-p minimum.
  - (3) Verify the signal voltage level on CH2: VSAT[-] = 13Vp-p minimum and is reverse polarity to CH1 on the oscilloscope.
  - (4) Set the variable attenuator to 30dBm.
  - (5) Disconnect both channels of the oscilloscope from the test fixture.
  - (6) Connect the RMS voltmeter input to the VIDEO[+] output on the test fixture.
  - (7) Record the noise level in dBm.
  - (8) Decrease the attenuation until the voltage level that is measured on the VIDEO[+] output is  $3 \pm 0.3$ dB above the noise level measured in step (7). Record the RMS signal level in dBm.

**NOTE**

Adjust the phase shifter on the microwave test fixture to get the maximum signal on the RMS voltmeter.

- (9) Record the attenuation of the variable attenuator. Set the variable attenuator to 30dB.
- (10) Disconnect the RMS voltmeter from the VIDEO[+] output and connect it to VIDEO[-] output on the test fixture. Record the noise level in dBm.
- (11) Decrease the attenuation until the Voltage level that is measured on the VIDEO[-] output is  $3 \pm 0.3$ dB above the noise level measured in step (10). Record the RMS signal level in dBm.
- (12) Record the attenuation of the variable attenuator.
- (13) Calculate the receiver sensitivity of VIDEO[+] output (see note):  
S[+] = -106dBm maximum.
- (14) Calculate the receiver sensitivity of VIDEO[-] output (see note):  
S[-] = -106dBm maximum

**NOTE:** Sensitivity calculation

$$S = PT(\text{dBm}) - KS - 2A$$

where:

S - Receiver Sensitivity in dBm

PT(dBm) - Transmitted Power in dBm as was calculated in para.

KS - Sensitivity calibration factor as indicated on the directional coupler.

A - Attenuation of the variable attenuator as measured in step (9) (VIDEO[+]) and step (12) (VIDEO[-]).

- d. 10KHZ Sensitivity Test. Record test results on the test data sheet (Table D-5) under the 10KHz section of the sensitivity test.
  - (1) Set the function generator to 10KHz  $\pm 100$ Hz.
  - (2) Repeat steps D.4.12.2.6c.(1) to d.(14).

**ARMY TM 9-1290-365-24&P**

D.4.1 2.2.7 Integrated Simulator Test (versions AY6707292-4 and AY6707292-5 only). Refer to para. D.4.13.5 for troubleshooting procedures.

- a. Turn POWER, RF CONTROL, SD. ANT switches on the test fixture to OFF. Deenergize power supplies PS1, PS2.
- b. Reinstall the RF cable IAW para. D.4.11.7.
- c. Set function generator output function to square wave  $50 \pm 1$  KHz,  $5 \pm 0.1$  Vp-p at the function generator output.
- d. Connect function generator to INT.SIM input on test fixture.
- e. Energize power supplies PS1, PS2.

Disconnect the RMS voltmeter from the test fixture. Connect both channels of the oscilloscope to the VIDEO[+] and VIDEO[-] output on the test fixture.

- g. Point the antenna radiating surface towards free space. Set S.D. ANT. and POWER switches on the test fixture to ON. Set PIN SW DR V/INTERNAL SIM switch to INTERNAL SIM position.
- h. Verify the signal voltage level on CH1: VSAT[-] = 8Vp-p minimum.
- i. Verify the signal voltage level on CH2: VSAT[-] = 8Vp-p minimum.

D.4.1 2.2.8 Set S. D.ANT and POWER switches to OFF. Deenergize power supplies PS1, PS2. Disconnect the transceiver from the test fixture.

END OF RF SECTION TEST.

*Table D-5. Transceiver Assembly RF Section Test Data Sheet*

TRANSCIVER ASSEMBLY SER NO. \_\_\_\_\_

Para.	Minimum Results	Actual Results	Maximum Results	Pass/Fail	Remarks
D.4.12.2.3d.	200mA		600mA		
D.4.12.2.3e.	+4.9Vdc		+5.1Vdc		
D.4.12.2.3f.	+14.8Vdc		+i5.2Vdc		
D.4.12.2.3g.	-15.2Vdc		-14.8Vdc		
D.4.12.2.3i.	500mA		900mA		
D.4.12.2.3k	700mA		1100mA		
D.4.12.2.3m.	300mA		700mA		
D.4.12.2.4.f.	10524MHz		1052GM Hz		
D.4.12.2.5c.	1.0mW		3.0 mW		
D.4.12.2.5d.	20.8dBm		23.8dBm		
D.4.12.2.6.d.	Broad band noise, no oscillation				
D.4.12.2.6b.(5)	1 00mV		300mv		
D.4.12.2.6b.(7)	100mV		300mv		
D.4.12.2.6.c.	50KHz sensitivity test				
D.4.12,2,6.c(2)	13Vp-p				
2.2.6c. (2)					
D.4.12.6.C.(3)	13Vp-p				
D.4.12.2.6c.(7)	RMS noise level (dBm) =				
D.4.12.2.6c.(8)	RMS signal (dBm) =				

Table D-5. Transceiver Assembly RF Section Test Data Sheet (Cont)

Para.	Minimum Results	Actual Results	Maximum Results	Pass/Fail	Remarks
D.4.12.2.6c.(9)	Variable attenuator attenuation =				
D.4.12.2.6c.(10)	RMS noise level (dBm) =				
D.4.12.2.6c.(11)	RMS signal (dBm) =				
D.4.12.2.6c.(12)	Variable attenuator attenuation =				
D.4.12.2.6c.(13)			-106dBm		
D.4.12.2.6c.(14)			-106dBm		
D.4.12.2.6d.	10KHz sensitivity test				
D.4.12.2.6d.(2)	13Vp-p				
D.4.12.2.6d.(3)	13Vp-p				
D.4.12.2.6d.(7)	RMS noise level (dBm) =				
D.4.12.2.6d.(8)	RMS signal (dBm) =				
D.4.12.2.6d.(9)	Variable attenuator attenuation =				
D.4.12.2.6d.(10)	RMS noise level (dBm) =				
D.4.12.2.6d.(11)	RMS signal (dBm) =				
D.4.12.2.6d.(12)	Variable attenuator attenuation =				
D.4.12.2.6d.(13)			-106dBm		
D.4.12.2.6d.(14)			-106dBm		
D.4.12.2.7h.	8Vp-p				
D.4.12.2.7i.	8Vp-p				

Date: \_\_\_\_\_  
 Tested by: \_\_\_\_\_  
 Inspected by: \_\_\_\_\_

D.4.12.3 2.3 FUNCTIONAL TEST.

D.4.12.3.1 2.3.1 Functional Test Procedures. The test setup provided in Figure D-11. shows the equipment used and cable hookup for the first procedural step.

D.4.12.3.2 Test Data Sheet. The test data sheets in Table D-6., are to be reproduced locally, as required, for recording the test results. The test data sheets must be completed each time a test section is performed. The completed test data sheets shall be retained and used as a troubleshooting aid.

D.4.12.3 2.3.3 Preparation for Test.

- a. Reinstall the RF cable IAW para. D.4.11.7 .7.
- b. Reconnect connector P4 (26 on Figures D-1, D-2. and D-3.) to the MVP CCA (25 on Figures D-1, D-2. and D-3.).
- c. Energize power supply and adjust for +28 ± 0.5Vdc. Deenergize power supply.
- d. Energize and adjust DMM to measure high DC current (10A range).
- e. Place the test Doppler simulator on the transceiver antenna radome using the handle.

**ARMY TM 9-1290-365-24&P**

- f. Set test Doppler simulator switch PS/BAT to PS position.
- g. Set test Doppler simulator switch EXTERNAL/INTERNAL to INTERNAL position.
- h. Before connecting the UUT to the test setup, verify that both power supplies are deenergized.
- i. Connect the UUT to the test setup IAW Figure D-11.

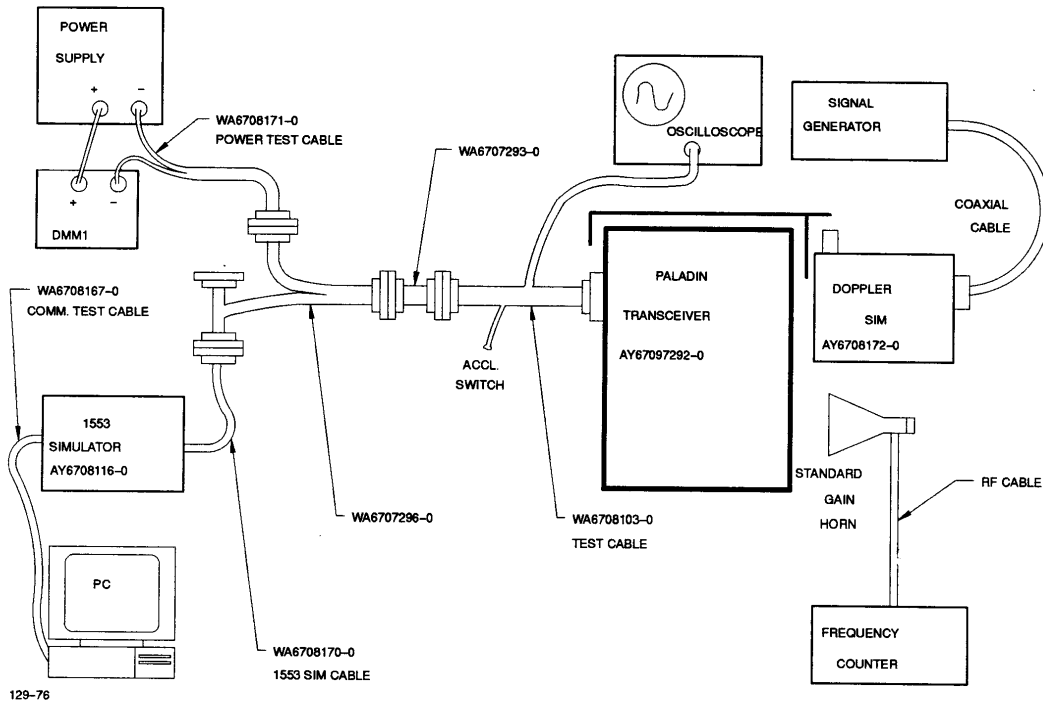

*Figure D-11. Transceiver Assembly Functional Test Setup*



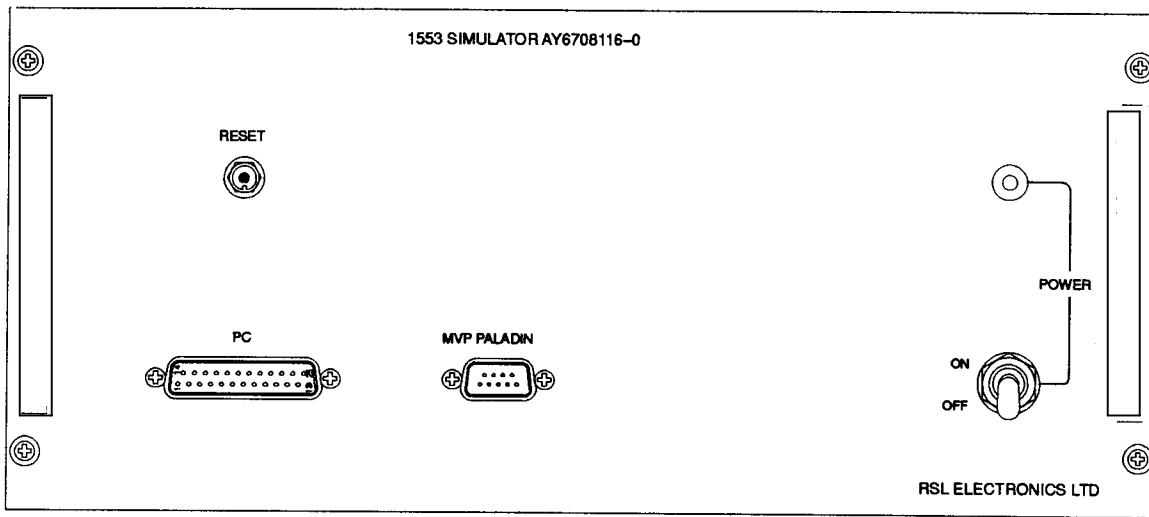

P8116

Figure D-12. 1553 Bus Simulator

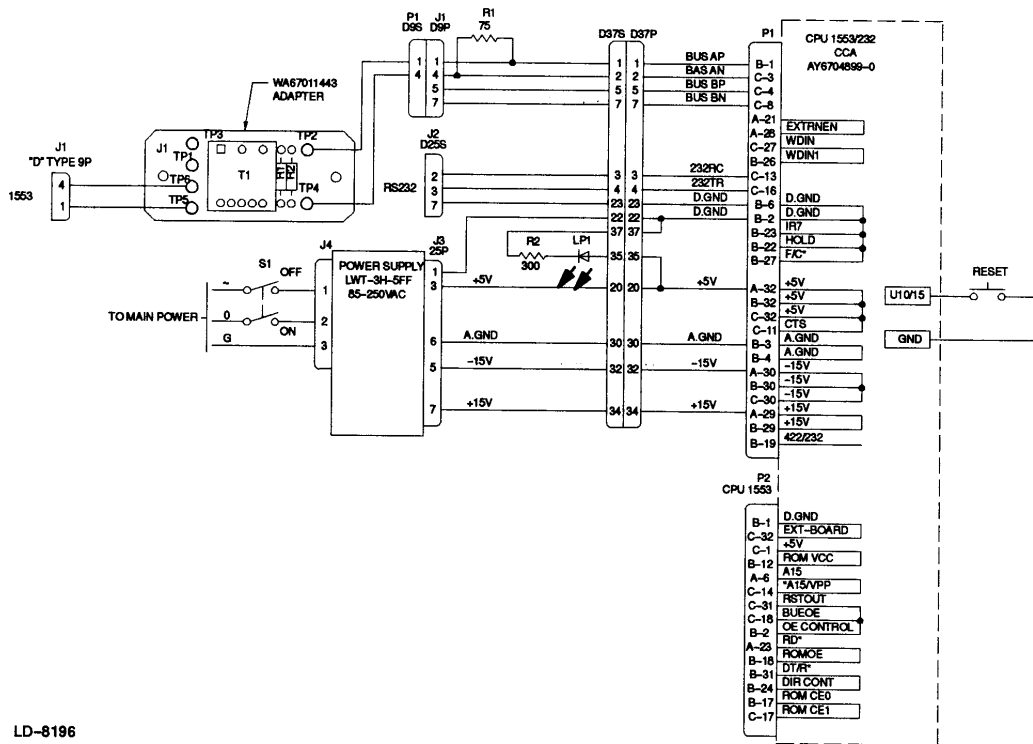

LD-8196

Figure D-13. 1553 Bus Simulator Schematic

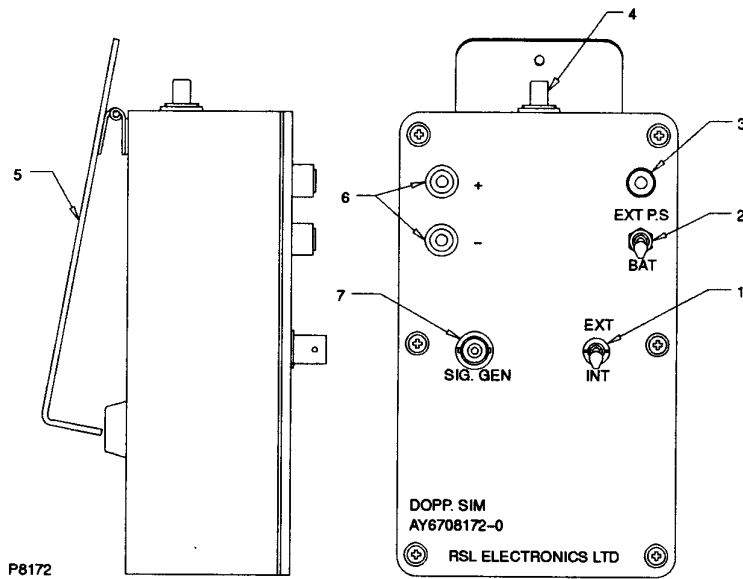

Figure D-14. Test Doppler Simulator

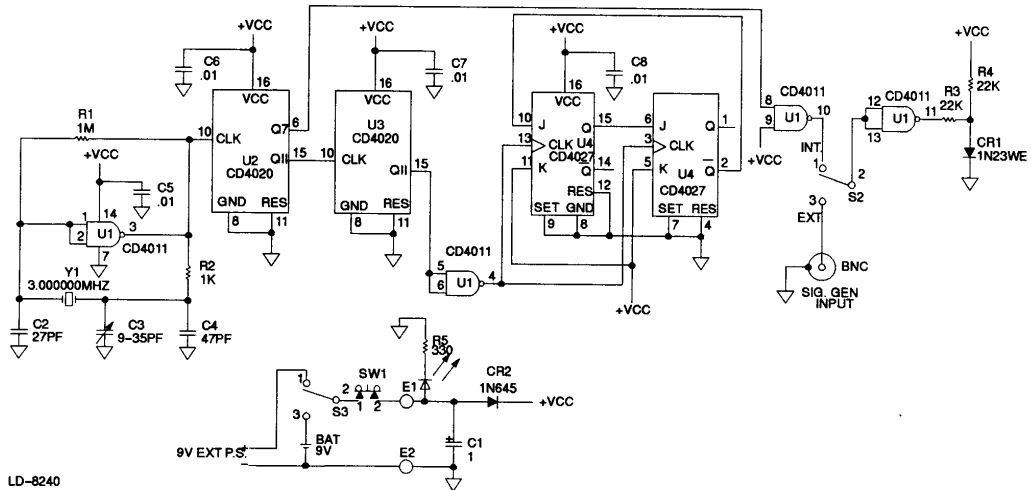

Figure D-15. Test Doppler Simulator Schematic

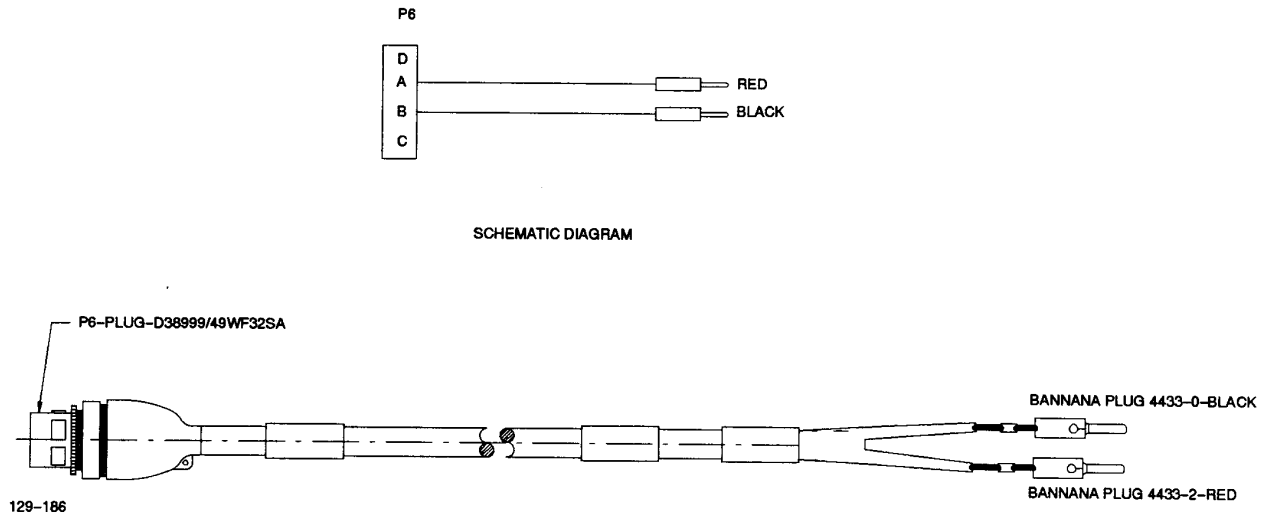

Figure D-16. Power Test Cable

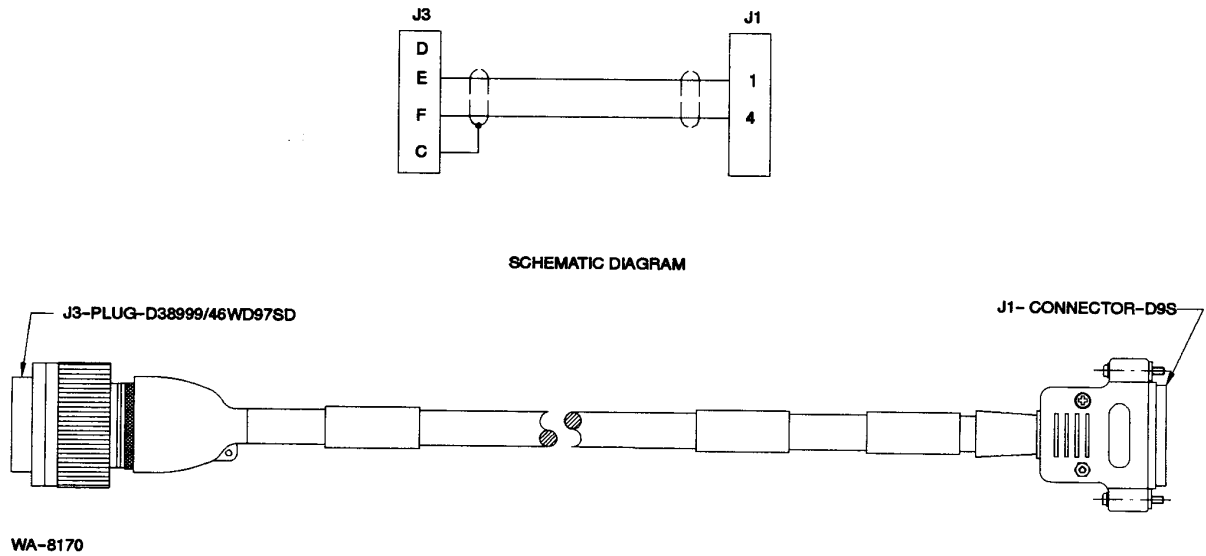
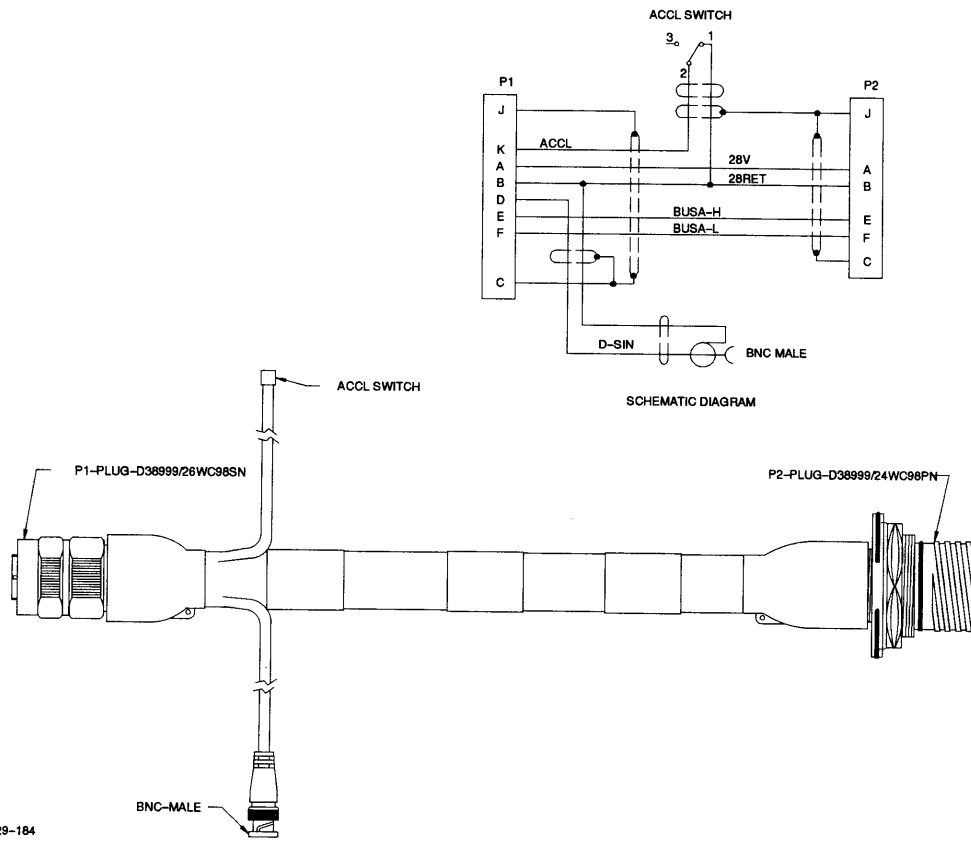
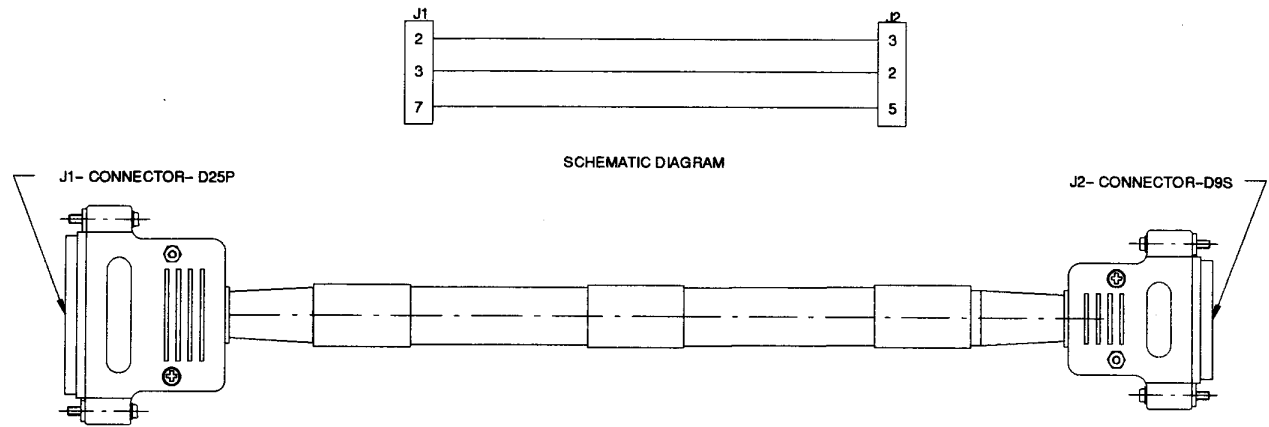

Figure D-17. 1553 Bus Simulator Cable



129-184

Figure D-18. Test Cable



129-183

Figure D-19. Communication Test Cable

**WARNING**

**Do not point the radiating surface towards any personnel. Do not bring eyes to close contact with the radiating surface. Use absorbing materials in front of the radiating surface whenever possible.**

D.4.12.3.4 2.3.4 Power Consumption Test. Refer to para. D.4.12.3 3.6 for troubleshooting procedures.

- a. Turn on the PC.
- b. Load MVS software SPC1553.EXE and run it on the PC.
- c. Turn on power supply.
- d. Verify current measure on power supply 12.350 to 300mA.

D.4.12.3 2.3.5 Transmitted Frequency and Measure Command Test. Refer to para. D.4.13.7 for troubleshooting procedures.

- a. Turn on frequency counter and set to measure a 1.70GHz frequency range.
- b. Place the standard gain horn in front of the transceiver. (Radome side pointing to the standard gain horn).
- c. Press and hold the ACCL. Switch on the test cable, for approximately 30sec and perform para. d. through h.
- d. Verify current from power supply is 500 to 700mA.
- e. Verify frequency measurement on frequency counter is 1.70525±1 MHz.
- f. Verify on the oscilloscope that the receiver noise is 0.5Vp-p to 2Vp-p.
- g. On the Test Doppler Simulator, set switch P.S.IBAT to BAT position.

**NOTE**

Adjust the Doppler Simulator on the Transceiver to get the maximum signal on oscilloscope.

- h. Verify the signal on the oscilloscope is:
  - (1) 8Vp-p minimum. The signal shape is approximately a triangle wave due to EMI filter effect.
  - (2) 455sec period.
- i. Release ACCL. Switch.
- j. Verify current from power supply is 150 to 300mA.

## ARMY TM 9-1290-365-24&P

D.4.1 2.3.6 Remote Control Test. Refer to para. D.4.12.3 3.8 for troubleshooting procedures.

### NOTE

During the test, the message "AAAA Stay Alive" may appear several times.

- a. Turn on the 1553 Simulator.
- b. Using the mouse, on the PC choose "Start" from the EVENT menu.
- c. Verify the following message on screen:  
"AAAA BIT FAILURE FALSE YYY.Y Ver X.X"  
"AAAA Stay alive"  
where: AAAA = message sequence no.  
YYY.Y = 3955 m/sec.  
X.X = last version no.
- d. Choose "BIT Status" from the EVENT menu.
- e. Verify the following message on screen:  
"AAAA BIT FAILURE FALSE YYY.Y Ver. X.X"  
Where AAAA = message sequence no.  
YYY.Y = 3955 m/sec.  
X.X = last version no.
- f. Set velocity range from the EVENT menu to: 100 m/s min, 1000 m/s max.
- g. On the Test Doppler Simulator set EXTERNAL,INTERNAL switch to EXTERNAL position.
- h. Turn on function generator and set to square wave 8Vp-p, 4Vdc offset on output, 14KHz  $\pm$ 12.3 Hz.
- i. Choose "SHELL" from the EVENT menu. Press and release the ACCL. switch on the test cable.
- j. Verify the following message on screen:  
"AAAA "Velocity YYY.Y TRUE"  
Where: AAAA = message sequence no.  
YYY.Y = 199.00.5 m/sec.
- k. Set function generator to 50KHz  $\pm$ 1Hz.
- l. Choose "SHELL" from the EVENT menu. Press and release the ACCL. switch on the test cable.
- m. Verify the following message on screen:  
"AAA VELOCITY YYY.Y TRUE"  
where: AAAA = message sequence no.  
YYY.Y = 710.90.6.
- n. Choose "SHELL" from the EVENT menu.
- o. Tap the transceiver assembly back cover using plastic hammer to activate the acceleration switch mounted on the MVP CCA.
- p. Verify the following message on screen:  
"AAA VELOCITY YYY.Y TRUE"  
where: AAAA = message sequence no.  
YYY.Y = 710.90.6.

D.4.12.3 2.3.7 Deenergize power supply. Set P.S/BAT switch on Doppler simulator to P.S. Disconnect all test equipment from transceiver.

### END-OF-TEST

Table D-6. Transceiver Assembly Functional Test Data Sheet

TRANSCIVER ASSEMBLY SER NO. \_\_\_\_\_

Para.	Required Results	Actual Results	Remarks
D.4.12.3.4d.	225 ± 75mA		
D.4.12.3.5d.	600 ± 100mA		
D.4.12.3.5e.	10,525 ± 1MHz		
D.4.12.3.5f.	0.5Vp-p to 2Vp-p noise		
D.4.12.3.5h.(1) D.4.12.3.5h.(2)	8Vp-p minimum 45 ± 5µsec		
D.4.12.3.5j.	225 ± 75mA		
D.4.12.3.6b.	"AAAA BIT FAILURE FALSE YYY.Y" Ver X.X YYY.Y - 395 ± 5 m/sec X.X last Ver. "AAAA Stay Alive"		
D.4.12.3.6c.	"AAAA BIT FAILURE FALSE YYY.Y" Ver X.X YYY.Y - 395 ± 5 m/sec X.X last Ver.		
D.4.12.3.6h.	"AAAA VELOCITY YYY.Y TRUE" 199.0 ± 0.5 m/sec		
D.4.12.3.6k.	"AAAA VELOCITY YYY.Y TRUE" 710.9 ± 0.6 m/sec		
D.4.12.3.6n.	"AAAA VELOCITY YYY.Y TRUE" 710.9 ± 0.6 m/sec		

Date: \_\_\_\_\_  
 Tested by: \_\_\_\_\_  
 Inspected by: \_\_\_\_\_

**D.4.13 Troubleshooting.** This paragraph contains the troubleshooting procedures for UUT failures detected during testing. It is arranged in the sequence of test steps, and provides information on additional test steps required for the malfunction isolation. Refer to Figure FO-1 for the interconnection diagram of the UUT.

**WARNING**

Do not point the radiating surface towards any personnel. Do not bring eyes to close contact with the radiating surface. Use absorbing materials in front of the radiating surface whenever possible.



**CAUTION**

This equipment contains assemblies subject to damage by electrostatic discharge. Use approved grounding procedures before touching, removing or inserting printed wiring assemblies.

**CAUTION**

Exercise extra caution while handling the transceiver and its electrical terminal. Use grounding strap on both hands.

**WARNING**

Deenergize all external power supplies and other test equipment when disassembling or reassembling the UUT.

**NOTE**

In all troubleshooting procedures, when additional disassembly or reassembly is required, refer to the appropriate disassembly (D.4.6) or reassembly (D.4.11) procedure.

After completion of troubleshooting and repair, perform the complete test procedure from the start.

D.4.13.1 TRANSCEIVER POWER SUPPLY FAILURES. Failure in test procedure para. D.4.12.3 12.2.3.

D.4.13.1.1 Failure in Test Procedure Para. D.4.12.3 2.2.3d, e.

- a. Remove connector P1.7 from power supply module and check for 28Vdc between pins 6 and 2 of connector P1.7. If no voltage, check wiring from connector P1 to connector P4 (pins 1 and 2).
- b. Check wiring from connector P12.3, pins 13, 12.32 to connector P4, pins 8, 9 respectively.
- c. Remove connector P2 from power supply module.
- d. Check for short circuit between pins 1.7 and 2 of connector P2. If shorted, check the connection to Doppler amplifier CCA.
- e. If not failed, test and troubleshoot power supply module IAW Section D.6.

D.4.13.1.2 Failure in Test Procedure Para. D.4.12.3 2.2.3.f.and g.

- a. Remove connector P1 from power supply module. Check wiring from connector P1, pins 15, 7, 14 to connector P4, pins 5, 7, 6 respectively. Verify no short circuit to other pins.
- b. If not failed, test and troubleshoot power supply module IAW Section D.6.

D.4.13.1.3 Failure in Test Procedure Para. D.4.12.3 2.2.3.i.

- a. Check for correct voltage (marked on the power supply module and the transceiver) on the transceiver oscillator input. If voltage is correct, replace transceiver.
- b. Remove connector P2 from power supply module.
- c. Check connector P2 pins 11 and 9 are properly connected to transceiver, and are not shorted.
- d. Check connector P2, pin 8 is properly connected to connector P4, pin 10, and is not shorted.
- e. If not failed, test and troubleshoot power supply module IAW Section D.6.

D.4.13.1.4 Failure in Test Procedure Para. D.4.12.3 2.2.3 h. and j. Test and troubleshoot power supply module IAW Section D.6.

D.4.13.2 TRANSMITTED FREQUENCY FAILURE. Failure in test procedure para. D.4.12.2.4.

- a. Repeat the test procedure. Verify proper RF frequency counter setting and calibration.
- b. If there is no frequency reading or frequency adjustment is impossible, replace transceiver.



D.4.13.3 TRANSMITTED POWER FAILURE. Failure in test procedure para. D.4.12.2.5.

- a. Repeat the test procedure. Verify proper RF power meter setting and calibration. Verify serviceable RF cables are used.
- b. If no power or power out of specified range, replace transceiver.

D.4.13.4 RECEIVER SENSITIVITY FAILURE. Failure in test procedure para. D.4.12.2.6.

D.4.13.4.1 Sensitivity below required level.

- a. Repeat the test procedure. Adjust phase shifter.
- b. If no broad band noise, test and troubleshoot Doppler amplifier CCA IAW Section D.5.
- c. Check ripple voltage of no more than 50mVp-p on transceiver oscillator input. If failed, test and troubleshoot power supply module IAW Section D.6.
- d. If broadband noise is higher than allowed, replace transceiver.
- e. Set variable attenuator to 10dB attenuation. If signal on Doppler amplifier CCA outputs is saturated, 12Vp-p or more, replace transceiver.
- f. If not failed, test and troubleshoot Doppler amplifier CCA IAW Section D.5.

D.4.13.4.2 No Sensitivity.

- a. Set variable attenuator to 30dB.
- b. Check shielded wire on Doppler amplifier input.
- c. Check ripple voltage of no more than 50mVp-p on transceiver oscillator input. If failed, test and troubleshoot power supply module IAW Section D.6.
- d. If no output noise at all, test and troubleshoot Doppler amplifier CCA IAW Section D.5.
- e. If there is some output noise, replace transceiver.

D.4.13.4.3 Signal On One Output Only. Test and troubleshoot Doppler amplifier CCA IAW Section D.5.

D.4.13.5 INTEGRATED SIMULATOR FAILURE. Failure in test procedure para. D.4.12.2.7. (For versions AY6707292-4 and AY6707292-5 only)

- a. Replace integrated simulator assembly.
- b. If failed after replacement, replace microstrip antenna.

D.4.13.6 POWER CONSUMPTION FAILURE. Failure in test procedure para. D.4.12.3.4.

D.4.13.6.1 No Current Consumption.

- a. Remove connector P3 from MVP CCA. Check for correct voltage between pins 1.3.2 and 2 of connector P3 (28Vdc). If failed, replace EMI filter module IAW Section D.8.
- b. Check for continuity between pin P12.3/ito pin P3/1, and pin P1/2 to pin P3/2, of connectors P1 and P3 of the MVP CCA. If failed, test and troubleshoot MVP CCA IAW Section D.7.

D.4.13.6.2 High Current Consumption.

- a. Remove connector P3 from MVP CCA. Check for continuity between pins 11 and 12 of connector P3 to pins H and K of J1 respectively, of EMI filter module. If failed, replace EMI filter module IAW Section D.8.
- b. Check for continuity between pins 11 and 8 of connector P3 of MVP CCA. If failed, test and troubleshoot MVP CCA IAW Section D.7.
- c. If not failed, test and troubleshoot MVP CCA IAW section D.7 for high correct consumption.

## **ARMY TM 9-1290-365-24&P**

D.4.13.7 TRANSMITTED FREQUENCY FAILURE. Failure in test procedure para. D.4.12.3.5.

- a. Remove connector P3 from MVP CCA. Check for short circuit between pins 11 and 12 of connector P3 of EMI filter module. If failed, replace EMI filter module IAW Section D.8.
- b. Check for short circuit between pins 11 and 12 of connector P3 of MVP CCA. If failed, test and troubleshoot MVP CCA IAW Section D.7.
- c. If not failed, test and troubleshoot MVP CCA IAW Section D.7.

D.4.13.8 REMOTE CONTROL FAILURE. Failure in test procedure para. D.4.12.3.6.

D.4.13.8.1 No Communication.

- a. Remove connector P3 from MVP CCA. Check for continuity, or short circuit, between pin 7 to pin E, and pin 5 to pin F, of connectors P3 and J1 of the EMI filter module. If failed, replace EMI filter module IAW Section D.8.
- b. Remove connector P4 from MVP CCA. Check for continuity between pin 26 to pin 15 on connector P4 of harness. Check for continuity between pin 8 to pins 21, 22, 24, 25 on connector P4 of harness. Check for continuity between pin 13 to pins 11,12,23, on connector P4 of harness. If failed, repair wiring.
- c. If not failed, test and troubleshoot MVP CCA IAW Section D.7.

D.4.13.8.2 Operational Failure. If failure true in test procedure para. D.4.12.3.6b or false or no measurement in test procedure para. D.4.12.6h., k., and n., test and troubleshoot MVP CCA IAW Section D.7.  
D.4.14 Final Testing.

D.4.14.1 FINAL TESTING PROCEDURES. The final testing is performed on a reassembled UUT. The test setup provided in Figure D-11., shows the equipment used and cable hookup for the first procedural step.

D.4.14.2 TEST DATA SHEETS. The test data sheets in Table D-6, are to be reproduced locally, as required, for recording the test results. The test data sheets must be completed each time a test section is performed. The completed test data sheets shall be retained.

D.4.14.3 PREPARATION FOR TEST.

- a. Reassemble the UUT IAW para. D.4.11 .9.
- b. Energize power supply and adjust for  $+28 \pm 0.5$  Vdc. Deenergize power supply.
- c. Energize and adjust DMM to measure high DC current.
- d. Place the test Doppler simulator on the transceiver antenna radome using the handle.
- e. Set test Doppler simulator switch PS/BAT to PS position.
- f. Set test Doppler simulator switch EXTERNAL/INTERNAL to INTERNAL position.
- g. Before connecting the UUT to the test setup, verify that both power supplies are deenergized.
- h. Connect the UUT to the test setup IAW Figure D-11.

D.4.14.4 FINAL TESTING. Perform the final testing IAW para. D.4.12.3.4 through D.4.12.3.7.

**SECTION V. DOPPLER AMPLIFIER CIRCUIT CARD  
ASSEMBLY (CCA), P/N AY67065566-O**

**SECTION CONTENTS**

<b>Subject</b>	<b>Page</b>
General.....	D-49
Test Equipment and Special Tools Required.....	D-49
Materials Required.....	D-50
General Repair Requirements.....	D-50
Doppler Amplifier CCA Removal.....	D-51
Cleaning.....	D-51
Visual Inspection.....	D-51
Repair.....	D-51
Painting.....	D-51
Doppler Amplifier CCA Installation.....	D-51
Testing.....	D-52
Troubleshooting.....	D-57
Final Testing.....	D-60

D.5 DOPPLER AMPLIFIER CCA, P/N AY67065566-O.

D.5.1 General. The following paragraphs provide repair procedures and maintenance information for the transceiver Doppler amplifier CCA, P/N AY67065566-O. Source, maintenance, and recoverability code is PADD.

D.5.2 Test Equipment and Special Tools Required. Test equipment and special tool requirements are listed in Table D-7. Unless otherwise specified, the test equipment and special tools listed below will be used for testing the Doppler amplifier CCA. Each commercially available item of test equipment can be replaced by equipment equivalent to that listed.

*Table D-7 Test Equipment and Special Tools Required*

<b>Nomenclature</b>	<b>Part/Spec. No.</b>	<b>Figure</b>
Coaxial Cables, BNC, Male-To-Male, 50 Ω, (4)	Local Manufacture	N/A
Digital Counter	Fluke, Model 7250A	C-11, 32
Digital Multimeter	Fluke, Model 77-2	C-11, 5
Electronic Equipment Tool Kit	PPL863	C-11, 11
Function Generator	Wavetek, Model 178	C-11, 23
Oscilloscope	Hewlett Packard, Model 1070B	C-11, 16
Power Supply, DC (0-40V, 1A)	Lambda, LLS-5040	C-11, 25
Test Set	RSL, P/N AY6708018-0	C-11, 43
ESD Work Station Kit	M87893-02	C-11, 13

## ARMY TM 9-1290-365-24&P

**D.5.3 Materials Required.** Repair materials and other consumable item requirements are listed in Table D-8.

*Table D-8. Materials Required*

Nomenclature	Part/Spec. No.	Appendix F Item No.
Adhesive	MIL-A-6146, Type III	19
Insulation Compound	MIL-I-46058 TYPE 1B31	9
Solder	SN63WRMAP3	23
Antistatic Bag	3271576	31

**D.5.4 General Repair Requirements.** Refer to Figure D-20. The following general requirements apply to the repair of the Doppler amplifier CCA.



**CAUTION**

**The Doppler amplifier CCA contains components subject to damage by electrostatic discharge (ESD). Use approved grounding procedures before touching, removing, or inserting CCA.**

- a. Ensure that components are properly oriented before installing.
- b. Square mounting pad designates:
  - (1) Pin 1 of integrated circuit
  - (2) Emitter of transistor
  - (3) Cathode of diode
  - (4) Positive lead of capacitor
- c. Do not bend leads of components L1, L2, and T1.
- d. Bond the following components to printed wiring board (PWB) with MIL-A-46146, Type III, adhesive before applying insulation compound.  
C7 C15 C21-C24 C26  
L1 L2 T1
- e. Use only SN63WRMAP3 tin/lead solder or approved equivalent.
- f. Apply uniform coating of MIL-I-46058 TYPE 1B31 insulation compound, 0.003±0.002 in. thick, where compound has been removed during CCA repairs.
- g. Do not apply insulation compound to mounting edge (1/4 inch) on either side of PWB.
- h. Do not apply insulation compound to terminals E1 through E6.

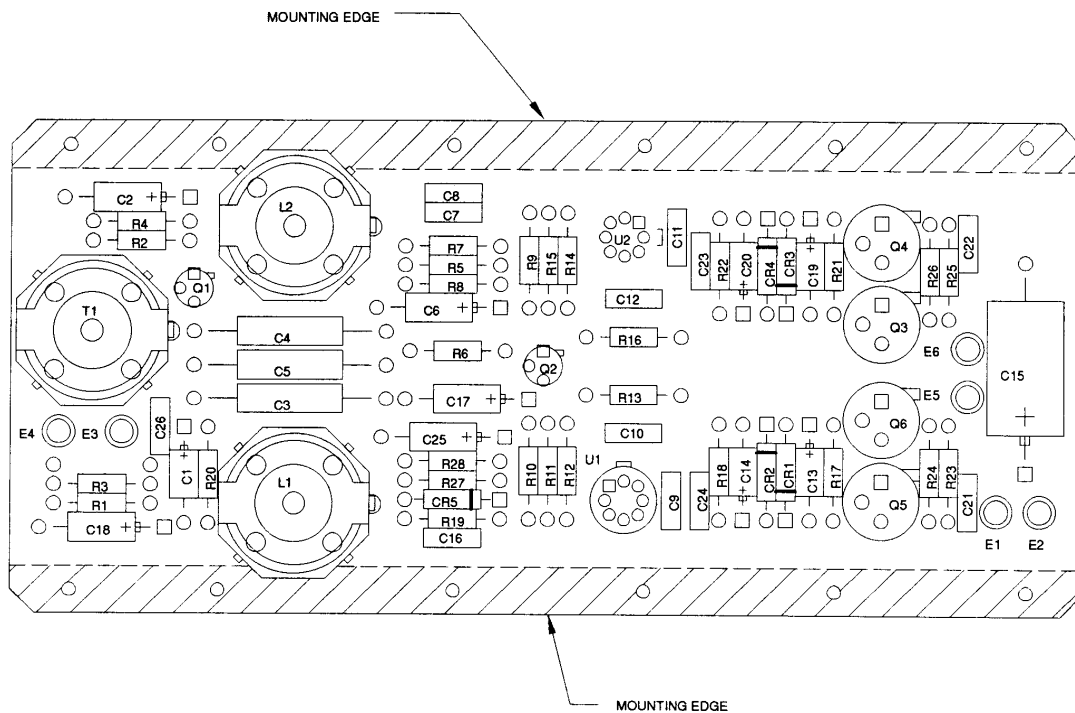

AY-6566

Figure D-20. Doppler Amplifier CCA, AY6706566-0. Components Location

**D.5.5 Doppler Amplifier CCA Removal.** Remove Doppler amplifier CCA IAW para. D.4.6.6.

**D.5.6 Cleaning.** Refer to para. 3.1.3 in Chapter 3 of this manual.

**D.5.7 Visual Inspection.** Refer to Figure D-20.

- a. Inspect all components for secure attachment.
- b. Inspect all parts for damage, wear, and deterioration.
- c. Inspect all parts for nicks, scoring, dents, scratches, and broken runs.
- d. Inspect all electronic components for indication of overheating, cracked bodies, loose terminals, broken leads, cold solder joints, and other indications of damage or deterioration.

**D.5.8 Repair.** Repair defective parts that were noticed during preshop analysis (para. D.3) and visual inspection (para. D.5.7).

**D.5.9 Painting.** No painting required on Doppler amplifier CCA.

**D.5.10 Doppler Amplifier CCA Installation.** Install Doppler amplifier CCA in transceiver assembly IAW D.4.11.4.

**ARMY TM 9-1290-365-24&P**

**D.5.11 Testing.**

**NOTE**

Hereafter, the Doppler amplifier CCA will be referred to as the unit under test (UUT).

**D.5.11.1 GENERAL.**

D.5.11 .1.1 Doppler Amplifier CCA Test Procedures. The test setup provided in Figure D-21., shows the equipment used and cable hookup for the test procedure. Figures D-22. and D-23. are detailed illustrations of the special tester.

D.5.11 .1.2 Test Data Sheets. The test data sheets in Table D-9., are to be reproduced locally, as required, for recording the test results. The test data sheets must be completed each time a test section is performed. The completed test data sheets shall be retained and used as a troubleshooting aid.

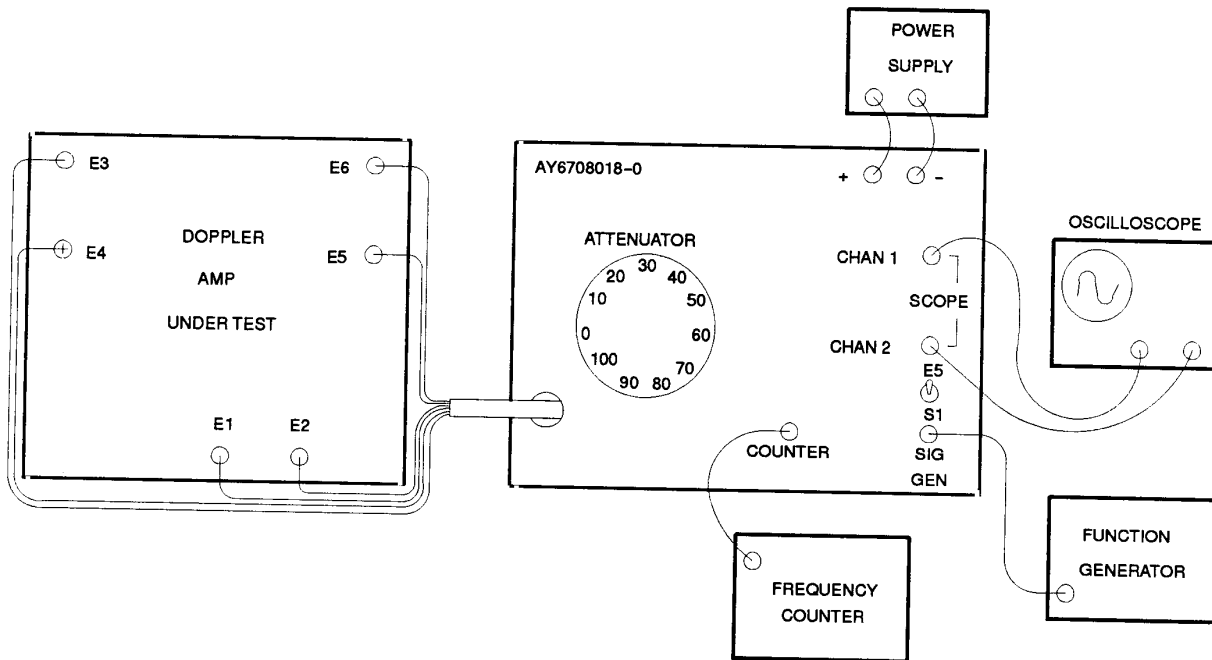

129-45

*Figure D-21 Doppler Amplifier CCA Test Setup*

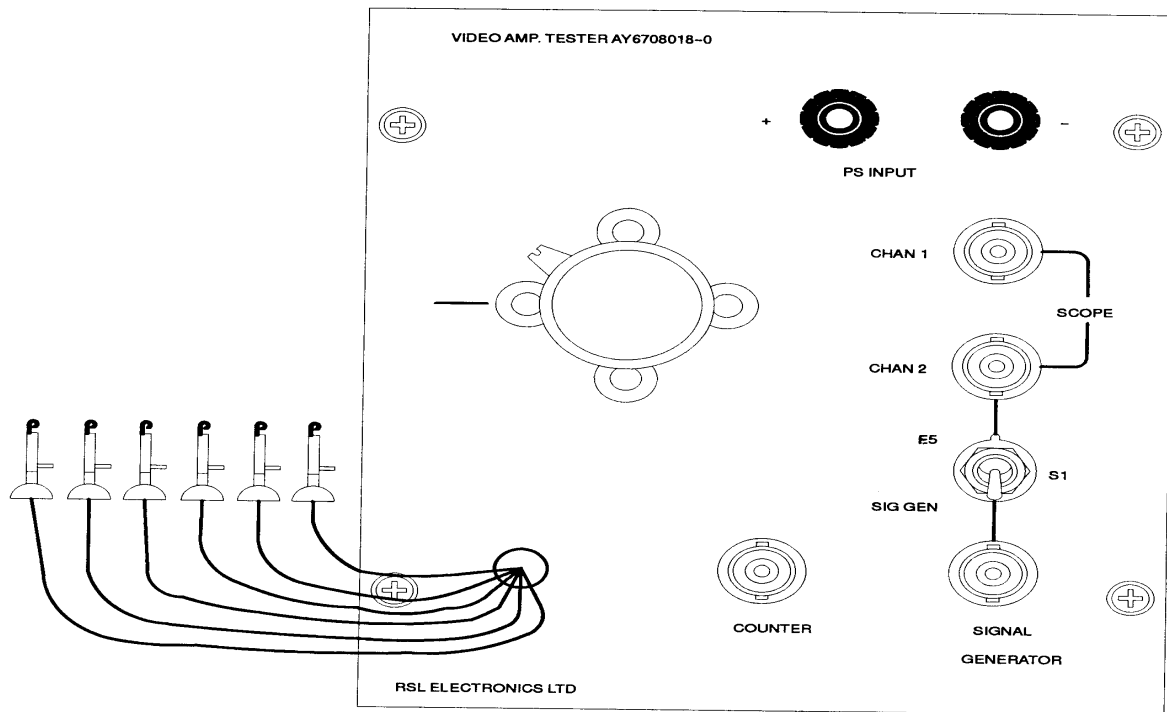

P8019

Figure D-22. Doppler Amplifier CCA Test Fixture

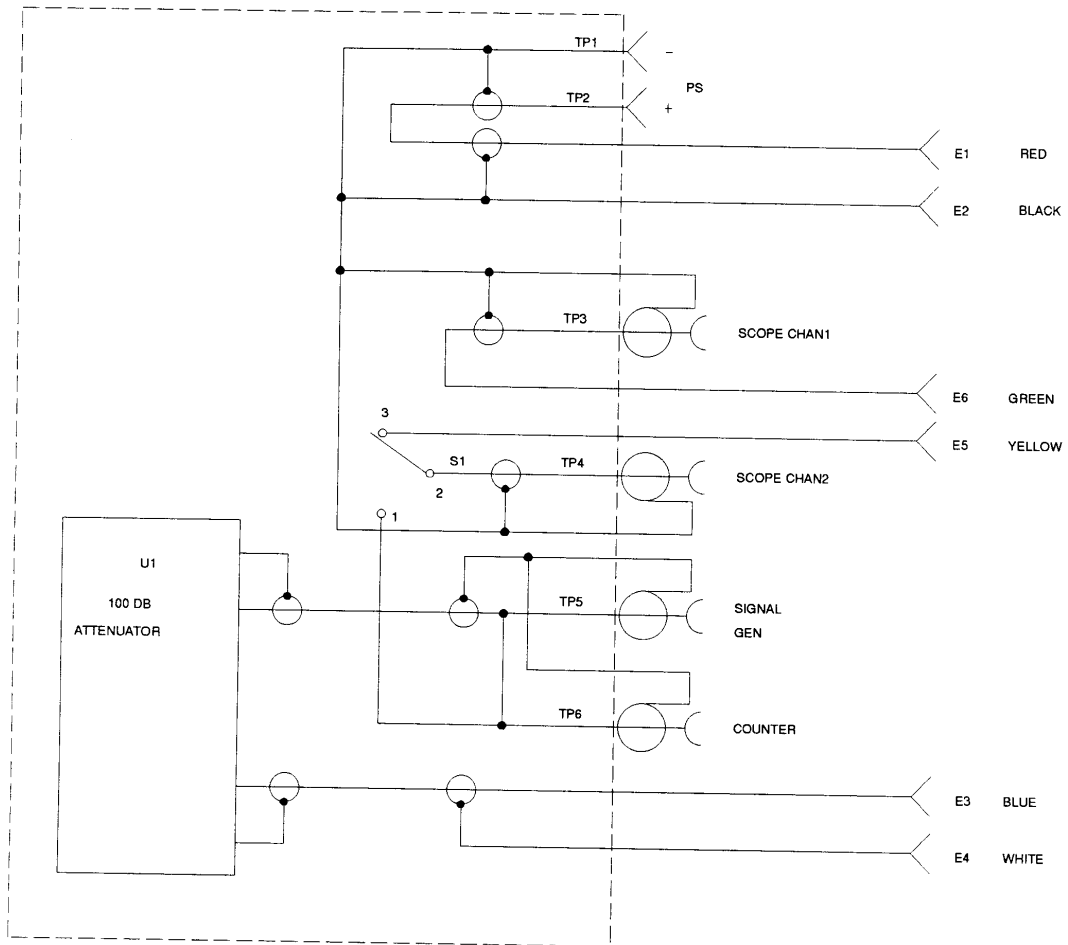

LD670-05

Figure D-23. Doppler Amplifier CCA Test Fixture Schematic



D.5.11.2 PREPARATION FOR TEST. The test setup is shown in Figure D-21. Figures D-22. and D-23. are detailed illustrations of the special tester.

- a. Remove the UUT from higher assembly IAW para. D.4.6.6.
- b. Set attenuator on the test fixture to 100dB.
- c. Energize and adjust DC power supply to measure  $+18 \pm 0.2$  Vdc. Deenergize DC power supply.
- d. Energize function generator. Set the function generator output to  $50 \pm 5$  KHz, sine wave,  $2.5 \pm 0.3$  Vp-p. Deenergize function generator.
- e. Energize scope. Set the scope as follows:
  - (1) Input Scale: 5V/cm both channels
  - (2) Time Scale: 10 $\mu$ sec/cm
  - (3) Sync Mode: Auto
  - (4) Display Mode: Alt
- f. Energize the frequency counter.
- g. Before connecting the UUT to the test setup, verify that the power supply is deenergized.
- h. Connect the UUT to the test setup IAW Figure D-21 as follows.
  - (1) Connect lead E1 (red) to test point E1 on UUT
  - (2) Connect lead E2 (black) to test point E2 on UUT
  - (3) Connect lead E3 (blue) to test point E3 on UUT
  - (4) Connect lead E4 (white) to test point E4 on UUT
  - (5) Connect lead E5 (yellow) to test point E5 on UUT
  - (5) Connect lead E6 (green) to test point E6 on UUT

D.5.11.3 FUNCTIONAL TEST.

D.5.1 1.3.1 Power source and voltage circuit test. Refer to para. D.5.12.1 for troubleshooting procedures.

- a. Energize power supply.
- b. Measure with DMM voltage between CR5/cathode and test point E2 (GND). Verify voltage is  $15 \pm 1$  Vdc.
- c. Measure with DMM voltage between C25(+) and test point E2(GND). Verify voltage is  $9 \pm 1$  Vdc.

D.5.11.3.2 Functionality Test. Refer to para. D.5.1 2.2 for troubleshooting procedures.

- a. Set switch S1 on test set to position E5. Observe on oscilloscope that a sine wave is present on both channels.
- b. Measure signal characteristics of both sine waves.
- c. Verify on channel 2 that amplitude at test point E5 is greater than 2.5Vp-p.
- d. Verify on channel 1 that amplitude at test point E6 is greater than 2.5Vp-p.
- e. Observe that signals at test points E5 and E6 are in reverse polarity to each other.

D.5.11.3.3 Maximum Output Measurement Saturation Test. Refer to para. D.5.1 2.3 for troubleshooting procedures.

- a. Disconnect clip E5 (yellow) from test point E5 of UUT. Channel 1 remains at E6 (green) clip.
- b. On test set, set switch S1 to SIGNAL GEN.

**ARMY TM 9-1290-365-24&P**

- c. Increase input amplitude by stepping attenuator in 10dB steps until CCA output is saturated. Verify that signal amplitude on channel 1 is greater than 12Vp-p.
- d. Remove clip E6 (green) from test point E6 and connect to E5.
- e. Verify CCA output is saturated. Verify signal amplitude on channel 1 is greater than 12Vp-p.

D.5.11 .3.4 Bandwidth Test. Refer to para. D.5.12.4 for troubleshooting procedures.

- a. Disconnect clip E5 from test point E5 on UUT. Channel 1 remains at E6 DOPP(-).
- b. On test set, set switch S1 to SIGNAL GEN, set attenuator to 100 dB.
- c. Turn on function generator.
- d. Verify input voltage (CHANNEL 2) is 2.5Vp-p and attenuator is set to 100 dB.
- e. Set signal frequency to 10KHz. Output readings should be equal or greater than 1.75Vp-p.
- f. Set signal frequency to 50KHz. Output reading should be equal or greater than 2.5Vp-p.
- g. Set signal frequency to 100KHz. Output readings should be equal or greater than 1.75Vp-p.
- h. Remove clip E6 (green) from test point E6 and connect to test point E5 DOPP(+).
- i. Repeat step d., e., f., and g. for DOPP(+) channel.

D.5.11 .3.5 Deenergize all test equipment and disconnect the UUT from the test fixture.

End of test

*Table D-9. Doppler Amplifier CCA Test Data Sheet*

SER. NO.: \_\_\_\_\_

Para.	Min Result	Actual Results	Max. Result	Pass/Fail	Remarks
D.5.11.3.1b.	+14Vdc		+16Vdc		
D.5.11.3.1c.	+8Vdc		+10Vdc		
D.5.11.3.2c.	2.5Vp-p				
D.5.11.3.2d.	2.5Vp-p				
D.5.11.3.2e.	Reverse Polarity				
D.5.11.3.3c.	12Vp-p				
D.5.11.3.3e.	12Vp-p				
D.5.11.3.4e.	1.75Vp-p				
D.5.11.3.4f.	2.5Vp-p				
D.5.11.3.4g.	1.75Vp-p				
D.5.11.3.4i.	1.75Vp-p 2.5Vp-p 1.75Vp-p				

Date: \_\_\_\_\_

Tested by: \_\_\_\_\_

Inspected by: \_\_\_\_\_

**D.5.12 Troubleshooting.** This paragraph contains the troubleshooting procedures for UUT failures detected during testing. It is arranged in the sequence of test steps, and provides information on additional test steps required for the malfunction isolation. Refer to Figure D-24. for additional troubleshooting information. Refer to FO-2 for schematic diagram. Refer to Figure D-20. for components location.



**CAUTION**

**The Doppler Amplifier CCA contains components subject to damage by electrostatic discharge (ESD). Use approved grounding procedures before touching, removing, or inserting CCA.**

**CAUTION**

**Deenergize all external power supplies and other test equipment when CAUTION disassembling or reassembling the UUT.**

**NOTE**

After completion of troubleshooting and repair, perform the complete test procedure from the start.

D.5.12.1 POWER SOURCE AND VOLTAGE CIRCUIT TEST FAILURE. Failure in test procedures in para. D.5.11.3.1.

- a. Verify voltage is  $15\pm 1\text{Vdc}$ . Check and replace R19 or CR5 if voltage is out of range.
- b. Verify voltage is  $9\pm 1\text{Vdc}$ . Check and replace R27 or R28 if voltage is out of range.

D.5.12.2 FUNCTIONALITY TEST FAILURE. Failure on para. D.5.11.3.2.

- a. If signal on channel 2 is low or distorted, check DOPP(+) channel. See para. D.5.12.5.
- b. If signal on channel 1 is low or distorted, check DOPP(-) channel. See para. D.5.12.6.
- c. If both channels are distorted check main channel. See para. D.5.12.7.

D.5.12.3 MAXIMUM OUTPUT MEASUREMENT SATURATION TEST FAILURE. Failure in test procedures in para. D.5.11.3.3.

- a. If signal at test point E6 is low or distorted, check DOPP(-) channel. See para. D.5.12.6.
- b. If signal at test point E5 is low or distorted, check DOPP(+) channel. See para. D.5.12.5.
- c. If both channels are not saturated, check main channel. See para. D.5.12.7.

D.5.12.4 BANDWIDTH TEST FAILURE. Failure in test procedures in para. D.5.11.3.4.

- a. If signal at test point E6 is low or distorted, check DOPP(-) channel. See para. D.5.12.6.
- b. If signal at test point E5 is low or distorted, check DOPP(+) channel. See para. D.5.12.5.
- c. If both channels are distorted, check main channel. See para. D.5.12.7.

D.5.12.5 DOPP(+) CHANNEL FAILURE. Failure in test procedures in para. D.5.12.2a., D.5.12.3b., D.5.12.4b.

- a. Check that signal at U1/6 is greater than  $2.5\text{Vp-p}$ . If signal is low or distorted, replace U1 .
- b. If high level of signal is distorted, replace Q5 and CR1 .

ARMY TM 9-1290-365-24&P

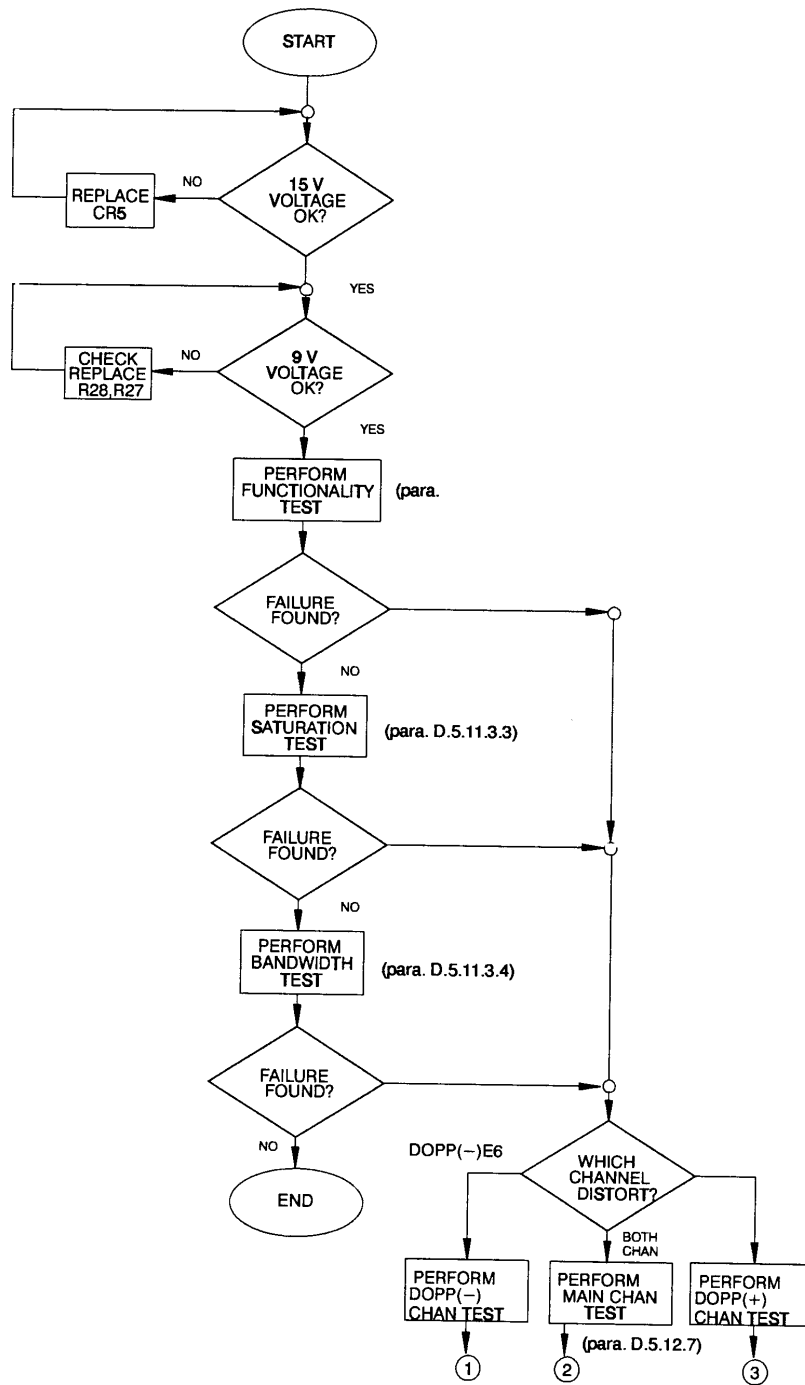

Figure D-24. Doppler Amplifier CCA, AY6706566-0, Troubleshooting Flowchart (Sheet 1 of 2)

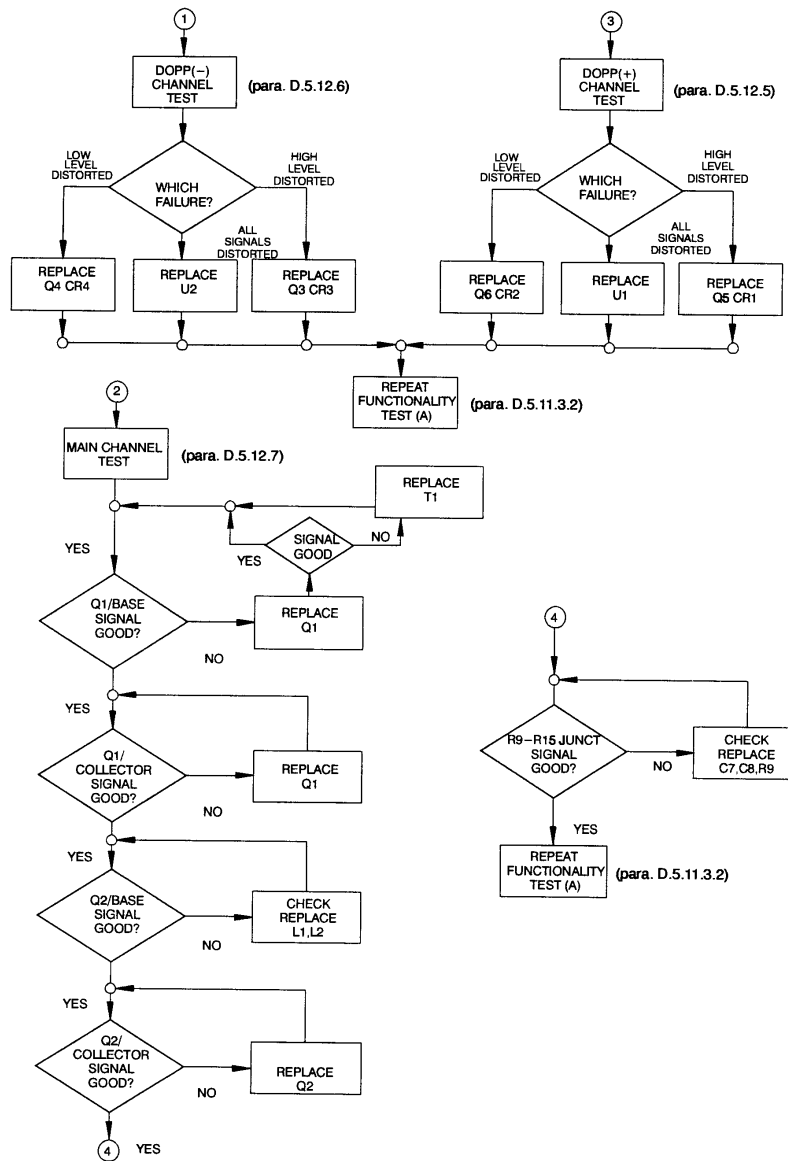

Figure D-24. Doppler Amplifier CCA, AY6706566-0, Troubleshooting Flowchart (Sheet 2 of 2)

## ARMY TM 9-1290-365-24&P

- c. If low level of signal is distorted, replace Q6 and CR2.

D.5.12.6 DOPP(-) CHANNEL FAILURE. Failure in test procedures in para. D.5.12.2b., D.5.12.3a., D.5.12.4a.

- a. Check that signal at U2/6 is greater than 2.5Vp-p. If signal is low or distorted, replace U2.
- b. If high level of signal is distorted, replace Q3 and CR3.
- c. If low level of signal is distorted, replace Q4 and CR4.

D.5.12.7 MAIN CHANNEL (STAGE 1 AND STAGE 2) FAILURE. Failure in test procedures in para. D.5.12.2c., D.5.12.3c., D.5.12.4c.

- a. Set attenuator on the test fixture to 40dB. Using oscilloscope probe, measure signal at Q1/base. If signal is distorted, replace Q1 . If signal is still distorted, replace T1 .
- b. Check signal at Q1/collector. Verify a signal gain of 100 minimum. Replace Q1 if necessary.
- c. Check signal at Q2/base. If signal is low or distorted, check and replace L1, L2, one at a time.
- d. Check the signal at Q2/collector. Verify a gain of 40 minimum (Q2/base to Q2/collector). Set attenuator on test fixture to higher attenuation if signal is saturated. Replace Q2 if necessary.
- e. Check signal at R9, R15 junction. If signal is low or distorted replace C7, C8. R9.

### D.5.13 Final Testing.

D.5.13.1 FINAL TESTING PROCEDURES. This paragraph contains the final testing procedures. The test setup provided in Figure D-21 . shows the equipment used and cable hookup for the first procedural step.

D.5.13.2 TEST DATA SHEETS. The test data sheets in Table D-9. are to be reproduced locally, as required, for recording the test results. The test data sheets must be completed each time a test section is performed. The completed test data sheets shall be retained.

D.5.13.3 PREPARATION FOR TEST.

- a. Set attenuator on the test fixture to 100dB.
- b. Energize and adjust DC power supply to measure  $+18 \pm 0.2\text{Vdc}$ . Deenergize DC power supply.
- c. Energize function generator. Set the function generator output to  $50 \pm 5\text{KHz}$ , sine wave,  $2.5 \pm 0.3\text{Vp-p}$ . Deenergize function generator.
- d. Energize scope. Set the scope as follows:
  - (1) Input Scale: 5V/cm both channels
  - (2) Time Scale: 1 10 $\mu\text{sec/cm}$
  - (3) Sync Mode: Auto
  - (4) Display Mode: Alt
- e. Energize the frequency counter.
- f. Before connecting the UUT to the test setup, verify that the power supply is deenergized.
- g. Connect the UUT to the test setup IAW Figure D-21 . as follows:
  - (1) Connect lead E1 (red) to E1 on UUT
  - (2) Connect lead E2 (black) to E2 on UUT
  - (3) Connect lead E3 (blue) to E3 on UUT
  - (4) Connect lead E4 (white) to E4 on UUT

**ARMY TM 9-1290-365-24&P**

- (5) Connect lead E5 (yellow) to E5 on UUT
- (6) Connect lead E (green) to E6 on UUT

D.5.13.4 FINAL TESTING. Perform the final testing IAW para. D.5.11 .1.2.





**SECTION VI. POWER SUPPLY MODULE, P/N AY6707291-0**

**SECTION CONTENTS**

<b>Subject</b>	<b>Page</b>
General.....	D-63
Test Equipment and Special Tools Required.....	D-63
Materials Required .....	D-64
General Repair Requirements .....	D-64
Power Supply Module Disassembly.....	D-65
Cleaning .....	D-65
Visual Inspection .....	D-65
Repair.....	D-68
Painting .....	D-68
Power Supply Module Reassembly .....	D-68
Testing.....	D-69
Troubleshooting .....	D-76
Final Testing.....	D-78

**D.6 POWER SUPPLY MODULE, P/N AY6707291-0.**

**D.6.1 General.** This section provides repair procedures and maintenance information for the power supply module, P/N AY6707291-0 Source, maintenance, and recoverability code is PADDD.

**D.6.2 Test Equipment and Special Tools Required.** Test equipment and special tools requirements are listed in Table D-10. Unless otherwise specified, the test equipment and special tools listed below will be used for testing the power supply module. Each commercially available item of test equipment can be replaced by equipment equivalent to that listed.

*Table D-10. Test Equipment and Special Tools Required*

Nomenclature	Part/Spec. No.	Figure
CoaxialCables,BNC,Male-to-Male,50 ohm	Local Manufacture	N/A
Digital Multimeter	Fluke, Model 77-2	C-11, 5
Digital Multimeter	Hewlett Packard, Model 3478A	C-11, 33
Electronic Equipment Tool Kit	PPL863	C-11, 11
Power Supply, DC (0-40V, 5A)	Lambda, LLS-9040	C-11, 24
Oscilloscope	Hewlett Packard, Model 1070B	C-11, 17
Test Set, Paladin Power Supply	RSL, PIN AY6707046-0	C-11, 44
ESD Work Station Kit	M87893-02	C-11, 13

## ARMY TM 9-1290-365-24&P

**D.6.3 Materials Required.** Repair materials and other consumable items required are listed in Table D-11.

Table D-11. Materials Required

Nomenclature	Part/Spec. No.	Appendix F Item No.
Resistor	See table D-13	TBD
Adhesive	MIL-A-46146, Type III	19
Insulation Compound	MIL-I-46058 TYPE 1B31	9
Solder	SN63WRMAP3	23
Lacing Tape	MIL-T-43435-B3/BLK	11
Sealing Compound	83-31	16
Primer	747-55	17
Silicone Compound	MIL-C-47113	32
Epoxy Ink	Color Black, MIL-I-43553, Type II	33
Antistatic Bag	3271576	31

D.6.4 General Repair Requirements. Refer to figure D-25. The following general requirements apply to the repair of the power supply module .



### CAUTION

**The power supply module contains components subject to damage by electrostatic discharge (ESD). Use approved grounding procedures before touching, removing, or inserting circuit card assembly (CCA).**

- a. Ensure that components are properly oriented before installing.
- b. Square mounting pad designates:
  - (1) Pin 1 of integrated circuit
  - (2) Emitter of transistor
  - (3) Cathode of diode
  - (4) Positive lead of capacitor
- c. Do not bend leads of components Q1, Q3, Q4, T3, and T4.
- d. Tie components C4, C12, C33, C43, C54, C77, C85 using MIL-T- 43435-B3 lacing tape.
- e. Bond all capacitors, transformers and chokes to printed wiring board (PWB) with MIL-A-46146, Type III, adhesive before applying insulation compound.
- f. Use only SN63WRMAP3 tin/lead solder or approved equivalent.

### CAUTION

**Insulation compound must not be applied to any connector pins. Inadvertent application of compound to connector pins may require replacement of connector.**

- g. Apply uniform coating of MIL-I-46058 TYPE 1B31 insulation compound 0.003±0.002 in. thick, where compound has been removed during CCA repairs.

- h. Do not apply insulation compound to 7 mounting holes on either side of PWB, or to the bottom of 3 TO-247 heatsinks.
- i. Apply silicon compound per MIL-C-47113 between Q1, Q3, Q4 and heatsink, and between heatsink and cover.
- j. Connectors shall be mounted flush to board. No angle allowed.
- k. Apply primer MIL-S-22473 grade T and sealing compound MIL-S-22473 grade CV to threads.
- l. If output voltage is readjusted, remove the previous marking and mark the new voltage.

**D.6.5 Power Supply Module Disassembly.**

D.6.5.1 REMOVAL. If necessary, remove power supply module IAW para. D.4.6.7.

**NOTE**

Disassemble power supply module only to the extent necessary to perform the required maintenance task.

D.6.5.2 POWER SUPPLY MODULE DISASSEMBLY. Refer to Figure D-25.

- a. Remove four spacers (9) from cover (7).
- b. Remove seven nuts (3), seven lock washers (4), and seven flat washers (5) from CCA (1).
- c. Remove six screws (6) from cover (7).
- d. Separate CCA (1) from cover (7).

D.6.5.3 TO-S HEATSINK DISASSEMBLY. Refer to Figure D-25.

- a. Remove screw (14) and flat washer (15).
- b. Remove heat sink (11) and insulator (12) from CCA (1).
- c. Using soldering iron, unsolder three leads of TO-5 component (10) from CCA (1).
- d. Remove TO-5 component (10) and insulator (13) from CCA (1).

D.6.5.4 TO-247 HEATSINK DISASSEMBLY Refer to Figure D-25.

- a. Using soldering iron, unsolder three (or six, depending on heatsink) leads of TO-247 component (20) from CCA (1).
- b. Remove two screws (17) and two flat washers (18).
- c. Remove heatsink (16) from CCA (1).
- d. Remove screw (21), lock washer (22), and flat washer (23) from TO-247 component (20).
- e. Remove TO-247 component (20) from heatsink (16).

**D.6.6 Cleaning.** Refer to para. 3.1.3 in Chapter 3 of this manual.

**D.6.7 Visual Inspection.** Refer to Figure D-25.

- a. Inspect connectors for damaged pins and foreign matter.
- b. Inspect all components for secure attachment.
- c. Inspect all parts for damage, wear, and deterioration.
- d. Inspect all parts for nicks, scoring, dents, scratches, and broken runs.
- e. Inspect all electronic components for indication of overheating, cracked bodies, loose terminals, broken leads, cold solder joints, and other indications of damage or deterioration.

ARMY TM 9-1290-365-24&P

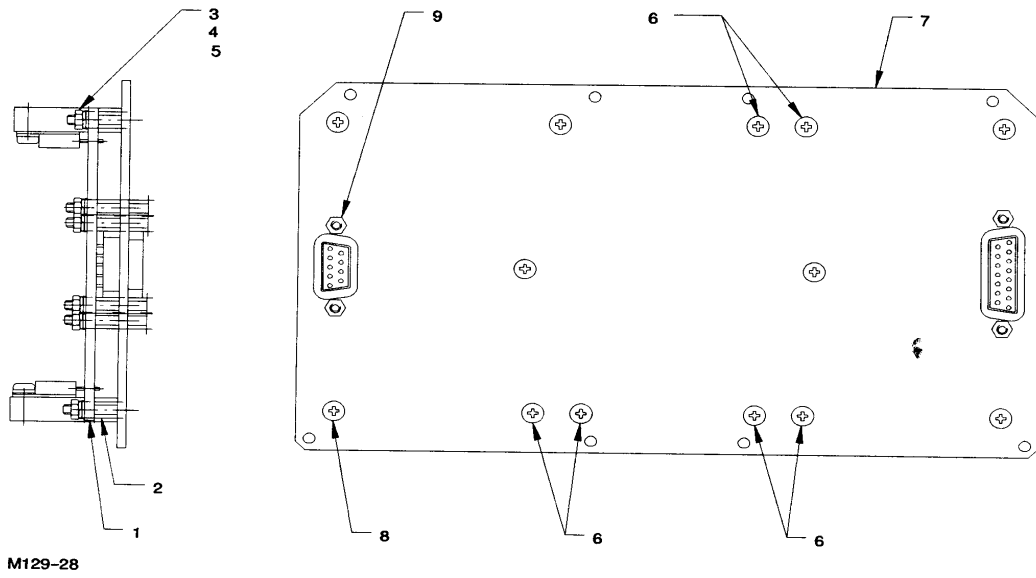

Figure D-25. Power Supply Module (Sheet 1 of 3)

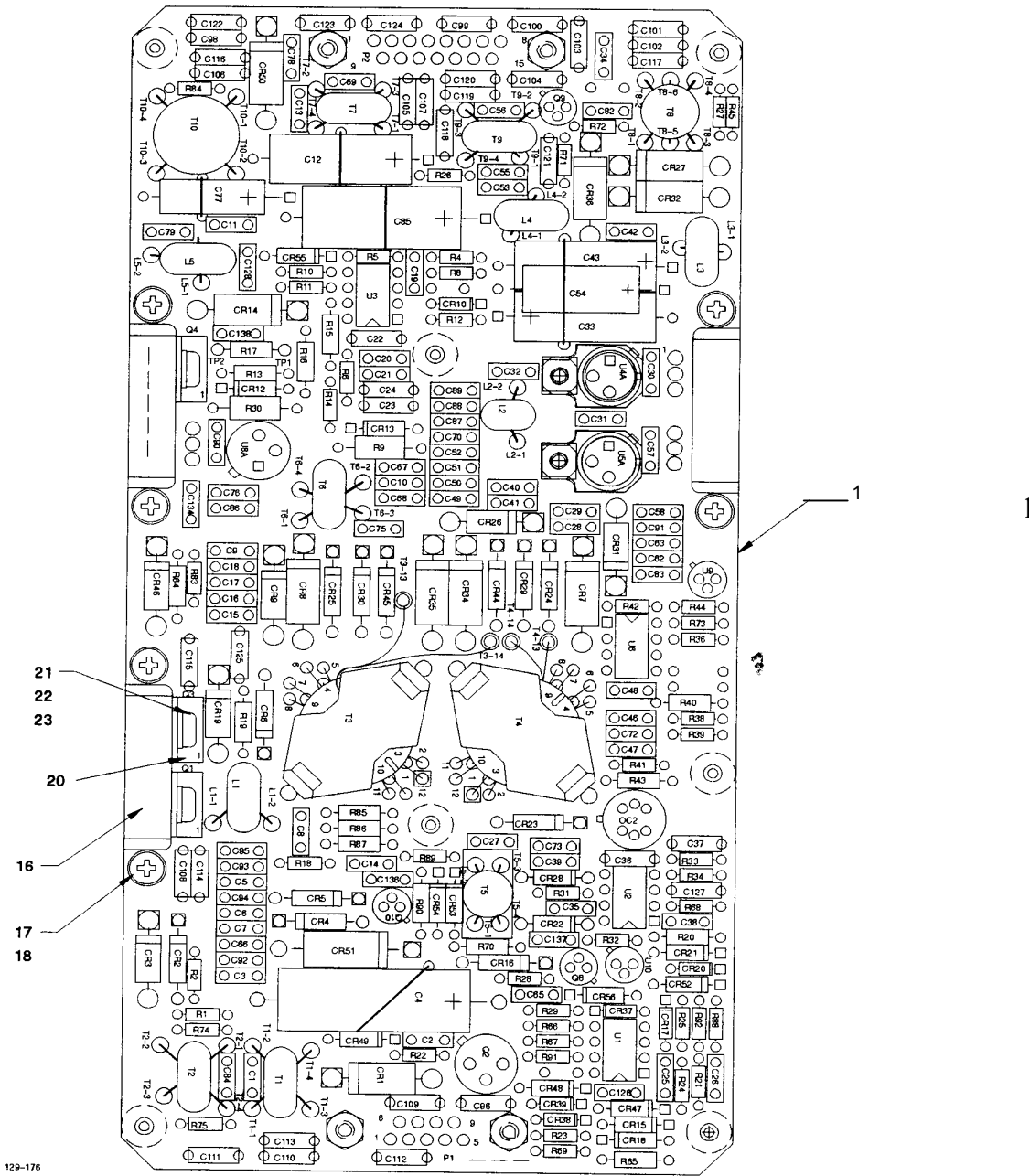

Figure D-25. Power Supply Module (Sheet 2 of 3)

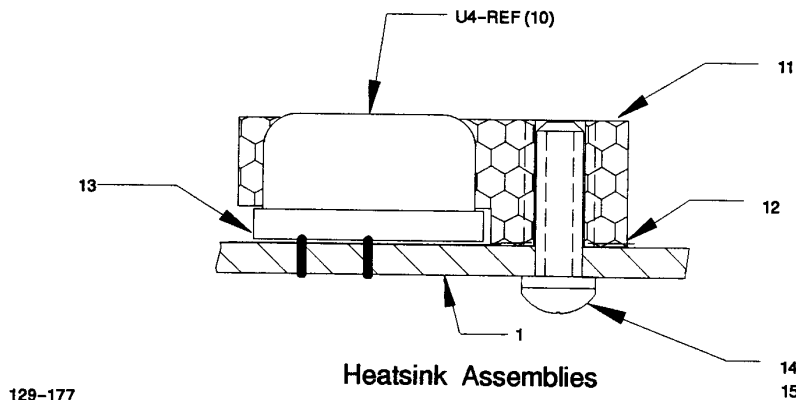

Figure D-25. Power Supply Module (Sheet 3 of 3)

**D.6.8 Repair.** Repair defective parts that were noticed during preshop analysis (para. D.3) and visual inspection (para. D.6.7).

**D.6.9 Painting.** No painting required on power supply module.

**D.6.10 Power Supply Module Reassembly.**

D.6.10.1 TO-247 HEATSINK REASSEMBLY Refer to Figure D-25.

- a. Install and fasten screw (21), lock washer (22) and flat washer (23) through TO-247 component (20) onto heatsink (16).
- b. Install heatsink (16) with components on CCA (1).
- c. Install and fasten two screws (17) and two flat washers (18).
- d. Using soldering iron, solder three (or six, depending on heatsink) leads of TO-247 component (20) to CCA (1).

D.6.10.2 TO-5 HEATSINK REASSEMBLY Refer to Figure D-25.

- a. Place TO-5 component (10) and insulator (13) on OCA (1).
- b. Using soldering iron, solder three leads of TO-5 component (10) to OCA (1).
- c. Install heatsink (11) and insulator (12) on TO-5 component (10).
- d. Install and fasten screw (14) and flat washer (15).

D.6.10.3 POWER SUPPLY MODULE REASSEMBLY Refer to Figure D-25.

- a. Place CCA (1) on cover (7).
- b. Install and fasten six screws (6) on cover (7).
- c. Install and fasten seven nuts (3), seven lock washers (4), and seven flat washers (5) on CCA (1).
- d. Install and fasten four spacers (9) on cover (7).

D.6.10.4 INSTALLATION.

- a. If necessary, perform adjustment IAW para. D.6.11.4.
- b. Install power supply module IAW para. D.4.11.3.

**D.6.11 Testing.****CAUTION**

**The power supply module contains components subject to damage by electrostatic discharge. Use approved grounding procedures before touching, removing, or inserting CCA.**

**NOTE**

Hereafter, the power supply module will be referred to as the Unit Under Test (UUT).

**D.6.11.1 GENERAL.**

**D.6.11.1.1 Power Supply Module Test Procedures.** The test setup provided in Figure D-26. shows the equipment used and cable hookup for the test procedure. Figures D-27. and D-28. are detailed illustrations of the special testers.

**D.6.11.1.2 Test Data Sheets.** The test data sheets in Table D-12., are to be reproduced locally, as required, for recording the test results. The test data sheets must be completed each time a test section is performed. The completed test data sheets shall be retained and used as a troubleshooting aid.

**D.6.11.2 PREPARATION FOR TEST.** The test is conducted on a disassembled UUT. The test setup is shown in Figure D-26. Figures D-27. and D-28. are detailed illustrations of the special testers.

- a. Remove the UUT from higher assembly IAW para. D.4.6.7.
- b. Energize and adjust digital multimeter DMM1 to measure DC volts.
- c. Energize and adjust DMM2 to measure high DC current (IOAmp).
- d. Set switch S1 on the test fixture to PS position.
- e. Set ANT S.D switch on the test fixture to OFF position.
- f. Energize and adjust DC power supply to measure  $+28 \pm 1$  Vdc. Deenergize DC power supply.
- g. Before connecting the UUT to the test setup, verify that the DC power supply is deenergized.
- h. Connect the UUT to the test setup IAW Figure D-26.

**D.6.11.3 FUNCTIONAL TEST** The purpose of this test is to certify and verify that the tested unit is working without failure. This test is performed whenever calibrating and/or after repairing the power supply (CCA or module).

**D.6.11.3.1 +5V Output Test.** Refer to para. D.6.12.1 for troubleshooting procedures.

- a. Energize all test equipment.
- b. Set switch S1 to position +5V.
- c. Verify voltage measurement on DMM1 is  $5 \pm 0.1$  Vdc.
- d. Measure the ripple with the oscilloscope in AC mode. Verify ripple on oscilloscope is less than 50m Vp-p.
- e. Verify current measurement on DMM2 is  $850 \pm 200$  mA.

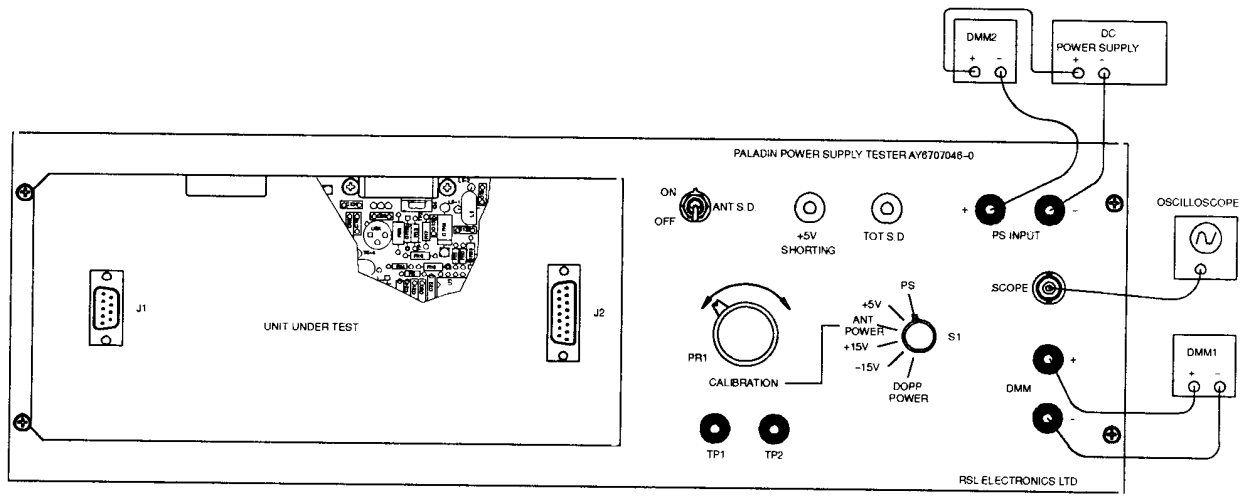
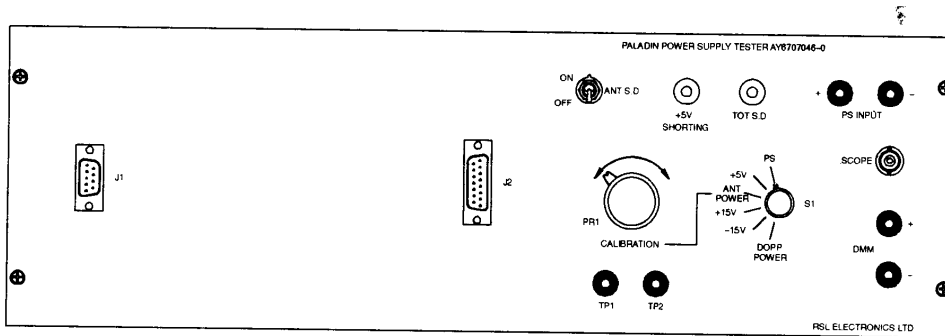

Figure D-26. Power Supply Module Test Setup



M129-188

Figure D-27. Power Supply Module Test Fixture



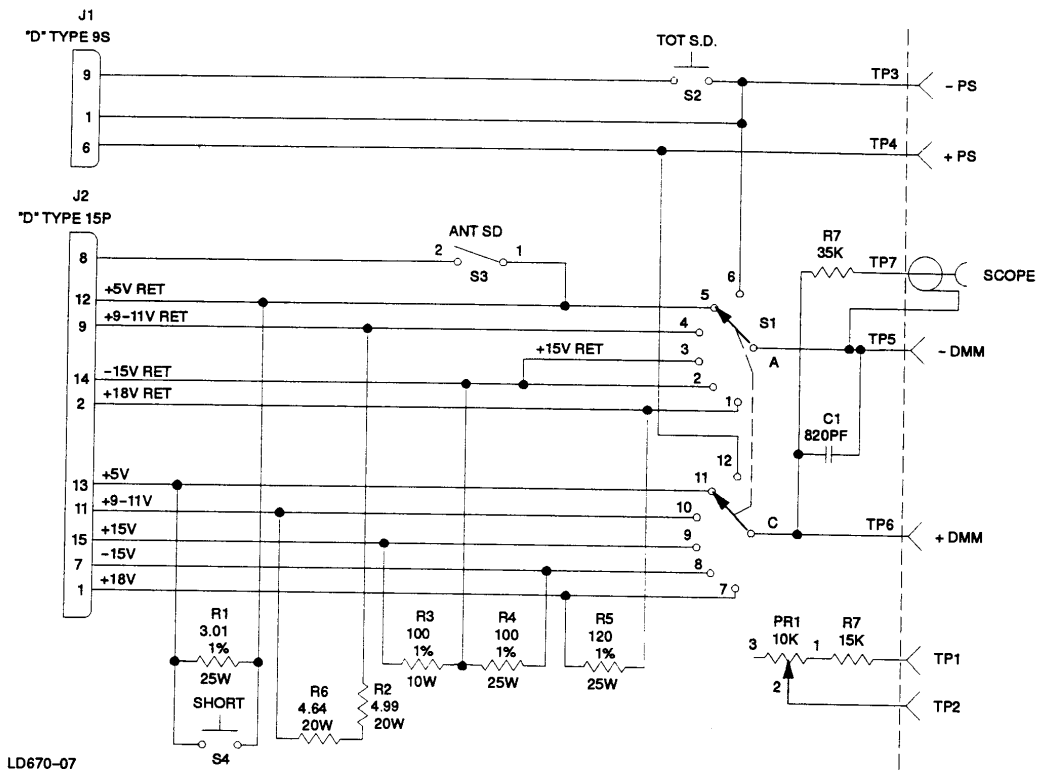

Figure D-28. Power Supply Module Test Fixture Schematic

D.6.11.3.2 Antenna Power Output Test. Refer to para. D.6.12.2 for troubleshooting procedures.

- a. Turn ON ANT.SD switch.
- b. Set switch S1 in position ANT POWER.
- c. Verify voltage measure in DMM1 is  $V \pm 0.1Vdc$ . Where V is the voltage indicated on the power supply module.
- d. With the oscilloscope in AC mode, measure the ripple. Verify that ripple on the oscilloscope is less than  $50mVp-p$ .
- e. Verify current measure on DMM2 is  $1400 \pm 300mA$ .
- f. Turn off ANT.SD switch. Verify voltage drops to  $0 \pm 0.1Vdc$ .

D.6.11.3.3 +15V Output Test. Refer to para. D.6.12.3 for troubleshooting procedures.

- a. Set switch S1 in position +15V.
- b. Verify voltage measure on DMM1 is  $15 \pm 0.2Vdc$ .
- c. With oscilloscope in the AC mode, measure the ripple. Verify ripple on oscilloscope is less than  $50mVp-p$ .

D.6.11.3.4 -15V Output Test. Refer to para. D.6.12.4 for troubleshooting procedures.

- a. Set switch S1 in position -15V.

## **ARMY TM 9-1290-365-24&P**

- b. Verify voltage measure on DMM1  $-15\pm 0.2\text{Vdc}$ .
- c. Measure the ripple with oscilloscope on AC mode. Verify ripple on oscilloscope is less than  $50\text{mVp-p}$ .

D.6.11.3.5 Doppler Power Output Test. Refer to para. D.6.12.5 for troubleshooting procedures.

- a. Set switch S1 to position DOPP POWER.
- b. Verify voltage measurement on DMM1 is  $18\pm 0.2\text{Vdc}$ .
- c. Measure the ripple with oscilloscope on AC mode. Verify ripple on oscilloscope is less than  $50\text{mVp-p}$ .

D.6.11.3.6 Shutdown Test. Refer to para. D.6.12.6 for troubleshooting procedures.

- a. Momentarily push TOT.SD button. Verify voltage drops to  $0 \pm 0.1\text{Vdc}$ .
- b. Using DMM, check that voltage on transistor Q2/gate is  $+5\pm 1\text{Vdc}$ .

D.6.11.3.7 Reverse Polarity Protection Test. Refer to para. D.6.1 2.7 for troubleshooting procedures.

- a. Measure  $1 \pm 0.3\text{Vdc}$  over diode CR1.
- b. Turn off power supply. Set switch S1 in position +5V.
- c. Connect power supply in the opposite polarity:
  - Positive lead to PS -.
  - Negative lead to PS+.
- d. Turn on power supply.
- e. Verify voltage measurement in DMM1 is  $0\pm 0.10\text{Vdc}$ .
- f. Turn off power supply.
- g. Connect power supply to correct polarity:
  - Positive lead to PS+.
  - Negative lead to PS -.

D.6.11.3.8 Operating Range Test. Refer to para. D.6.12.8 for troubleshooting procedures.

- a. Turn on power supply.
- b. Verify voltage measurement in DMM1 is  $5\pm 0.1\text{Vdc}$ .
- c. Decrease voltage in power supply until voltage on DMM1 drops to  $0\pm 0.1\text{Vdc}$ .
- d. Set switch S1 to position PS. Verify the voltage measured on DMM1 is  $15 \pm 1\text{Vdc}$ .
- e. Set switch S1 to position +5V.
- f. Increase voltage in power supply until voltage reads  $5\pm 0.1\text{Vdc}$ .
- g. Set switch Si to PS position. Verify the voltage measure on DMM1 is  $16\pm 1\text{Vdc}$ .
- h. Increase the power supply voltage up to  $28\pm 0.1\text{Vdc}$ .

D.6.11.3.9 Short Circuit Test. Refer to para. D.6.12.9 for troubleshooting procedures.

- a. Set switch S1 to position +5V.
- b. Momentarily push +5V SHORTING button. Verify current in DMM2 drops to  $(0\pm 0.1)\text{mA}$ .
- c. Release +5V SHORTING button. Set switch S1 to position +5Vdc.
- d. Verify voltage measured on DMM1 is  $5\pm 0.1\text{Vdc}$ .

D.6.11.3.10 Deenergize all test equipment.

END OF TEST

Table D-12. Power Supply Module Test Data Sheet

SER. NO. OF MODULE: \_\_\_\_\_ VOLTAGE OF MODULE: \_\_\_\_\_

Para.	Min Result	Actual Results	Max. Result	Pass/Fail	Remarks
D.6.11.3.1c.	+4.9Vdc		+5.1Vdc		
D.6.11.3.1d.	O		50mVp-p		
D.6.11.3.1e.	650mA		1050mA		
D.6.11.3.2c.	V-0.1Vdc		V+0.1Vdc		
D.6.11.3.2d.	O		50mVp-p		
D.6.11.3.2e	1100mA		1700mA		
D.6.11.3.2.f	-0.1Vdc		+0.1Vdc		
D.6.11.3.3b.	+14.8Vdc		15.2Vdc		
D.6.11.3.3c.	O		50mVp-p		
D.6.11.3.4b.	-15.2Vdc		-14.8Vdc		
D.6.11.3.4c.	O		50mVp-p		
D.6.11.3.5b.	+17.8Vdc		18.2Vdc		
D.6.11.3.5c.	O		50mVp-p		
D.6.11.3.6a.	-0.1Vdc		+0.1Vdc		
D.6.11.3.6b.	+4Vdc		+6Vdc		
D.6.11.3.7a	0.7Vdc		1.3Vdc		
D.6.11.3.7e.	-0.1Vdc		+0.1Vdc		
D6.11.3.8b	+4.9Vdc		+5.1Vdc		
D.6.11.3.8d.	14Vdc		16Vdc		
D.6.11.3.8g	15Vdc		17Vdc		
D.6.11.3.9b.	-0.1mA		+0.1mA		
D.6.11.3.9d.	+4.9Vdc		+5.1Vdc		

Date: \_\_\_\_\_  
 Tested by: \_\_\_\_\_  
 Inspected by: \_\_\_\_\_

**D.6.11.4 ADJUSTMENT PROCEDURE.**

D.6.11.4.1 PREPARATION FOR TEST. The test is conducted on a disassembled UUT. The test setup is shown in Figure D-29. Figures D-27. and D-28. are detailed illustrations of the special testers.

- a. Remove the UUT from higher assembly IAW para. D.4.6.7.
- b. Using soldering iron, remove resistors R16 and R17 from the CCA.
- c. Energize and adjust DMM1 to measure resistance.
- d. Connect DMM1 to points TP1 and TP2 on the test fixture, and adjust PR1 potentiometer to 17.5KOhm.
- e. Adjust DMM1 to measure DC volts.
- f. Energize and adjust DMM2 to measure high DC current (10 Amp).

**ARMY TM 9-1290-365-24&P**

- g. Set switch S1 on the test fixture to PS position.
- h. Set ANT S.D. switch on the test fixture to OFF position.
- i. Energize and adjust DC power supply to measure  $+28 \pm 10$  Vdc. Deenergize DC power supply.
- j. Before connecting the UUT to the test setup, verify that the DC power supply is deenergized.
- k. Connect the UUT to the test setup IAW Figure D-29.

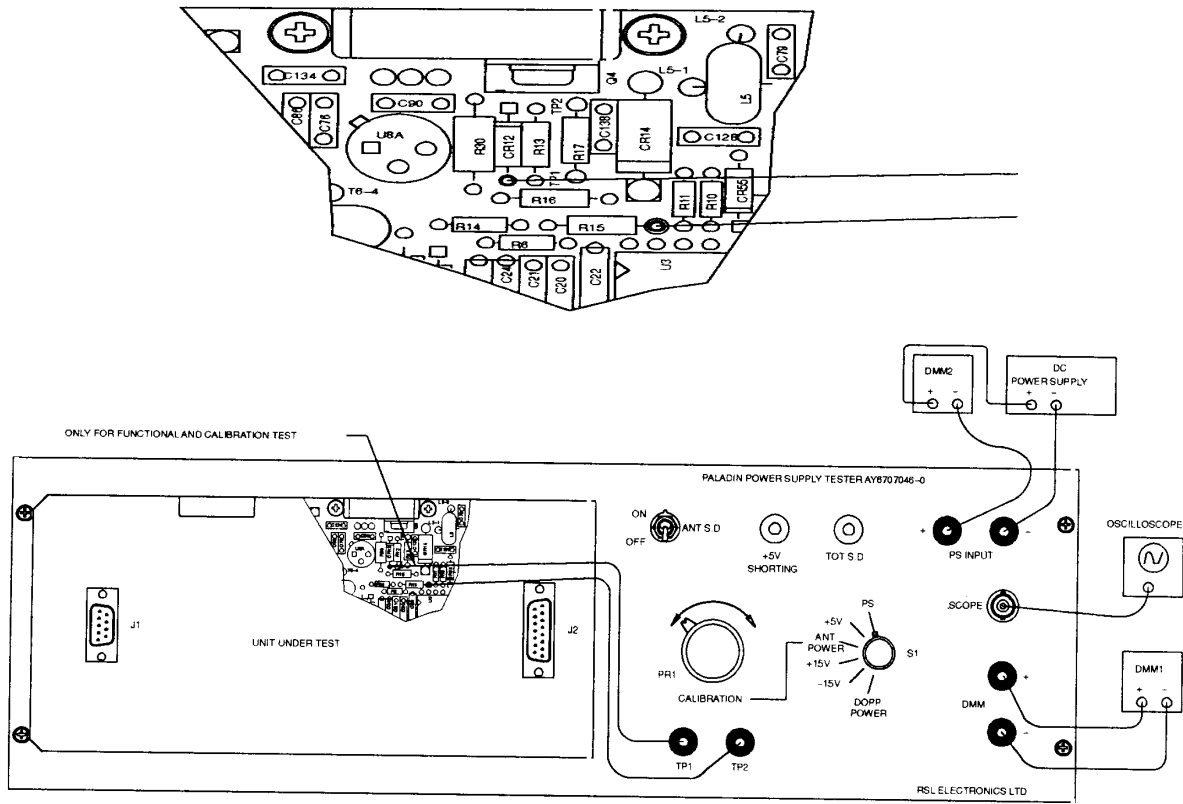

M129-18

*Figure D-29. Power Supply Module Adjustment Setup*

D.6.11.4.2 Antenna Output Adjustment Procedure. The purpose of this adjustment is to calibrate the antenna power output voltage to the operating power of the specific transceiver P/N AY6706557-0. This test is performed whenever the power supply module is combined with the transceiver and/or after replacing the transceiver itself.

- a. Connect points TP1 and TP2 in the test equipment to R15 and anode of CR12 in the tested unit (see Figure D-29.).
- b. Energize all test equipment.
- c. Set switch S1 to position ANT POWER.
- d. Record in the adjustment test data sheet, the desired voltage of the transceiver and its serial no.
- e. Turn on ANT S.D. switch.
- f. Verify voltage measure on DMM1 is  $10 \pm 1$  Vdc.
- g. Calibrate voltage measurement in DMM1 using PR1 in test equipment until the DMM1 shows the desired voltage for the transceiver is  $V \pm 0.1$  Vdc.

- H. Turn off ANT S.D. switch.
- D.6.11.4.3 Selection of Resistors.
- Deenergize all test equipment.
  - Disconnect clips TP1 and TP2 from the tested unit.
  - Measure with the DMM the resistance between TP1 and TP2 in the test equipment and record in the adjustment data sheet RM.
  - Choose resistors combination type RLRO5 or RNC5O at least 2% accuracy with the nearest resistance to the resistance RM. See Table D-13. and record in the data sheet Table D-14.
  - Using soldering iron, solder the chosen resistors R16 & R17 in the UUT.

Table D-13. Resistors Selection List

R17	R16	
14KΩ	499Ω	732Ω
15KΩ	511Ω	750Ω
15.4KΩ	523Ω	768Ω
15.8KΩ	536Ω	787Ω
16.2KΩ	549Ω	806Ω
16.5KΩ	562Ω	825Ω
16.9KΩ	576Ω	845Ω
17.4KΩ	590Ω	866Ω
17.8KΩ	604Ω	887Ω
18.2KΩ	614Ω	909Ω
18.7KΩ	634Ω	931Ω
19.1KΩ	649Ω	953Ω
19.6KΩ	665Ω	976Ω
20KΩ	681Ω	1000Ω
20.5KΩ	698Ω	
21KΩ	715Ω	
21.5KΩ		
22.1KΩ		
22.6KΩ		
23.2KΩ		

- D.6.11.4.4 Adjustment Test.
- Energize all test equipment.
  - Turn on ANT S.D. switch.
  - Verify voltage measure in DMM1:  
 $V_{out} = V \pm 0.1V_{dc}$   
 (Where V is the desired voltage to the transceiver.)
  - Turn off ANT S.D. switch.

**ARMY TM 9-1290-365-24&P**

D.6.1 1.4.5 Deenergize all test equipment.

End of test

*Table D-14. Power Supply Module Adjustment Data Sheet*

SER NO.

D.6.11.4.2d. SERIAL NO. RF MODULE  
DESIRED VOLTAGE V= \_\_\_\_\_  
D.6.11.4.2e. OUTPUT VOLTAGE I 0+10 Vdc \_\_\_\_\_  
D.6.11.4.3c. MEASURED RESISTANCE RM \_\_\_\_\_  
D.6.11.4.3d. CHOSEN RESISTORS R1 6 \_\_\_\_\_  
R1 7 \_\_\_\_\_  
D.6.11.4.4c. MEASURED Vout = \_\_\_\_\_  
Date: \_\_\_\_\_  
Tested by: \_\_\_\_\_  
Inspected by: \_\_\_\_\_

**D.6.1 2 Troubleshooting.** This paragraph contains the troubleshooting procedures for UUT failures detected during testing. It is arranged in the sequence of test steps, and provides information on additional test steps required for the malfunction isolation. Refer to FO-4 for schematic diagram. Refer to D-25 for components location.



**CAUTION**

**The power supply module contains components subject to damage by electrostatic discharge. Use approved grounding procedures before touching, removing, or inserting CCA.**

**CAUTION**

**Deenergize all external power supplies and other test equipment when disassembling or reassembling the UUT.**

**NOTE**

In all troubleshooting procedures, when additional disassembly or reassembly is required, refer to the appropriate disassembly (D.6.5) or reassembly (D.6.10) procedure.

After completion of troubleshooting and repair, perform the complete test procedure from the start.

In all troubleshooting procedures the test equipment and voltage settings shall be IAW the test procedure.

Voltages shall be measured to their respective grounds.

D.6.12.1 +5V OUTPUT FAILURE. Failure in test procedure para. D.6.11.3.1.

- a. Check other output voltages. If exists, Check transformer T9.
- b. Check for short circuit on output. If shortened, check L4, T9, and related components.
- c. Proceed with troubleshooting IAW para. D.6.12.10.

D.6.12.2 ANTENNA POWER OUTPUT FAILURE. Failure in test procedure para. D.6.11.3.2.

- a. Check the ON/OFF control circuit Q9 and its related components at both positions of ANT.SD switch on the test fixture. At OFF, Q9 should not conduct any current. At ON, Q9 should be saturated.
- b. Check main transformers T3 and T4 output pins 5 and 4 for  $270 \pm 30\text{KHz}$ ,  $105 \pm 2\text{V}$  positive amplitude of the wave form. Check diodes CR7, CR8. Check transformer T6, and related components.
- c. Set ANT.SD switch to OFF. Check U3, pin 1 is less then 0.5V. Check CR10 conduct. Check Q4 is cutoff.
- d. Set ANT.SD switch to ON. Check Q4/Gate, is 0.1 to 0.5V. Disregard spikes below 1 .5V peak. Check CR10 cutoff. Check Q4 is conducting.
- e. Check output filter circuit T7 and related components.

D.6.12.3 +15V OUTPUT FAILURE. Failure in test procedure para. D.6.11.3.3.

- a. Check main transformers T3 and T4 output pins 6 and 7 for  $270 \pm 30\text{KHz}$ ,  $20 \pm 1\text{V}$  upper side amplitude. Check diodes CR24, CR25.
- b. Check the voltage regulator circuit U4 and its related components.
- c. Check output filter circuit T8 and related components.

D.6.12.4 -15V OUTPUT FAILURE. Failure in test procedure para. D.6.11.3.4.

- a. Check  $-20 \pm 1\text{Vdc}$  on U5 pin 2. Check T3 and T4. Check diodes CR29, CR30.
- b. Check the voltage regulator circuit U5 and its related components.
- c. Check output filter circuit T8 and related components.

D.6.12.5 DOPPLER POWER OUTPUT FAILURE. Failure in test procedure para. D.6.11.3.5.

- a. Check main transformers T3 and T4 output pins 13 and 14 for  $270 \pm 30\text{KHz}$ ,  $25 \pm 2\text{V}$  upper side amplitude. Check diodes CR44, CR45.
- b. Check the voltage regulator circuit U8 and its related components.
- c. Check output filter circuit T10 and related components.

D.6.12.6 SHUTDOWN FAILURE.

D.6.12.6.1 Failure in test procedure para. D.6.11.3.6.

- a. Verify 2.5 Vdc on U10 /Cathode.
- b. Press TOT.SD switch. Check less then 2V on U1, pin 6. If failed, check CR56, R65.
- c. Check above 14V on U1, pin 7. If failed, replace U1 .
- d. Check CR39 conducting capabilities.
- e. If good, replace U2.

D.6.12.6.2 Failure in test procedure para. D.6.11.3.6b.

- a. Press TOT.SD switch. Check less then 2V on U1, pin 6. If failed, check CR37.
- b. Check below 1 V on U1, pin 1 If failed, replace U1 .
- c. Check CR18 conduct.
- d. If good, replace Q2.

## ARMY TM 9-1290-365-24&P

D.6.12.7 REVERSE POLARITY FAILURE. Failure in test procedure para. D.6.11.3.7. Check CR1. Replace if failed.

D.6.12.8 OPERATING RANGE FAILURE. Failure in test procedure para. D.6.11.3.8.

- a. Adjust input voltage to 13Vdc. Check diodes CR15, CR47.
- b. Check U1, pin 1 for more than +10V. If failed, replace U1 .
- c. Check diode CR18.
- d. Adjust input voltage to 17Vdc. Check U1, pin 1 for less than 0.5V.

D.6.12.9 SHORT CIRCUIT PROTECTION FAILURE. Failure in test procedure para. D.6.11.3.9.

- a. Press +5V SHORTING button, and verify voltage on R20 increases. If failed, replace T5.
- b. Check diodes CR20, CR21, CR22.
- c. Check Q10 is saturated when +5V SHORTING button is pressed. Replace Q10 if failed.
- d. Check diodes CR53, CR54.

D.6.12.10 NO OPERATION FAILURES.

- a. Check input filter circuit CR10, T1, T2, CR2, CR51 and related components.
- b. Check U2, pin 7 for minimum 14Vdc. If failed, check startup circuit IAW para. D.6.1 2.11 .
- c. Check U2, pin 6 for  $270 \pm 30$ KHz oscillations. If failed, check Q10 is not shortened. Verify 2.5Vdc on U10 /cathode. Replace U10 if failed. Check less than 0.5V on U1, pin 7. Check diode CR39. Else, replace U2.
- d. Check Q1 /source for  $28 \pm 1$ Vdc. If failed, check  $36 \pm 1$ Vdc on Q1 /Gate. Check CR3, CR4, CR5. Else, replace Q1 .
- e. Check  $28 \pm 1$  Vdc on T5, pin 2. If failed, check L1 and T5.
- f. Check T3 & T4, pins 1 & 2 are not shortened or disconnected.
- g. Check on Q3/gate for  $270 \pm 30$ KHz oscillations. If failed, check CR19, R1 9.
- h. Check on Q3/drain for  $270 \pm 30$ KHz oscillations. If failed, replace Q3.
- i. Check T4, pins 1 & 2 for  $270 \pm 30$ KHz,  $23 \pm 1$ V upper side amplitude. Check CR23.
- j. Check T5, pins 3 & 4 for  $270 \pm 30$ KHz, with amplitude below 3V. Disregard spikes. Check diodes CR20, CR21, CR22.
- k. Verify 2.5Vdc on U9/cathode. Check U6, pin-1 for  $4 \pm 0.5$ Vdc. Disregard spikes. Check optocoupler OC2 conducts.

D.6.12.11 STARTUP CIRCUIT FAILURES.

- a. Check that CR56 is not shortened.
- b. Check diodes CR15, CR47.
- c. Check U1, pin 1 for more than 12Vdc. If failed, replace U1 .
- d. Check CR18.
- e. Check Q2/gate for  $16 \pm 1$ Vdc. If failed check R22, CR49.
- f. Check that Q2 conducts. If failed, replace Q2.
- g. Check CR16.

D.6.13 Final Testing.

D.6.13.1 FINAL TESTING PROCEDURES. The final testing is performed on a reassembled UUT The test setup provided in Figure D-26. shows the equipment used and cable hookup for the first procedural step.



**ARMY TM 9-1290-365-24&P**

D.6.1 3.2 TEST DATA SHEETS. The test data sheets in Table D-12., are to be reproduced locally, as required, for recording the test results. The test data sheets must be completed each time a test section is performed. The completed test data sheets shall be retained.

D.6.13.3 PREPARATION FOR TEST.

- a. Reassemble the UUT IAW para. D.6.10.3.
- b. Energize and adjust DMM1 to measure DC volts.
- c. Energize and adjust DMM2 to measure high DC current (10 Amp).
- d. Set switch S1 on the test fixture to PS position.
- e. Set ANT S.D switch on the test fixture to OFF position.
- f. Energize and adjust DC power supply to measure  $+28 \pm 1$  Vdc. Deenergize DC power supply.
- g. Before connecting the UUT to the test setup, verify that the DC power supply is deenergized.
- h. Connect the UUT to the test setup IAW Figure D-26.

D.6.13.4 FINAL TESTING. Perform the final testing IAW para.D.6.11.3.



**SECTION VII. MUZZLE VELOCITY PROCESSOR (MVP)  
CIRCUIT CARD ASSEMBLY (CCA), P/N's AY6707288-3,  
AY6707288-4, and AY6701 0314**

**SECTION CONTENTS**

<b>Subject</b>	<b>Page</b>
General.....	D-81
Test Equipment and Special Tools Required.....	D-81
Materials Required.....	D-82
General Repair Requirements.....	D-83
MVP CCA Configurations.....	D-83
MVP CCA Disassembly.....	D-84
Cleaning.....	D-84
Visual Inspection.....	D-84
Repair.....	D-84
Painting.....	D-84
MVP CCA Reassembly.....	D-90
Testing.....	D-90
Troubleshooting.....	D-98
Preprogrammed Components Programming Procedure.....	D-103
Final Testing.....	D-104

---

**D.7 MUZZLE VELOCITY PROCESSOR (MVP) CIRCUIT CARD ASSEMBLY (CCA), PIN'S  
AY6707288-3, AY6707288-4, AND AY67010314**

**D.7.1 General.** This section provides repair procedures and maintenance information for the MVP CCA, P/N's AY6707288-3, AY6707288-4, and AY6701 0314. Source, maintenance and recoverability code is PADDD.

**D.7.2 Test Equipment and Special Tools Required.** Test equipment and special tools requirements are listed in Table D-15. Unless otherwise specified, the test equipment and special tools listed below will be used for testing the MVP CCA. Each commercially available item of test equipment can be replaced by equipment equivalent to that listed.

**ARMY TM 9-1290-365-24&P**

*Table D-15. Test Equipment and Special Tools Required*

<b>Nomenclature</b>	<b>Part/Spec. No.</b>	<b>Figure</b>
Coaxial Cables, BNC, Male—To—Male, 50 ohm, (4)	Local Manufacture	N/A
Digital Counter	Fluke, Model 7250A	C-11, 32
Digital Multimeter	Hewlett Packard, Model 3478A	C-11, 33
Electronic Equipment Tool Kit	PPL863	C-11, 11
Function Generator	Wavetek, Model 178	C-11, 16
Oscilloscope	Hewlett Packard, Model 10708	C-11, 17
Test Set, Paladin MVP	RSL, P/N AY6708004-0	C-11, 45
BUS-1553 Simulator	RSL, P/N AY67081 16—0	C-11, 37
BUS-1553 Simulation Cable	RSL, P/N WA6708170-0	C-11, 39
Serial Communication Cable	RSL, P/N WA67081 67-0	C-11, 38
Personal Computer	IBM 386 PC or compatible	C-11, 19
M93 1553 Test Software Diskette	RSL, P/N RD67081 81-0	C-11, 20
ESD Work Station Kit	M87893-02	C-11, 13

**D.7.3 Materials Required.** Repair materials and other consumable items required are listed in Table D-16

*Table D-16. Materials Required*

<b>Nomenclature</b>	<b>Part/Spec. No.</b>	<b>Appendix F Item No.</b>
Adhesive	MIL-A-46146, Type III	19
Epoxy Glue	MMM-A-134	34
Insulation Compound	MIL-I-46058 TYPE 1B31	9
Solder	SN63WRMAP3	23
Lubricant Tape	Tape 75 (3M)	35
Sealing Compound	83-31	16
Primer	747-55	17
Insulation Tubing	M221 29-22-N	25
Bus Wire	QQ-W-343/S-22-S1T	13
Label	DAT-59-652-1 (Brady)	36
Label	DAT-50-652-1 (Brady)	37
Antistatic Bag	3271576	31

**D.7.4 General Repair Requirements.** Refer to Figures D-30, D-31, and D-32. The following general requirements apply to the repair of MVP CCA.



**CAUTION**

**The MVP CCA contains components subject to damage by electrostatic discharge (ESD). Use approved grounding procedures before touching, removing, or inserting CCA.**

- a. Ensure that components are properly oriented before installing.
- b. Square mounting pad designates:
  - (1) Pin 1 of integrated circuit
  - (2) Emitter of transistor
  - (3) Cathode of diode
  - (4) Positive lead of capacitor
- c. Do not bend leads of component U34.
- d. Bond components C38, C39, C42, and C44 to printed wiring board (PWB) with MIL-A-46146, Type III adhesive before applying insulation compound.
- e. Use only SN63WRMAP3 tin/lead solder or approved equivalent.

**CAUTION**

**Insulation compound must not be applied to any connector pins. Inadvertent application of compound to connector pins may require replacement of connector.**

- f. Apply uniform coating of MIL-I-46058 TYPE 1B31 insulation compound 0.003±0.002 in. thick, where compound has been removed during CCA repairs.
- g. Do not apply insulation compound to mounting holes on either side of PWB, and to test points TP1 through TP5.
- h. Apply primer MIL-S-22473 grade T and sealing compound MIL-S-22473 grade CV to threads.
- i. Bond acceleration switch AC1 to holder using MMM-A-134 epoxy glue.

**D.7.5 MVP CCA Configurations.**

**D.7.5.1 CONFIGURATIONS.** The MVP CCA exists in three operational configurations. Table D-17 provides the a cross reference to respective M93 MVS transceiver assembly configuration and MVP electrical schematic diagram.

*Table D-17 MVP CCA Configurations*

<b>MVP CCA</b>	<b>M93 MVS TRANSCEIVER ASSEMBLY</b>	<b>MVP ELECTRICAL SCHEMATIC DIAGRAM</b>
AY6707288-3	AY6707292-3	L06706551-0
AY6707288-4	AY6707292-4	LD6706551-1
AY67010314	AY6707292-5	LD67010201

## **ARMY TM 9-1290-365-24&P**

0.7.5.2 CONFIGURATIONS DESCRIPTION. The M93 MVS transceiver assembly has three basic configurations. The AY6707292-5 configuration includes an internal Doppler simulation circuit that allows automatic self test of the microwave section. The AY6707292-3 configuration does not include the internal Doppler simulation circuit. The AY6707292-4 configuration is an intermediate version, which includes the Doppler simulation circuit on a modified MVP CCA AY6707288-4.

### 0.7.5.3 INTERCHANGEABILITY

- a. MVP CCA P/N AY6707288-3 can be installed only into MVS transceiver assembly P/N AY6707292-3.
- b. MVP CCAs P/N AY6707288-4 and AY6701 0314 are interchangeable and can be installed into any configuration of the MVS transceiver assembly without affecting fit, form, or function. The MVP CCA automatically detects the existence of the internal simulation assembly, and operates accordingly.

## **D.7.6 MVP CCA Disassembly.**

D.7.6.1 REMOVAL. If necessary, remove MVP CCA IAW para. D.4.6.8.

D.7.6.2 DSP DISASSEMBLY. Refer to Figure D-30.

- a. Remove four screws (8), four lock washers (9), eight flat washers (10), and four nuts (11).
- b. Remove housing (6) and thermal sheet (5).
- c. Carefully extract DSP (4) from the socket (7).
- d. Place DSP onto an antistatic foam and place it in an antistatic bag.

**D.7.7 Cleaning.** Refer to para. 3.1.3 in Chapter 3 of this manual.

**D.7.8 Visual Inspection.** Refer to Figures D-30, D-31, and D-32.

- a. Inspect connectors for damaged pins and foreign matter.
- b. Inspect all components for security of attachment.
- c. Inspect all parts for damage, wear, and deterioration.
- d. Inspect all parts for nicks, scoring, dents, scratches, and broken runs.
- e. Inspect all electronic components for indication of overheating, cracked bodies, loose terminals, broken leads, cold solder joints, and other indications of damage or deterioration.

**D.7.9 Repair.** Repair defective parts that were noticed during preshop analysis (para. D.3) and visual inspection (para. D.7.8).

**D.7.10 Painting.** No painting required on MVP CCA.

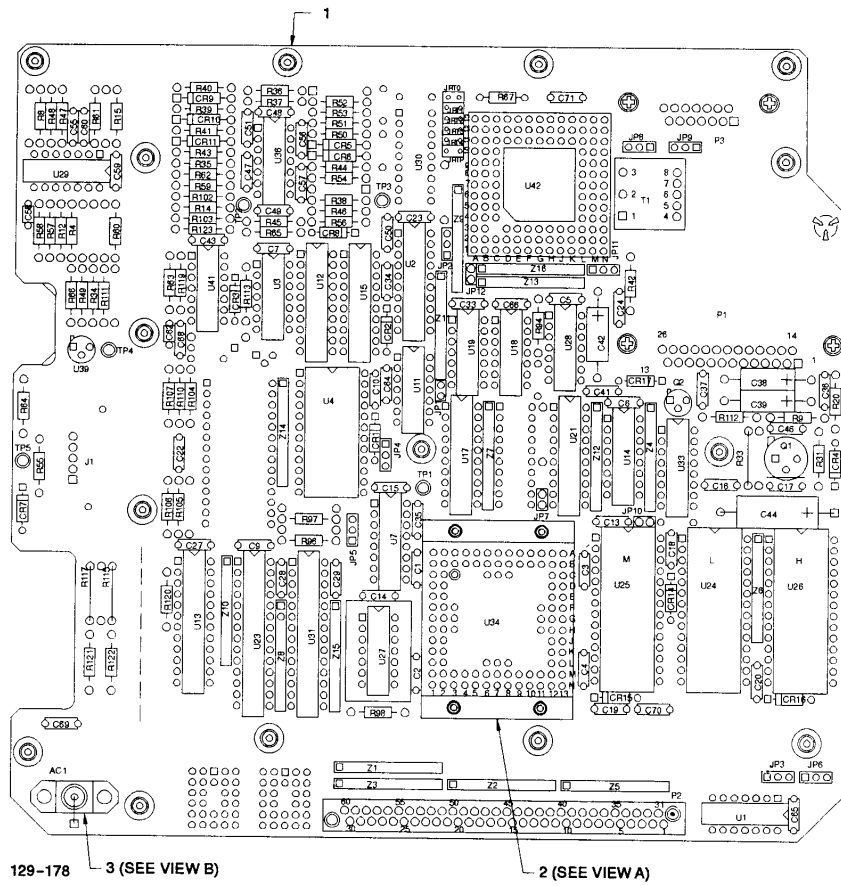
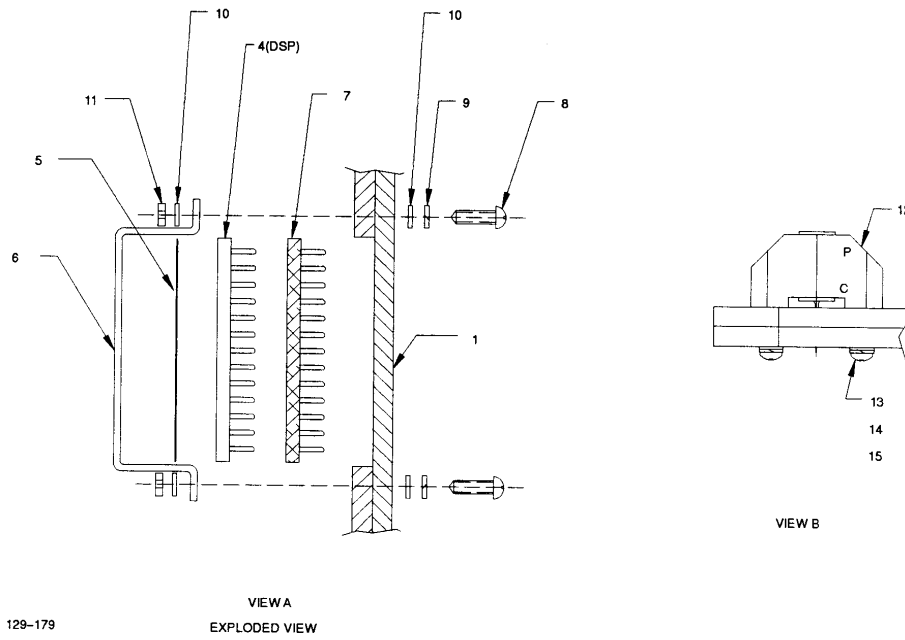

Figure D-30. MVP CCA, AY6707288-3 (Sheet 1 of 2)



DSP and Acceleration Switch Assembly

Figure D-30. MVP CCA, AY6707288-3 (Sheet 2 of 2)



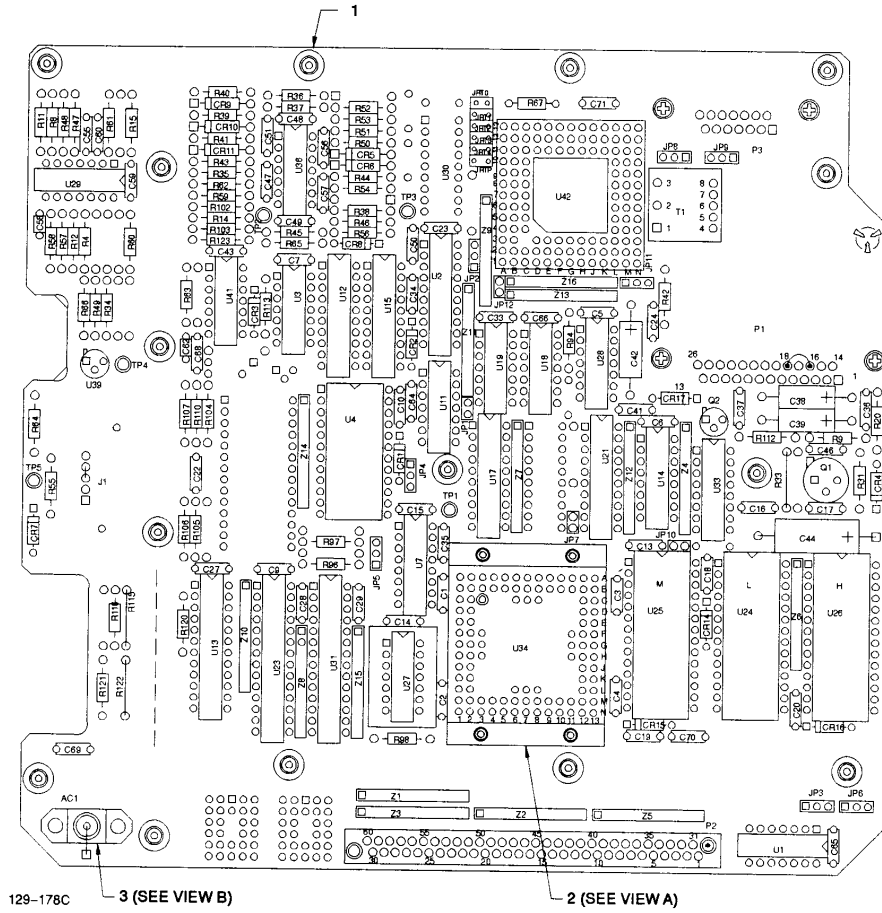

Component Side

Figure D-31. MVP CCA, AY6707288-4 (Sheet 1 of 2)

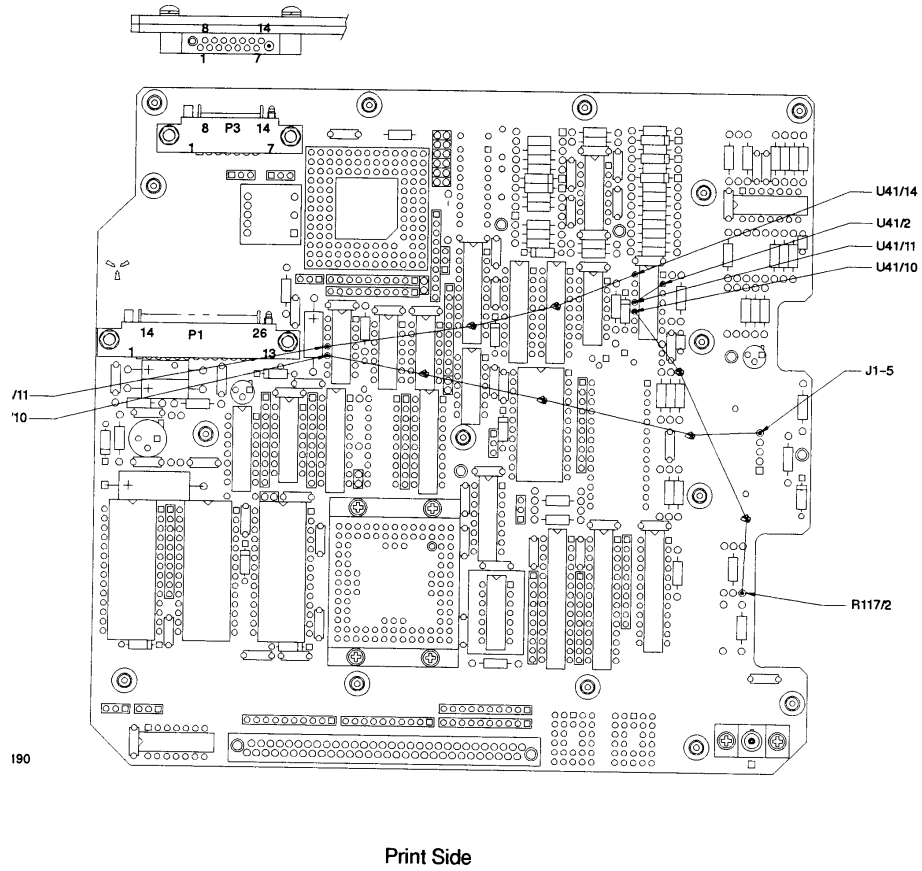

Figure D-31. MVP CCA, AY6707288-4 (Sheet 2 of 2)

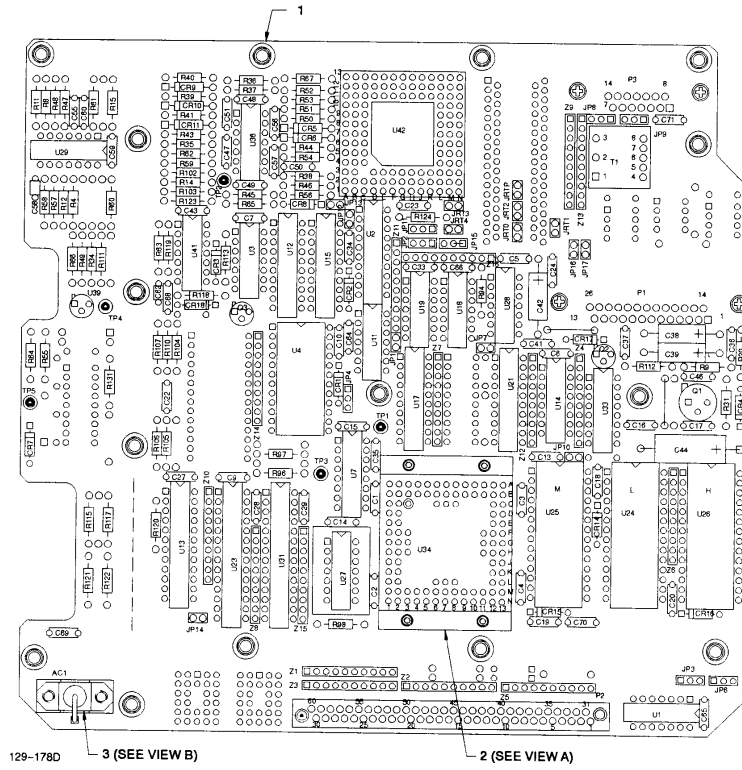

Figure D-32. MVP CCA, AY67010314

## ARMY TM 9-1290-365-24&P

D.7.11 MVP CCA Reassembly.

D.7.11.1 ACCELERATION SWITCH REASSEMBLY. DELETED

D.7.11.2 DSP REASSEMBLY. Refer to Figure D-30.

- a. Carefully insert DSP (4) to the socket (7). Pay attention to the correct orientation of the component.
- b. Install housing (6) and thermal sheet (5). Use number of thermal sheets (5) as required to eliminate any space between the DSP (3) and the housing (6).
- c. Install and fasten four screws (8), four lock washers (9), eight flat washers (10), and four nuts(11).

D.7.11.3 REPLACEMENT OF PREPROGRAMMED COMPONENTS. Refer to Figure C-7. For replacement of faulty programmed EPROMs U24, U25, U26, and PAL U13, refer to para. D.7.14 for programming procedures.

0.7.11.4 INSTALLATION. Install MVP CCA IAW para. D.4.11.2.

### D.7.1 2 Testing.



CAUTION

**The MVP CCA contains components subject to damage by electrostatic discharge. Use approved grounding procedures before touching, removing, or inserting CCA.**

#### NOTE

Hereafter, the MVP CCA will be referred to as the Unit Under Test (UUT).

D.7.12.1 GENERAL

D.7.12.1.1 MVP CCA Test Procedures. The test setup provided in Figure D-33., shows the equipment used and cable hookup for the test procedure. Figures D-34. and D-35. are detailed illustrations of the special testers.

D.7.12.1.2 Test Data Sheets. The test data sheets in Table D-18. are to be reproduced locally, as required, for recording the test results. The test data sheets must be completed each time a test section is performed. The completed test data sheets shall be retained and used as a troubleshooting aid.

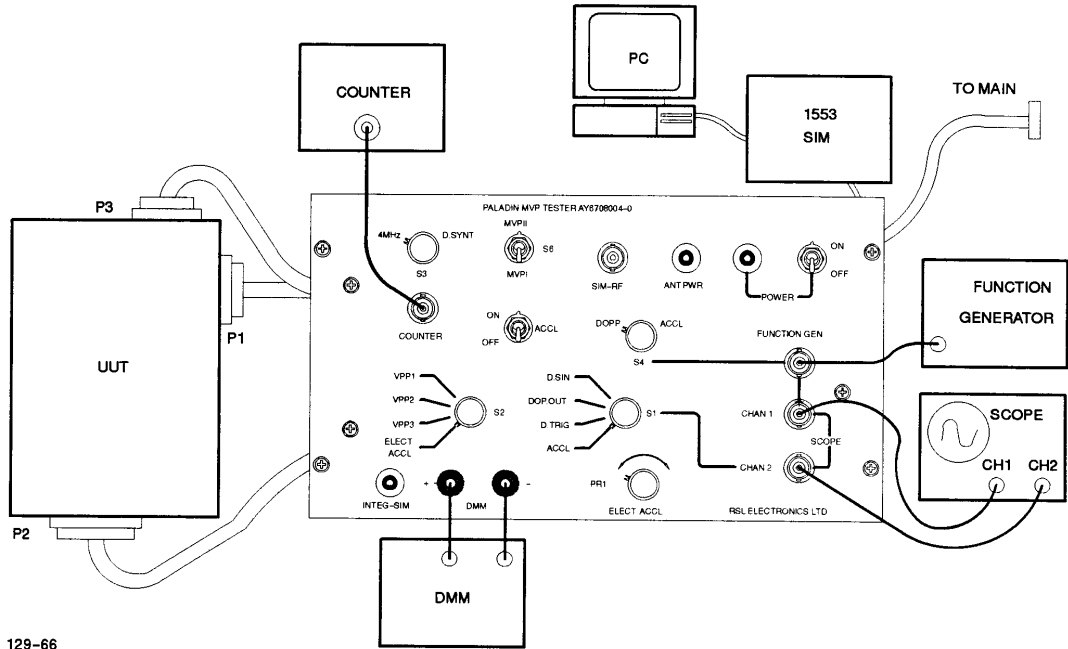

129-66

Figure D-33. MVP CCA Test Setup

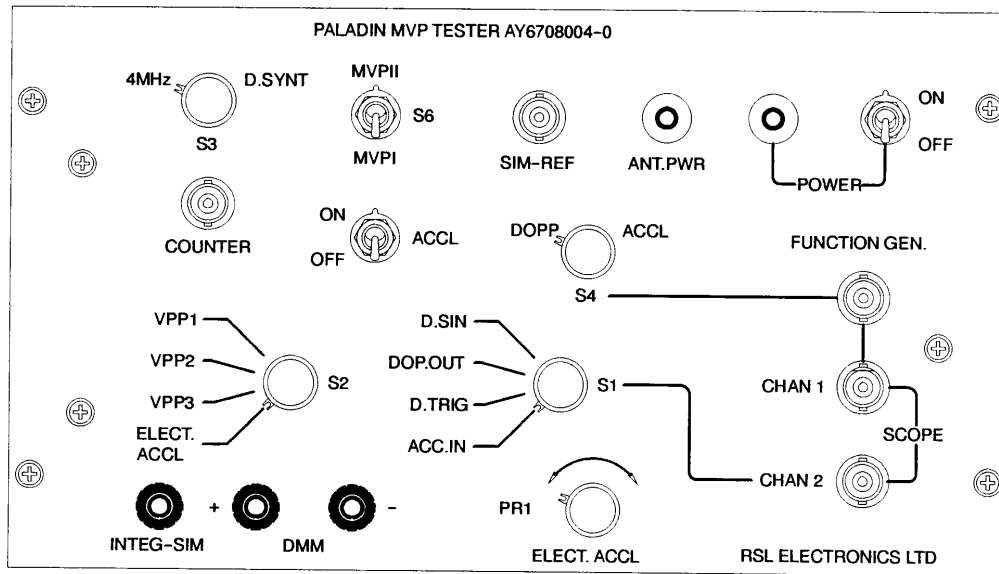

P8003

Figure D-34. MVP CCA Test Fixture

ARMY TM 9-1290-365-24&P

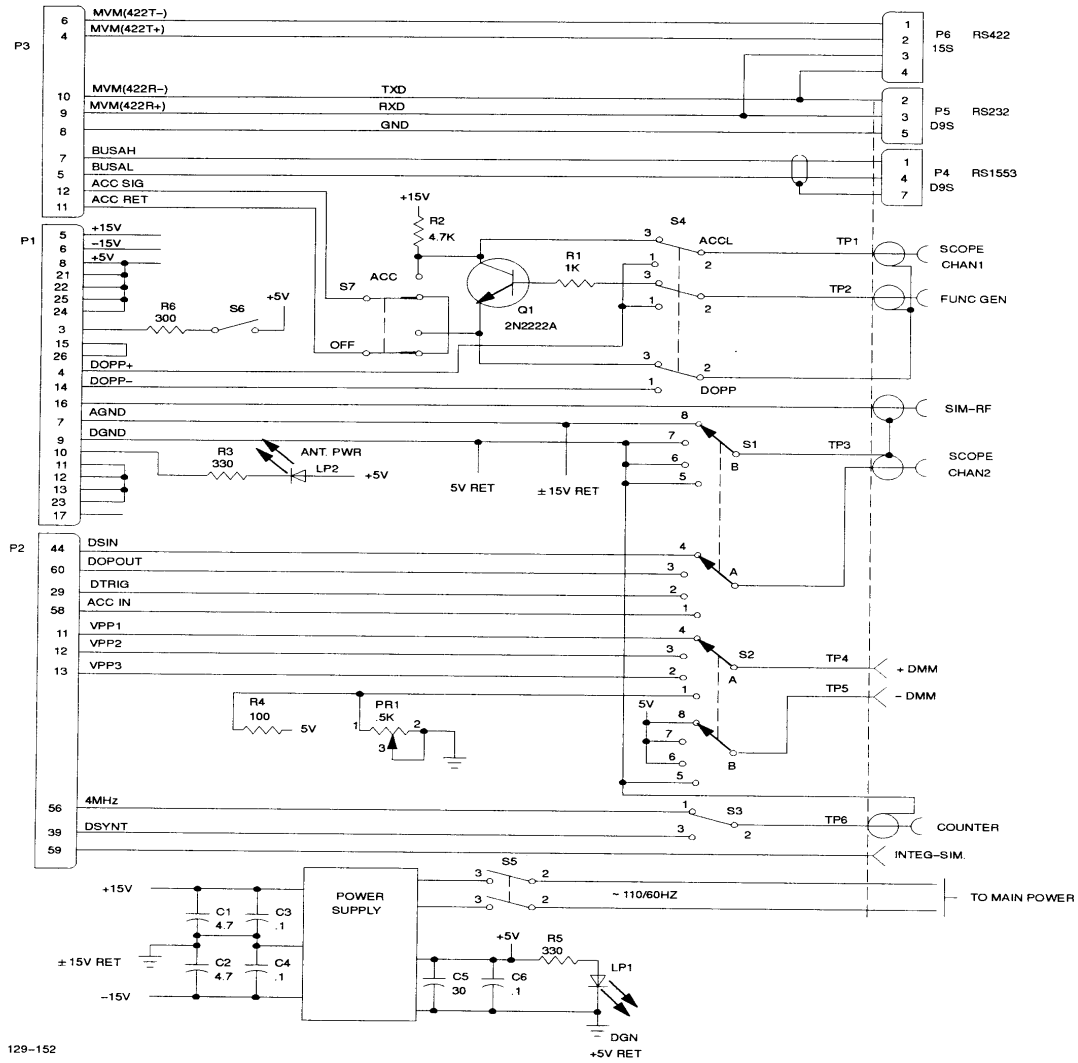

129-152

Figure D-35. MVP CCA Test Fixture Schematic

Figure D-35. MVP CCA Test Fixture Schematic

D.7.12.2 PREPARATION FOR TEST. The test is conducted on a disassembled UUT. The test setup is shown in Figure D-33. Figures D-34. and D-35. are detailed illustrations of the special testers.

- a. Remove the UUT from higher assembly IAW para. D.4.6.8.
- b. Energize and adjust digital multimeter (DMM) to measure DC volts.
- c. Set ACCL switch on the test fixture to OFF position.
- d. Set switch 51 on the test fixture to DOP.OUT position.
- e. Set switch S6 on the test fixture to MVP-II position.
- f. Set switch S3 on the test fixture to 4MHZ position.
- g. Set switch S4 on the test fixture to DOPP position.
- h. Before connecting the UUT to the test setup, verify that the test fixture is deenergized.
- i. Connect the UUT to the test setup IAW Figure D-33.

D.7.12.3 SYNTHETIC DOPPLER TEST. Refer to para. D.7.13.1 for troubleshooting procedures.

- a. Turn on the test equipment. (The power switch is located on the test equipment front panel).
- b. Verify frequency on counter is 4MHz  $\pm$ 100Hz.
- c. For version AY6707288-3, set switch S3 to position D.SYNT. Verify frequency on counter is 28 $\pm$ 2KHz.
- d. For version AY6707288-4,
  - (1) Set switch S3 to position D.SYNT. Verify frequency on counter is 28  $\pm$  2KHz.
  - (2) Connect counter to COUNTER on the test fixture. Verify frequency on counter is 28 $\pm$ 2KHz.
- e. For version AY67010314,
  - (1) Turn off the test fixture and wait for 5 seconds. Set switch S3 to position D.SYNT. Turn on the test fixture. Verify frequency on counter is 28 $\pm$  2KHz for approximately 4 seconds.
  - (2) Connect counter to COUNTER on the test fixture. Turn off the test fixture and wait for 5 seconds.
  - (3) Turn on the test fixture. Verify frequency on counter is 28  $\pm$  2KHz for approximately 4 seconds.
- f. Set switch S2 to position Vpp1 . Verify voltage measure on DMM is  $-0.3 \pm 0.3$  Vdc.
- g. Set switch S2 to position Vpp2. Verify voltage measure on DMM is  $-0.3 \pm 0.3$  Vdc.
- h. Set switch S2 to position Vpp3. Verify voltage measure on DMM is  $-0.3 \pm 0.3$  Vdc.
- i. For versions AY6707288-4 and AY67010314:
  - (1) Set switch S2 to position ELECT. ACCL.
  - (2) Connect DMM(+) to INTEG-SIM. Verify voltage measured on DMM is 0  $\pm$  0.5Vdc.
- j. For versions AY6707288—1 and AY67010314, set switch S6 to position MVP-I. Verify voltage measured on DMM is 5 $\pm$ 0.5Vdc.

D.7.12.4 ACCELERATION SWITCH TEST. DELETED

**ARMY TM 9-1290-365-24&P**

- e. Turn on ACCL. switch.
- f. Verify voltage measure on oscilloscope CHAN 2 DC mode is  $5 \pm 0.5$  Vdc.
- g. Turn on function generator and set to square wave  $5 \pm 0.3$  Vp-p,  $2.6 \pm 0.2$ Vdc offset, and  $1 \pm 0.1$ KHz.
- h. Measure the two signals on oscilloscope CHAN 1 and CHAN 2 and compare the signals. See Figure D-36. Verify delay time between channels is  $77 \pm 17$ sec.

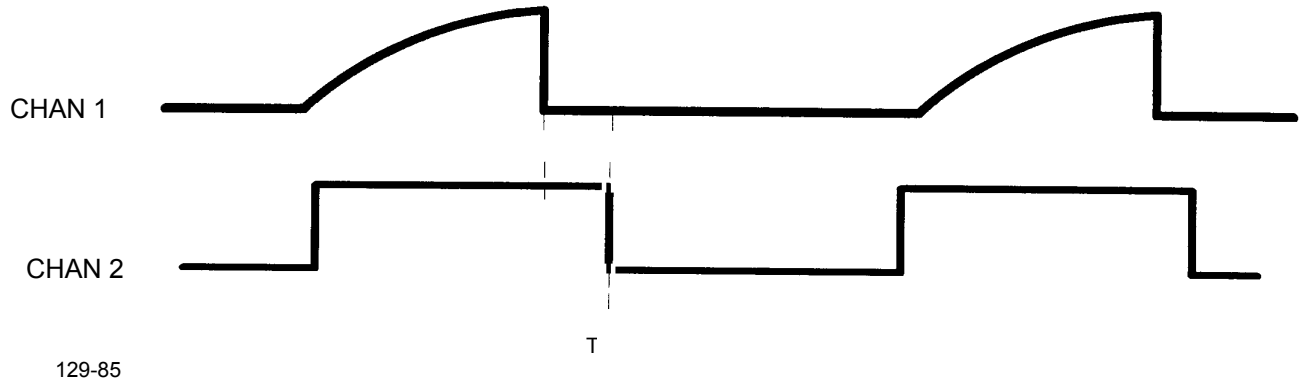

*Figure D-36. Signal Shape on Oscilloscope*

D.7.1 2.5 DOPPLER INPUT CIRCUIT TEST. Refer to para. D.7.13.3 for troubleshooting procedures.

- a. Set switch S1 to position D.SIN.
- b. Set switch S4 to position DOPP.
- c. Set the function generator to sine wave amplitude to  $400 \pm 10$  mVp-p, at frequency  $10 \pm 0.5$  KHz.
- d. Measure the signal on oscilloscope CHAN 2. Verify the signal is  $400 \pm 10$  mVp-p.
- e. Set switch S1 to position DOP. OUT.
- f. Measure the signal on oscilloscope CHAN2. Verify the signal is square wave:
  - High level  $5 \pm 0.5$  Vdc
  - Low level  $-1 \pm 0.3$  Vdc
  - Frequency  $10 \pm 0.5$  K Hz 1 100ü.sec
- g. Set switch S1 to position D.TRIG.
- h. Measure the signal on oscilloscope CHAN 2. Verify there is  $-1 \pm 0.5$  Vdc.
- i. Set the function generator to  $40 \pm 0.5$  KHz and amplitude  $8 \pm 0.5$  Vp-p.
- j. Measure the signal on oscilloscope CHAN 2. Verify pulses:
  - High level  $4.5 \pm 0.5$  Vdc
  - Low level  $-1 \pm 0.5$  Vdc



D.7.12.6 FUNCTIONAL TEST. Refer to para. D.7.13.4 for troubleshooting procedures.

- a. Turn on PC.
- b. Load software SPC1553.EXE.
- c. Set ACCL switch to OFF
- d. Set switch S6 to position MVP-II.
- e. Set switch S4 to position DOPP.

**NOTE**

During the test, the message "AAAA Stay Alive" may appear several times. (AAAA is a sequence no.) This is normal operation.

- f. Turn on the 1553 simulator.
- g. Using the mouse or keyboard on the PC choose "Start" from the EVENT menu. Verify the following message on screen:  
 "AAAA BIT FAILURE FALSE YYY.Y Ver X.X"  
 "AAAA Stay alive"  
 where:           AAAA = message sequence no.  
                   YYY.Y = 395±5m/sec.  
                   X.X = last version no.
- h. Choose "BIT Status" from the EVENT menu. Verify the following message on screen:  
 "AAAA BIT FAILURE FALSE YYY.Y Ver X.X"  
 where            AAAA = message sequence no.  
                   YYY.Y = 395 ± 5m/sec.  
                   X.X = last version no.
- i. Set velocity range from the EVENT menu to 100m/sec minimum,1000m/sec maximum.
- j. Set the function generator to 14KHz ±1Hz and amplitude 400 ±10mVp-p.
- k. Choose "SHELL" option from the EVENT menu. Turn ACCL switch to ON and then to OFF. Verify ANT. PWR led is on for approximately 3 seconds. Verify the following message on screen:  
 "AAAA Velocity YYY.Y TRUE".  
 where:           AAAA = message sequence no.  
                   YYY.Y = 199.10 ±0.5m/sec.
- l. Set function generator to 50KHz ±1Hz.
- m. Choose "SHELL" option from the EVENT menu. Turn ACCL switch to ON and then to OFF. Verify ANT PWR led is on for approximately 3 seconds. Verify the following message on screen:  
 "AAAA VELOCITY YYY.Y TRUE"  
 where:           AAAA = message sequence no.  
                   YYY.Y = 710.9 ±0.6m/sec
- n. Choose "SHELL" option from the EVENT menu. Lightly tap with a finger on the MVP CCA, near the acceleration switch housing, to activate the switch. Verify ANT PWR led is on for approximately 3 seconds. Verify the following message on screen:  
 "AAAA VELOCITY YYY.Y TRUE"  
 where:           AAAA = message sequence no.  
                   YYY.Y = 710.9 ±0.6m/sec
- o. Choose "SHUTDOWN" option from the EVENT menu, verify the following message on screen:  
 "SHUTDOWN COMPLETE".
- p. For versions AY6707288-4 and AY67010314, turn off power switch on tester wait about 5 seconds and turn on the power switch.

**ARMY TM 9-1290-365-24&P**

- q. For versions AY6707288-4 and AY6710314, choose "START" option from the EVENT menu. Verify the following message on screen:  
"AAAA BIT FAILURE TRUE: DOPPLER.YYY.Y Ver. X.X".  
where        AAAA = message sequence no.  
              YYY.Y = 395 ±5m/sec.  
              X.X = last version no.

D.7.12.7 Deenergize power supplies and all other test equipment. Disconnect UUT from the test fixture.

END OF TEST

Table D-18. MVP OCA Test Data Sheet

MVPCCASER NO. \_\_\_\_\_

Para.	Required Result	Actual Results	Remarks
D.7.12.3b.	4MHz ±100Hz		
D.7.12.3c.d.e.	28±2kHz		
D.7.12.3f.	-0.3 ± 0.3 Vdc		
D.7.12.3g.	-0.3 ± 0.3 Vdc		
D.7.12.3h.	-0.3 ± 0.3Vdc		
D.7.12.3i.	0±0.5Vdc		
D.7.12.3j.	5 ± 0.5Vdc		
D.7.12.4d.	-1 ±0.5Vdc noise		
D.7.12.4f.	5±0.5Vdc		
D.7.12.4h.	77±1 7sec		
D.7.12.5d.	400±10mVp-p		
D.7.12.5f.	High level 5±0.5Vdc		
	Low level-1± 0.3 Vdc		
	Frequency 10 ± 0.5KHz		
D.7.12.5h.	-1 ±0.5Vdc		
D.7.12.5j.	High level 4.5±0.5Vdc		
	Low level -1 ± 0.5 Vdc		
D.7.12.6g.	“AAAA BIT FAILURE FALSE YYY.Y Ver X.X YYY.Y = 395± 5m/sec X.X = last ver. “AAAA Stay Alive”		
D.7.12.6h.	“AAAA BIT FAILURE FALSE YYY.Y Ver X.X YYY.Y = 395±5m/sec X.X = last ver.		
D.7.12.6k.	“AAAA VELOCITY YYY.Y TRUE” 199.0 ± 0.5m/sec		
D.7.12.6m.	“AAAA VELOCITY YYY.Y TRUE” 710.9 ± 0.6m/sec		
D.7.12.6n.	“AAAA VELOCITY YYY.Y TRUE” 710.9 ± 0.6m/sec		
D.7.12.6o.	“SHUTDOWN COMPLETE”		
D.7.12.6q.	“AAA BIT FAILURE TRUE: DOPPLER.YYY.Y Ver X.X” YYY.Y = 395±5m/sec X.X = last ver. “AAAA Stay Alive”		

Date: \_\_\_\_\_

Tested by: \_\_\_\_\_

Inspected by: \_\_\_\_\_

## ARMY TM 9-1290-365-24&P

**D.7.13 Troubleshooting.** This paragraph contains the troubleshooting procedures for UUT failures detected during testing. It is arranged in the sequence of test steps, and provides information on additional test steps required for the malfunction isolation. Refer to Figure FO-3 for schematic diagram. Refer to Figure D-37 for DSP pinout to schematic cross reference. Refer to Figures D-30, D-31, and D-32 for components location.



**CAUTION**

**The MVP CCA contains components subject to damage by electrostatic discharge. Use approved grounding procedures before touching, removing, or inserting CCA.**

### NOTE

In all troubleshooting procedures, when additional disassembly or reassembly is required, refer to the appropriate disassembly (D.7.6) or reassembly (D.7.11) procedure.

After completion of troubleshooting and repair, perform the complete test procedure from the start.

**D.7.13.1 SYNTHETIC DOPPLER FAILURES.** Failure in test procedure para. D.7.12.3.

**D.7.13.1.1 4MHz Failure.** Failure in test procedure para. D.7.12.3b.

- a. Check for 32MHz on oscillator U27 output. If failed, replace U27.
- b. Check for 8MHz on DSP U34, pin 97. If failed, replace U34.
- c. Check for 16MHz on U7, pin 14. If failed, replace U7.
- d. Check for 4MHz on frequency divider U7, pin 12. If failed, replace U7.

**D.7.13.1 .2 28KHz Failure.** Failure in test procedure para. D.7.12.3c., d., e.

- a. Check oscillator U41 for 28KHz on pin 1. If failed, check and replace C62, R63 or U41.
- b. Check shaper U41, pin 2 and related components.

### NOTE

On version AY6707288-4 and AY67010314 the 28KHz exists briefly, during BIT. Repeat test several times, if required.

- c. For version AY6707288-4, check U41 pin 13, U28 pin 10, and U17 pin 16.
- d. For version AY6701 0314, check U17 pin 16, and U28 pin 10. Check transistor Q3 and related components. Repeat test several times, if required.

**D.7.13.1.3 Vppl,2 or 3 Failure.** Failure in test procedure para. D.7.12.3.f.g. h. Check diodes CR14, CR15, CR16. If failed, replace.

**D.7.13.1.4 Failure in Test Procedure Para. D.7.12.3i., j.** Applicable only on versions AY6707288-4 and AY6701 0314.

- a. Check U39 for 2.5 Vdc on cathode.
- b. Check comparator U29, pin 1, and related components.

D.7.13.2 Deleted

D.7.13.3 DOPPLER INPUT CIRCUIT FAILURES. Failure in test procedure para. D.7.12.5.

D.7.13.3.1 D.SIN Failure. Failure in test procedure para. D.7.12.5d.

- a. Check the Doppler input circuit diodes CR9, CR10, CR11 and related components.
- b. Check buffers and amplifier U36 outputs for signal levels equal to input level.

D.7.13.3.2 DOP.OUT Failure. Failure in test procedure para. D.7.12.5f.

- a. Check shaper U29, pin 13 for logic levels, square wave signal with the same input frequency.
- b. Check related components.

D.7.13.3.3 D.TRIG Failure. Failures in test procedure para. D.7.12.5h., j.

- a. Check U36, pin 14. Check related components.
- b. Check shaper U29, pin 2. Check related components.

D.7.13.4 FUNCTIONAL FAILURES. Failure in test procedure para. D.7.12.6.

D.7.13.4.1 No communication. The UUT does not respond to communication from PC. Failure in test procedure para. D.7.1 2.6g.

**NOTE**

Reset PC and re-run software. Reset 1553 simulator.

- a. Check for logic 1 on U33, pin 15 (/RESET). If 0 (processor is in reset state), check for proper operation of the processor circuitry IAW para D.7.1 3.5.
- b. Using oscilloscope, check that the transmission signal from PC arrives at Ti, between pins 5 and 7.
- c. Check for logic level pulses, on U42, between pins 40 and 41. If failed, replace Ti.
- d. Check for logic 0 on U33, pin 16. If failed, replace U33.
- e. Check for logic 1 on U33, pin 10. If failed, replace U33.
- f. Check for  $4.3 \pm 0.3$  Vdc on diode CR4, cathode. If failed, check diode CR4 and capacitor C44.
- g. Check for logic 0 on U33, pin 5. If failed, replace U33.
- h. Check for  $+4.5 \pm 0.5$  Vdc on collector of transistor Q1. If failed, replace Q1.
- i. Temporary replace U34 with a new component.
- j. Run the software on PC.
- k. If the failure does not reappear, the malfunction is corrected. U34 was the failed component. If the failure reappears, reassemble the original U34 and proceed with steps below. Re-run the software as many times as needed to perform the troubleshooting.
- l. Check for logic level pulses on U13, pins 21 and 18. If failed, replace U13.
- m. Check for logic level pulses on U28, pin 8. If failed, replace U28.
- n. If not failed, replace U42.

D.7.13.4.2 BIT FAILURE TRUE Failures. Failure in test procedure para. D.7.1 2.6i.

## ARMY TM 9-1290-365-24&P

### D.7.13.4.2.1 Incorrect or No Measurement Failure.

- a. Choose "SHUTDOWN" option from the EVENT menu, verify the following message on screen "SHUTDOWN COMPLETE". Turn off power switch on tester, wait about 5 second and turn on the power switch.
- b. Temporarily replace U34 with a new component.
- c. Re-run the test as many times as needed to perform the troubleshooting.
- d. If the failure does not reappear, the malfunction is corrected. U34 was the failed component. If the failure reappears, reassemble the original U34 and proceed with steps below.
- e. Check for logic level pulses on U13, pins 19 and 15. If failed, replace U13.
- f. Check for logic level pulses on U14, pins 12, 13 and 15. If failed, replace U14.
- g. Check for logic level pulses on U19, pins 3 and 6. If failed, replace U19.

#### NOTE

Due to the short period of BIT execution, the troubleshooting might need to be performed several times to verify the existence of events. Perform shutdown procedure, reset PC and re-run software, reset 1553 simulator and re-run the test as many times as needed.

- h. Check for logic 0 on U17 pin 6. If failed, replace U17.
- i. Check for logic 1 on U11 pin 12. If failed, replace U11 .
- j. Check for logic level square wave of 28KHz on U18, pin 8. If failed, replace U18.
- k. Check for logic level square wave of 28KHz on U28, pin 2. If failed, replace U28.
- l. Check for logic 0 on U8 pin 6. If failed, replace U18.
- m. Check for logic 1 on U28, pin 6. If failed, replace U28.
- n. Check for logic level square wave of 28KHz on U18, pin 11. If failed, replace U18.
- o. Check for logic level pulses on U4, pins 10, f=333KHz, and U4/1 7, f=41.6KHz. If failed, replace U4.
- p. Check for logic level pulses on U3, pins 3, 4, 5, 6, 10, 11, 12 and 13. If failed, replace U3.
- q. Check for logic level pulses on U11, pin 2. If failed, replace U11.
- r. If not failed, replace U12.
- s. Replace EPROM's U24, U25, U26.

### D.7.1 3.4.2.2 Possible RAM Failures.

- a. Choose "SHUTDOWN" option from the EVENT menu, verify the following message on screen "SHUTDOWN COMPLETE". Turn off power switch on tester, wait about 5 seconds and turn on the power switch.
- b. Temporarily replace U34 with a new component.
- c. Re-run the test as many times as needed to perform the troubleshooting.
- d. If the failure does not reappear, the malfunction is corrected. U34 was the failed component. If the failure reappears, reassemble the original U34 and proceed with steps below.
- e. Check for  $4.3 \pm 0.3\text{Vdc}$  on diode CR4, cathode. If failed, check diode CR4 and capacitor C44.
- f. Check for logic 0 on U33, pin 5. If failed, replace U33.
- g. Check for  $+4.5+0.5\text{Vdc}$  on collector of transistor Q1. If failed, replace Q1.
- h. Repeat test. Re-run the test as many times as needed to perform the troubleshooting.

- i. Check for logic level pulses on U13, pin 19. If failed, replace U13.
- j. Check for logic level pulses on U14, pin 14. If failed, replace U14.
- k. Check for logic level pulses on U19, pin 11. If failed, replace U19.
- l. Check for logic level pulses on U15, pins 2,5 and 6. If failed, replace U15.
- m. Check for logic level pulses on U13, pins 16 and 23. If failed, replace U13.
- n. Check for logic level pulses on U21, pins 18, 5 and 3. If failed, replace U21.
- o. If not failed, replace U23 and U31.

D.7.1 3.4.2.3 Possible PORTS Failures.

- a. Choose "SHUTDOWN" option from the EVENT menu, verify the following message on screen "SHUTDOWN COMPLETE". Turn off power switch on tester, wait about 5 seconds and turn on the power switch.
- b. Temporarily replace U34 with a new component.
- c. Re-run the test as many times as needed to perform the troubleshooting.
- d. If the failure does not reappear, the malfunction is corrected. U34 was the failed component. If the failure reappears, reassemble the original U34 and proceed with steps below.
- e. Check for logic level pulses on U13, pin 19. If failed, replace U13.
- f. Check for logic level pulses on U14, pins 13 and 14. If failed, replace U14.
- g. Check for logic level pulses on U19, pins 3, 8 and 11. If failed, replace U1 9.
- h. Check for logic level pulses on U17, pin 15. If failed, replace U1 7.
- i. Check for logic level pulses on U15, pin 19. If failed, replace U15.
- j. If not failed, replace U2.

D.7.13.4.3 Measurement Failures. Failure in test procedure para. D.7.1 2.6k., m.

D.7.13.4.3.1 ANT.PWR Indicator Failure.

- a. Check for logic 0 on U17, pin 5. If failed, replace U17.
- b. Check for transistor Q2, shorted emitter or collector not shorted. If shorted, remove shorting or replace Q2.
- c. Choose "SHELL" option from the EVENT menu. Turn ACOL switch to ON and then to OFF. Re-run the test as many times as needed to perform the troubleshooting. Deenergize function generator for troubleshooting.
- d. Choose "SHELL" option from the EVENT menu and turn ACCL switch to ON, check for logic 1 on U17, pin 5. If failed, replace U17.
- e. Check for  $0.7 \pm 0.2V_{dc}$  on transistor Q2 base. If failed, check diode CR17, resistors R112 R9. Check that Q2 base is not shorted to ground.
- f. Check for transistor Q2 is saturated. If failed, replace Q2.

D.7.1 3.4.3.2 Incorrect or No Measurement Result Failure.

- a. Choose "SHELL" option from the EVENT menu. Turn ACCL switch to ON and then to OFF. Re-run the test as many times as needed to perform the troubleshooting.
- b. Check for logic 1 on U17, pin 6. If failed, replace U17.
- c. Check for logic 0 on U11 pin 12. If failed, replace U11
- d. Check for logic level square wave of 50KHz on U18, pin 6. If failed, replace U18.

- e. Check for logic level square wave of 50KHz on U28, pin 6. If failed, replace U28.
- f. Check for logic 0 on U18, pin 8. If failed, replace U18.
- g. Check for logic 1 on U28, pin 2. If failed, replace U28.
- h. Check for logic level square wave of 50KHz on U18, pin 11. If failed, replace U18.
- i. If not failed, replace U2.
- j. Replace EPROM's U24, U25, U26.

**D.7.13.4.4 Acceleration Switch Failure.** Failure in test procedure para. D.7.12.6n.

- a. Choose "SHELL" option from the EVENT menu. Re-run the test as many times as needed to perform the troubleshooting.
- b. lightly tap with finger on the acceleration switch AC1 housing. Check for +1 5Vdc pulses on diode CR3, anode. Check resistor R13.
- c. If not failed, replace acceleration switch AC1.

**D.7.13.5 PROCESSOR CIRCUITRY NO OPERATION FAILURES.**

- a. Remove U34.
- b. Check Program Memory Address (PMAO through PMA1 3, PMDA, PMRD, PMS) bus for short to ground. Refer to Figure FO-3, sheet 2 for pin number designation. Refer to Figure D-37. for DSP pinout to schematic cross reference. If a short is visibly recognizable, remove it. Check the resistor networks Z5 and Z6. If not failed, the short is caused by one of the EPROM's, U24, U25, U26. Replace one by one the EPROM's, and repeat the short test.
- c. Check Program Memory Data (PM DO through PMD23) bus for short to ground. Refer to Figure FO-3, sheet 2 for pin number designation. If a short is visibly recognizable, remove it. Check the resistor networks Z1, Z2, and Z3. If not failed, replace the component (U24, U25, or U26) that causes the short circuit.
- d. Check Data Memory Address (DMAO through DMA13, DMWR, DMRD, DMS, DMACK) bus for short to ground. Refer to Figure FO-3, sheets 2, 3 and 4 for pin number designation. If a short is visibly recognizable, remove it. Check the resistor networks Z9 and Z10. If not failed, the short is caused by one of the components on the bus, U13, U14, U42, U31, U32. Replace one by one the components, and repeat the short test.
- e. Check Data Memory Data (DMD0 through DMD15) bus for short to ground. Refer to Figure FO-3, sheets 2, 3 and 4 for pin number designation. If a short is visibly recognizable, remove it. Check the resistor networks Z7, Z8 and Z9. If not failed, the short is caused by one of the components on the bus, U15, U2, U12, U17, U31, U32, U4, U42. Replace one by one the components, and repeat the short test.
- f. Temporarily replace U34 with a new component.
- g. Repeat test again.
- h. If the failure does not reappear, the malfunction is corrected. U34 was the failed component. If the failure reappears, reassemble the original U34 and proceed with steps below. Re-run the test as many times as needed to perform the troubleshooting.
- i. Check for logic 1 on U33, pins 10 and 16. If failed, replace U33.
- j. Check for logic 0 on U33, pin 15. If failed, replace U33.
- k. Check for  $4.3 \pm -0.3\text{Vdc}$  on diode CR4, cathode. If failed, check diode CR4 and capacitor C44.
- l. Check for logic 0 on U33, pin 5. If failed, replace U33.
- m. Check for  $+4.5+0.5\text{Vdc}$  on collector of transistor Q1. If failed, replace Q1.



n. Replace one by one the following components, U13, U14, U19, U15, U17, U24, U25, U26.

	1	2	3	4	5	6	7	8	9	10	11	12	13	
N	25 DMA0	26 RESET	27 HALT	28 TRAP	29 PMS	30 GND	31 GND	32 VDD	33 BG	34 DMD23	35 PMD21	36 PMD20	37 PMD18	
M	24 DMA2	69 GND	70 DMACK	71 PMDA	72 DMS	73 DMWR	74 DMRD	75 BR	76 PMRD	77 PMD22	78 PMD19	79 PMD17	38 PMD16	
L	23 DMA3	68 DMA1				95 PMWR	96 CLKI	97 CLKO				80 PMD15	39 PMD14	
K	22 DMA5	67 DMA4										81 PMD13	40 PMD12	
J	21 GND	66 DMA6										82 PMD11	41 PMD10	
H	20 VDD	65 DMA8	94 DMA7							98 PMD9	83 PMD8	42 GND		
G	19 DMA9	64 DMA11	93 DMA10							99 PMD6	84 PMD7	43 VDD		
F	18 DMA12	63 DMA13	92 DMD15							100 PMD3	85 PMD4	44 PMD5		
E	17 DMD14	62 DMD13										86 PMD2	45 GND	
D	16 DMD12	61 DMD11										87 PMD0	46 PMD1	
C	15 DMD10	60 DMD9	INDEX PIN				91 IRQ0	90 IRQ2	89 PMA11				88 PMA2	47 PMA0
B	14 DMD8	59 DMD7	58 DMD6	57 DMD3	56 DMD1	55 IRQ1	54 IRQ3	53 PMA12	52 PMA9	51 PMA7	50 PMA6	49 PMA4	48 PMA1	
A	13 GND	12 DMD5	11 DMD4	10 DMD2	9 DMD0	8 GND	7 VDD	6 PMA13	5 PMA10	4 PMA8	3 GND	2 PMA5	1 PMA3	

129-189

Figure D-37. DSP U34 Pinout To Schematic Cross Reference-Bottom View

**D.7.14 Preprogrammed Components Programming Procedure.**

- a. Obtain the appropriate, to the repaired MVP CCA configuration, MVS software diskette, or a master device IAW Table D-19, Table D-20., and Table D-21.

Table D-19. MVP CCA AY6707288-3 Programmed Components

REF. DES	MICROCIRCUIT	RD6707416-0 FILE NAME	BLANK COMPONENT
U13	MC6704717-0	MVSPPAL.JED	AT22V10-2OGM/BB3B
U24	MC6704720-0	MVSPLOW.HEX	WS27C256F-55 0MB
U25	MC6704719-0	MVSPMID.HEX	WS27C256F-55DMB
U26	MC6704718-0	MVSPHIGH.HEX	WS27C256F-55DMB

## ARMY TM 9-1290-365-24&P

Table D-20. MVP CCA AY6707288-1 Programmed Components

REF. DES	MICROCIRCUIT	RD6707416-0 FILE NAME	BLANK COMPONENT
U13	MC6704717-0	MVSPPAL.JED	AT22V10-20GM/BB3B
U24	MC6704720-1	PF10820.BL	WS27C256F-55DMB
U25	MC6704719-1	PF10820.BM	WS27C256F-55DMB
U26	MC6704718-1	PF10820.BH	WS27C256F-55DMB

Table D-21. MVP CCA AY67010314 Programmed Components

REF. DES	MICROCIRCUIT	RD670710945 FILE NAME	BLANK COMPONENT
U13	MC67010975	PF10314.JED	AT22V10-20GM/BB3B
U24	MC67010942	PF10314.BL	WS27C256F-55DMB
U25	MC67010943	PF10314.BM	WS27C256F-55DMB
U26	MC67010944	PF10314.BH	WS27C256F-55DMB

**NOTE**

Refer to programmer's manufacturer operating instructions.

- b. If using diskette, download the appropriate file to the programmer.
- c. If using master device, install it on the appropriate socket on the programmer and download its contents.
- d. Obtain a blank, unprogrammed microcircuit IAW appropriate table.
- e. Install the blank microcircuit on the programmer, and program the component.
- f. Remove the programmed component from programmer.
- g. Mark label with the same microcircuit part number and software version as the master device. Use label DAT-59-652-1 for U24, U25, U26, and DAT-50-652-1 for U13, or equivalent.
- h. Attach label to top of programmed component, covering window completely.

### D.7.15 Final Testing.

D.7.15.1 FINAL TESTING PROCEDURES. The final testing is performed on a reassembled UUT. The test setup provided in Figure D-33 shows the equipment used and cable hookup for the first procedural step.

D.7.15.2 TEST DATA SHEETS. The test data sheets in Table D-18 are to be reproduced locally, as required, for recording the test results. The test data sheets must be completed each time a test section is performed. The completed test data sheets shall be retained.

### D.7.15.3 PREPARATION FOR TEST.

- a. Energize and adjust DMM to measure DC volts.
- b. Set ACCL switch on the test fixture to OFF position.
- c. Set switch S1 on the test fixture to DOP.OUT position.
- d. Set switch S6 on the test fixture to MVP-11 position.

- e. Set switch S3 on the test fixture to 4MHZ position.
- f. Set switch S4 on the test fixture to DOPP position.
- g. Before connecting the UUT to the test setup, verify that the text fixture is deenergized.
- h. Connect the UUT to the test setup IAW Figure D-33.

D.7.15.4 FINAL TESTING.

Perform the final testing IAW para. D.7.12.3 through D.7.12.7.



**SECTION VIII. ELECTRO-MAGNETIC INTERFERENCE  
(EMI) FILTER MODULE, PINs AY6707289-1 and  
AY6707289-3**

**SECTION CONTENTS**

<b>Subject</b>	<b>Page</b>
General.....	D-107
Test Equipment and Special Tools Required.....	D-107
Materials Required.....	D-107
General Repair Requirements.....	D-107
EMI Filter Module Removal.....	D-107
Cleaning.....	D-107
Visual Inspection.....	D-108
Repair.....	D-108
Painting.....	D-108
EMI Filter Module Installation.....	D-108
Testing.....	D-108

**D.8 ELECTRO-MAGNETIC INTERFERENCE (EMI) FILTER MODULE, P/NS AY6707289-1 AND AY6707289-3.**

**D.8.1 General.** This section provides repair procedures and maintenance information for the EMI filter module, P/Ns AY6707289-1 and AY6707289-3. Source, maintenance, and recoverability code is PADZZ.

**D.8.2 Test Equipment and Special Tools Required.** Test equipment and special tools requirements are listed in Table D-22. Unless otherwise specified, the test equipment and special tools listed below will be used for testing the EMI filter module. Each commercially available item of test equipment can be replaced by equipment equivalent to that listed.

*Table D-22. Test Equipment and Special Tools Required*

<b>Nomenclature</b>	<b>Part/Spec. No.</b>	<b>Figure</b>
Digital Multimeter (DMM)	Fluke, Model 77-2	C-11, 5
Electronic Equipment Tool kit	PPL863	C-11, 11
ESD Work Station kit	M87893-02	C-11, 13

**D.8.3 Materials Required.** No repair materials or other consumable items are required.

**D.8.4 General Repair Requirements.** None.

**D.8.5 EMI Filter Module Removal.** If necessary, remove EMI filter module IAW para. D.4.6.9.

**D.8.6 Cleaning.** Refer to para. 3.1.3 in Chapter 3 of this manual.

**D.8.7 Visual Inspection.** Refer to Figures D-38. and D-39.

- a. Inspect connectors for damaged pins and foreign matter.
- b. Inspect all components for secure attachment.
- c. Inspect all parts for damage, wear, and deterioration.
- d. Inspect all parts for nicks, scoring, dents, scratches, and broken runs.
- e. Inspect all electronic components for indication of overheating, cracked bodies, loose terminals, broken leads, cold solder joints, and other indications of damage or deterioration.
- f. Inspect all wiring for bent or broken leads, cracked, frayed, deteriorated, worn, overheated or burnt insulation, and security of attachment. Check lacing for secure attachment.

**D.8.8 Repair.** The EMI filter module is a nonrepairable item. No repair is authorized. When unserviceable, condemn and dispose of the item.

**D.8.9 Painting.** No painting required on EMI filter module.

**D.8.10 EMI Filter Module Installation.** Install EMI Filter Module IAW para. D.4.11.1.

**D.8.11 Testing.**

D.8.11.1 GENERAL.

- a. The EMI filter module testing is a continuity check.
- b. The test data sheet in Table D-23. are to be reproduced locally, as required, for recording the test results. The test data sheets must be completed each time a test section is performed. The completed test data sheets shall be retained.

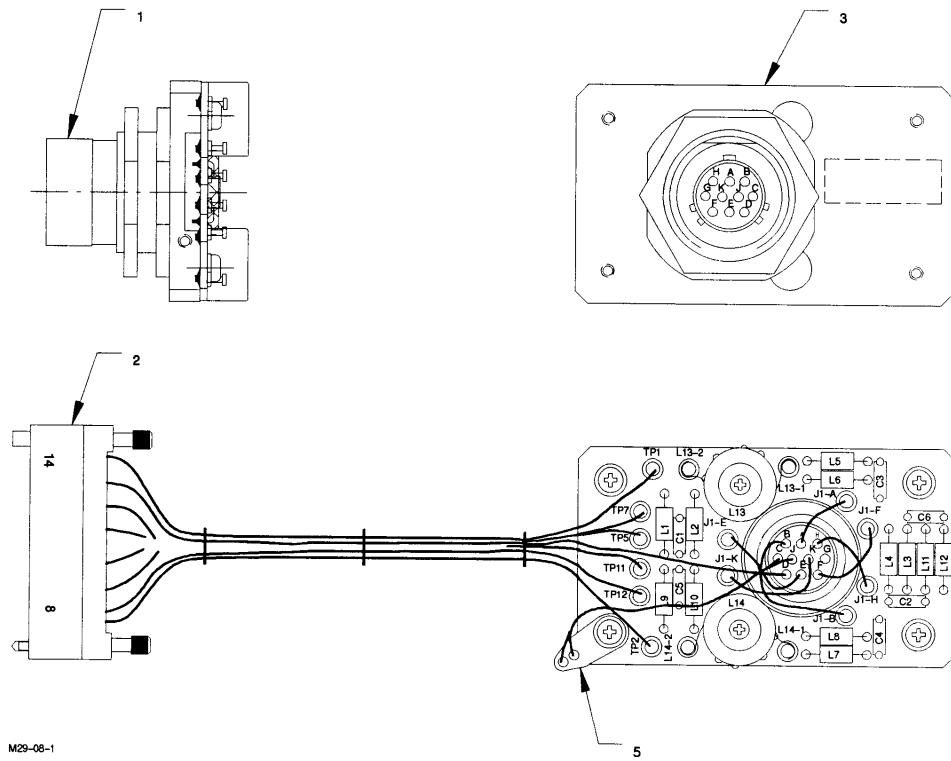

Figure D-38. EMI Filter Module, AY6707289-1

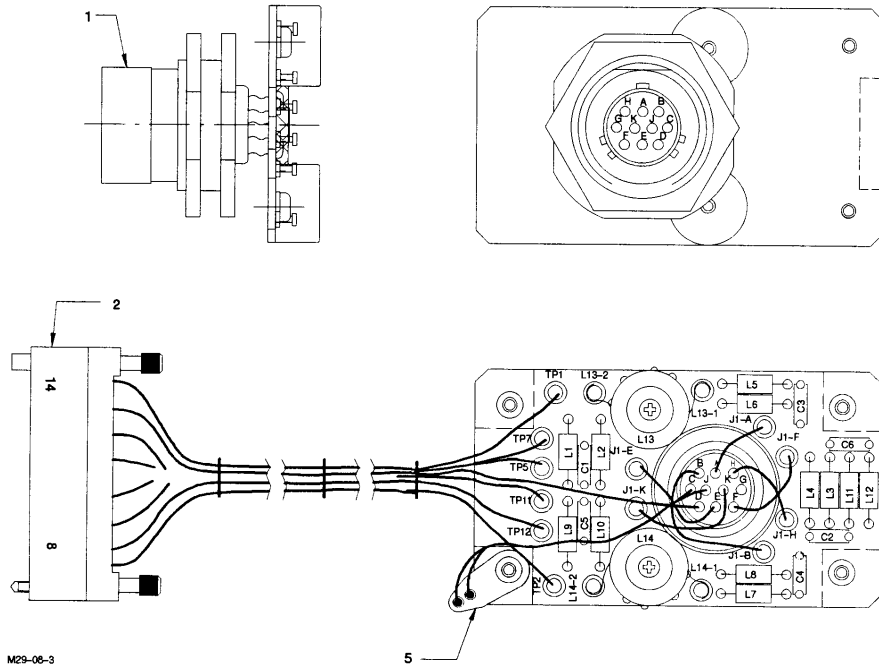

Figure D-39. EMI Filter Module, AY6707289-3



D.8.1 1.2 TEST SETUP.

- a. Energize the digital multimeter (DMM) and adjust it to "Ohms X 1" resistance mode.
- b. Zero DMM to eliminate internal resistance of the DMM and test leads.

D.8.1 1.3 CONTINUITY TEST. Check wiring using the DMM IAW Table D-23. If failed, condemn and dispose of the item.

*Table D-23. EMI Filter Module P/N AY6707289-1 and AY6707289-3 Continuity Test Data Sheet*

<b>From</b>	<b>To</b>	<b>Expected Resistance</b>	<b>Measured Resistance</b>
J1-E	J3-7	Less than 0.5 Ohm	
J1-F	J3-5	Less than 0.5 Ohm	
J1-A	J3-1	Less than 0.5 Ohm	
J1-B	J3-2	Less than 0.5 Ohm	
J1-K	J3-12	Less than 0.5 Ohm	
J1-H	J3-11	Less than 0.5 Ohm	
J1-D	J3-14	Less than 0.5 Ohm	
J1-C	E1	Less than 0.5 Ohm	
J1-J	E1	Less than 0.5 Ohm	

Tested by: \_\_\_\_\_

Inspected by: \_\_\_\_\_

Date: \_\_\_\_\_



**SECTION IX. MICROWAVE TEST EQUIPMENT,  
DESCRIPTION AND CALIBRATION**

**SECTION CONTENTS**

<b>Subject</b>	<b>Page</b>
General.....	D-113
Operation Description .....	D-113
Test Equipment Calibration.....	D-1 17

**D.9.1 General.**

D.9.1 .1 SCOPE. This section describes the microwave test equipment (MTE) that is used for testing of the M93 transceiver assembly P/N's AY6707292-O, AY6707292-4, and AY6707292-5. This MTE is also used on testing the M94 transceiver assembly P/N's AY6706571-O and AY6706571-2. For the M94 transceiver assembly, refer to TM 9-1290-364-24&P, Appendix D, Section 10.

D.9.1.2 PURPOSE. The purpose of this section is to provide the calibration and maintenance procedures for the MTE.

D.9.2 Operation Description.

D.9.2.1 PURPOSE. The purpose of the MTE is to demonstrate that the RF Section of the transceiver assembly complies with the requirements.

D.9.2.2 TESTED REQUIREMENTS. The following performance requirements of the transceiver assembly are tested using the MTE:

- a. Transmitted power
- b. Transmitted frequency
- c. Receiver sensitivity

D.9.2.3 EQUIPMENT DESCRIPTION. The MTE is composed basically of two types of equipment:

- a. Standard Measurement Equipment (SME)
- b. Microwave Measurement Equipment (MME)

D.9.2.3.1 STANDARD MEASUREMENT EQUIPMENT. Unless otherwise specified, the standard measurement equipment (SME) listed in Table D-24. is used for testing the transceiver assembly. Each SME can be replaced by equipment equivalent to the one listed with same or better performance.

**ARMY TM 9-1290-365-24&P**

*Table D-24. Standard Measurement Equipment*

<b>Nomenclature</b>	<b>Part/Spec. No.</b>	<b>Figure</b>
Microwave Frequency Counter	EIP Model 535	C-11, 22
Function Generator	Wavetek, Model 178	C-11, 23
Oscilloscope	Hewlett Packard, Model 1070B	C-11, 17
Power Supply, DC (0-40V, 5A)	Lambda, LLS-9040	C-11, 24
Power Supply, DC (0-40V, 1 A) 2 each	Lambda, LLS-5040	C-11, 25
Coaxial Cable, BNC, Male-To—Male, 50 (2 (3)	Local Manufacture	N/A
RMS Voltmeter	Hewlett-Packard, Model 3400A	C-11, 26
Power Meter	Hewlett-Packard, Model 432B	C-11, 27
Thermistor Mount	Hewlett-Packard, Model 84788	C-11, 28

D.9.2.3.2 Microwave Measurement Equipment.

D.9.2.3.2.1 Connection.

The microwave measurement equipment (MME) is listed in Table D-25. and should be connected as described in Figure D-40. prior to testing of the transceiver assembly. It should be calibrated for overall insertion loss for power and sensitivity measurements.

*Table D-25. Microwave Measurement Equipment*

<b>Nomenclature</b>	<b>Part/Spec. No.</b>	<b>Figure</b>
Coaxial Cable, SMA, Male-To-Male, 50 ohm (3)	Local Manufacture	N/A
Coaxial Cable, SMC Female/BNC Male, 50(2	Local Manufacture	N/A
WR90/SMA Female Adapter (4)	Midwest Microwave, 3625	C-11,42
Pin Switch	General Microwave, Model 9114	C-11,42
Phase Shifter	Midisco, Model MDC1 089-1	C-11,42
Fixed Coaxial Attenuator, 20dB	Weinschel, Model 4M	C—11, 30
Variable Waveguide Attenuator	Hewlett-Packard, Model X382A	C-11,42
Waveguide Directional Coupler	Hewlett-Packard, Model X752D	C-11,42
Termination, 50 ohm	Midwest Microwave, 2444M	C11,42
SMA Female/SMA Female Adapter	Midwest Microwave, 2595	C-11,31
N-Type Female/SMA Male Adapter	Midwest Microwave, 2682	C-11,42

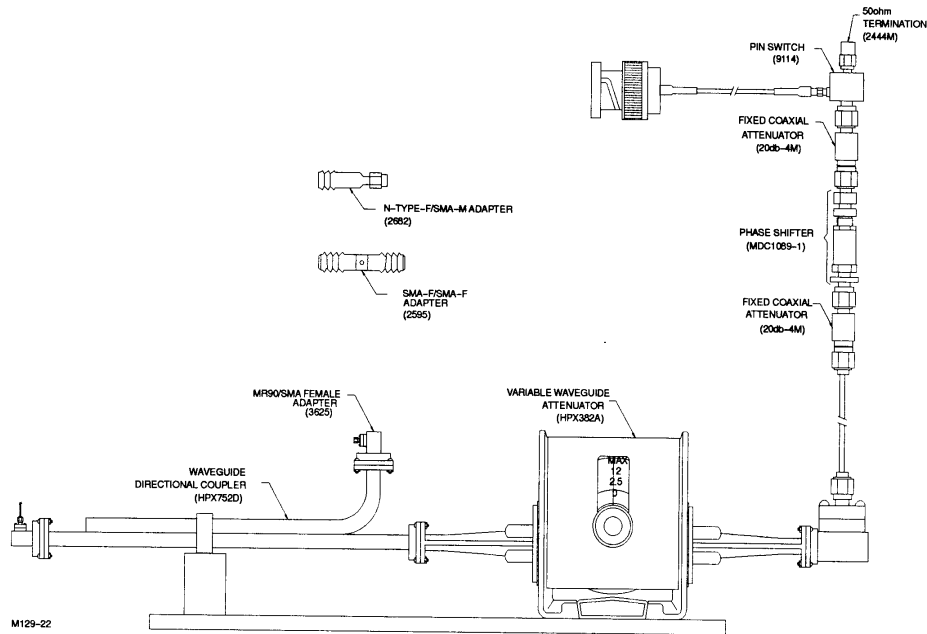

Figure D-40. Microwave Measurement Equipment Connection

Figure D-40. Microwave Measurement Equipment Connection

D.9.2.4 SENSITIVITY MEASUREMENTS THEORY OF OPERATION. The transceiver assembly transmits a low power X-band continuous wave signal. The transmitted signal strikes the outgoing projectile in flight and the reflected RF energy is received by the antenna. The reflected signal is different from the transmitted, due to the Doppler effect. The antenna unit detects the difference between the transmitted and received signals, which is directly relative to the projectile velocity.

In order to achieve the simulation of the outgoing projectile, the transmitted signal is reflected and modulated, so that the received frequency is within the velocity measuring range of the transceiver assembly. This is obtained by modulating a PIN switch in the microwave section at the appropriate frequency. The PIN switch is modulated by a square wave that causes it to switch from off to on and vice versa. When the PIN switch is off, the transmitted signal is reflected back to the antenna. When the PIN switch is on the signal is absorbed by the dummy load. Because of the square wave modulation, the reflected signal contains several spectral components. The first spectral component corresponds to the Doppler shifted frequency.

The first spectral component power, in accordance with Fourier transform theory, is  $1/11^2$  (-9.94dB) of the transmitted power.

Also, as a result of the on/off chopping of the signal and the absorption by the dummy load, only 1/2 (-3dB) of the transmitted power is reflected.

## ARMY TM 9-1290-365-24&P

### D.9.2.5 DETAILED DESCRIPTION.

D.9.2.5.1 Transmitted Frequency and Power Tests. The transmitted frequency and power tests are performed using a directional coupler and a variable attenuator. Those two components are connected together during the tests because they are waveguide components and must be hardware connected. This setup has waveguide-to-SMA adapters to provide easy connection to the unit under test (UUT) and to other test equipment.

When the frequency counter is connected to the coupling output of the directional coupler, the transmitted frequency is measured.

When the power meter is connected to the coupling output, the transmitted power is measured. The power which enters the power meter is attenuated by the coupling attenuation of the directional coupler. To get the real transmitting power, the coupling attenuation is added to the power measured by the power meter. The equation for the transmitted power calculation is:

$$PT = Pt + Kp$$

where:

PT = transmitted power in dBm

Pt = measured power in dBm

Kp = coupling attenuation factor in dB

D.9.2.5.2 Receiver Sensitivity. The microwave section (including all adapters and SMA cables) is installed permanently and is calibrated for its overall insertion loss. The overall insertion loss is due to insertion losses of the components and reflection losses between components.

The receiver sensitivity is defined as the received (reflected) power required to achieve a signal at the output of the transceiver which is 3dB greater than the noise level at the output when no signal is received. The equation for the receiver sensitivity calculation is:

$$S = PT - Ks - 2A$$

where:

S = receiver sensitivity in dBm

PT = transmitted power in dBm

Ks = overall insertion loss factor in dB

A = attenuation of the variable attenuator in dB

The receiver sensitivity test is performed in 5 steps:

- a. The output signal is adjusted to maximum reflected signal by the phase shifter.
- b. The transmitted power is measured on the power meter.
- c. The output noise level is measured on the RMS voltmeter.
- d. The reflected signal is adjusted, using the variable attenuator, to get an output signal which is 3dB greater than the noise level.
- e. The receiver sensitivity is calculated using the above equation.

#### NOTE

The attenuation of the variable attenuator is multiplied by 2 because the signal is attenuated twice, once when it is transmitted forwards and once again when it is reflected backwards.

The transceiver is connected to the directional coupler. The transmitted power is measured through the coupling output as described in paragraph D.9.2.5.1. The transmitted signal passes towards the modulated PIN switch where it is reflected or absorbed by the dummy load (see paragraph D.9.2.4). The PIN

switch is modulated by a frequency in the measurement range. The variable attenuator allows adjustment of the reflected signal to a desired level. The phase shifter is used to adjust the reflected signal phase to the transmitted signal phase. The 40dB fixed attenuator allows operating at the mid-scale of the variable attenuator, and not at its scale's edge.

The attenuation of the fixed attenuator is included in the overall insertion loss factor.

The output signal is transferred to the oscilloscope and RMS voltmeter for measurement.

D.9.3 Test Equipment Calibration.

D.9.3.1 SME CALIBRATION. The standard measurement equipment is calibrated in accordance with MIL-STD-45662.

D.9.3.2 MME SPECIAL CALIBRATION.

a. The MME for receiver sensitivity is calibrated for overall insertion loss. Refer to Figure D-41. for schematic description of calibration connection.

b. The calibration data sheets, Table D-26., are to be reproduced locally, as required, for recording the calibration results. The calibration data sheets must be completed each time a calibration is performed. The completed calibration data sheets shall be retained.

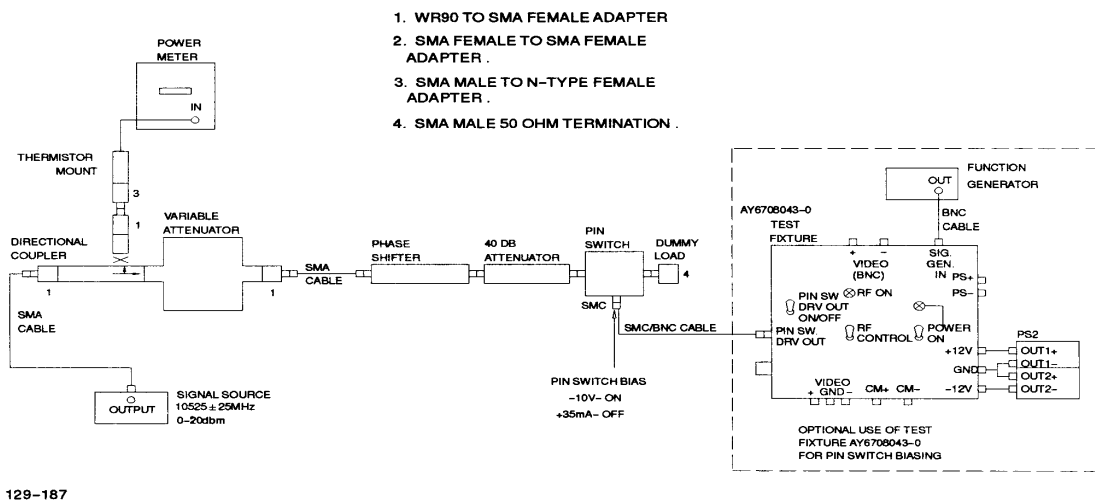

Figure D-4 1. Microwave Measurement Equipment Calibration Schematic

D.9.3.2.1 Special Calibration Requirements. The calibration of the microwave test equipment is performed in 3 steps:

- a. Insertion loss without the PIN switch.
- b. Return loss of the PIN switch.
- c. Calculation of overall insertion loss.

## ARMY TM 9-1290-365-24&P

D.9.3.2.2 Insertion Loss Without PIN Switch. The calibration of the microwave measurement equipment setup is performed in the following way:

- a. The PIN switch and dummy load are disconnected from the test setup.
- b. A power meter is connected to the coupling output of the directional coupler and to the output of the 20dB fixed attenuator.
- c. A signal source of 0 to 20dBm power ( $P_i$ ) and frequency of  $10525 \pm 25$  MHz is inserted through the SMA female/female adapter.
- d. The variable attenuator is set to 0dB attenuation.
- e. The phase shifter is adjusted for maximum power on the fixed attenuators output.
- f. The power on the fixed attenuator output and the coupling output are recorded.

$P_c$ (dBm) = Coupling output

$P_a$ (dBm) = Fixed attenuator output

- g. The insertion loss for both outputs is calculated:

$K_p = P_i - P_c$  (coupling attenuation factor in dB)

$K_a = P_i - P_a$  (insertion loss at fixed attenuator output in dB)

$P_i$  = input power from the signal source in dBm

D.9.3.2.3 Return Loss of the PIN Switch. The PIN switch is tested for its return loss (RL) when the switch is off. The OFF position is defined while the PIN SW is set to isolate between input and output port, and reflect the power to the input port. The PIN switch is biased in accordance with its manufacturers requirements during tests.

### NOTE

For this test, the PIN SW. output of the test fixture AY6708043-0 can be used to bias the tested PIN switch. Refer to Figure D-41 .

D.9.3.2.4 Calculation of Overall Insertion Loss. The overall insertion loss of the microwave test equipment setup is calculated as follows:

$K_s = 2 \times K_a + RL + 3dB + 9.94dB$

where:

$K_s$  = overall insertion loss factor in dB

2 = multiplier for a signal travelling both ways

$K_a$  = insertion loss of the microwave test equipment setup as was previously measured

RL = return loss of the PIN switch in dB

3dB = correction for -3dB power reflection as a result of on/off chopping of the signal by the PIN switch.

9.94dB = correction for -9.94dB in reflected power as a result of the first spectral component.

D.9.3.2.5 Factor Marking. The coupling attenuation factor ( $K_p$ ) and the overall insertion loss factor ( $K_s$ ) are marked using a sticker on the directional coupler as follows:

$K_p = XX.XdB$

$K_s = XX.X dB$

XX.X = the result achieved after calculations.

END OF CALIBRATION



Table D-26. MME Calibration Data Sheet

Para.	Description	Measured/Calculated Result
D.9.3.2.2	Insertion Loss	
D.9.3.2.2c.	Pi (dBm)	
	Pi (MHz)	
D.9.3.2.2f.	Pc (dBm)	
	Pa (dBm)	
D.9.3.2.2g.	Kp (dBm)	
	Ka (dBm)	
D.9.3.2.3	Return Loss RL (dB)	
D.9.3.2.4	Overall insertion loss Ks (dB)	
D.9.3.2.5	Factor marking mark Kp and Ks	

Tested by: \_\_\_\_\_

Inspected by: \_\_\_\_\_

Date: \_\_\_\_\_



APPENDIX E

GLOSSARY

APPENDIX CONTENTS

Subject	Page
Abbreviations and Acronyms .....	E-1
Special Terms .....	E-3

**E.1 ABBREVIATIONS AND ACRONYMS.**

The following abbreviations and acronyms are used in this manual:

Term	Definition
A .....	Ampere
ADDR .....	Address
AFCS .....	Automatic Fire Control System
ANT .....	Antenna
AUX .....	Auxiliary
BCD .....	Binary Coded Decimal
BIT .....	Built-in Test
BNC .....	Bayonet-Coupled
CCA .....	Circuit Card Assembly
CKT .....	Circuit
CMD .....	Command
CMOS .....	Complementary Metal Oxide Semiconductor
CNT .....	Count
COMM .....	Communication
CPC .....	Corrosion Prevention and Control
CS .....	Chip Select
DB .....	Decibels
DIFF .....	Differential
DMA .....	Data Memory Address
DMD .....	Date Memory Data
DMM .....	Digital Multimeter
DOPP .....	Doppler
DSP .....	Digital Signal Processor
EEPROM .....	Electrically Erasable Programmable Read-Only Memory
EIR .....	Equipment Improvement Recommendation

E.1 ABBREVIATIONS AND SYMBOLS (Cont.)

Term	Definition
EMI .....	Electromagnetic Interference
EPROM .....	Erasable Programmable Read-Only Memory
ESD .....	Electrostatic Discharge
ESDS .....	Electrostatic Discharge Sensitive
EXT .....	External
FDOPP .....	Doppler Frequency
FFT .....	Fast Fourier Transform
FSC .....	Federal Supply Class
ft lb .....	foot pound
GEN .....	Generator
GND .....	Ground
Hz .....	Hertz (cycles per second)
IAW .....	In Accordance With
in .....	inch
in. lb .....	inch pound
I/O .....	Input/Output
K .....	Kilobyte
kHz .....	kilohertz
mA .....	Milliamp
MAC .....	Maintenance Allocation Chart
MAX .....	Maximum
Mhz .....	Megahertz
MIL-STD .....	Military-Standard
Min .....	Minimum
ms .....	milliseconds
m/sec .....	Meters Per Second
MSR .....	Measure
MTOE .....	Modified Table of Organization and Equipment
MV .....	Muzzle Velocity
MVM .....	Muzzle Velocity Management
MVP .....	Muzzle Velocity Processor
MVS .....	Muzzle Velocity System
mW .....	milliwatts
NSN .....	National Stock Number
N.m .....	Newton meter
PMA .....	Program Memory Address
PMD .....	Program Memory Data
PMDA .....	Program Memory Data Address
POST .....	Power-on Self Test
PS .....	Power Supply
P-P .....	Peak-to-Peak
PWB .....	Printed Wiring Board
PWM .....	Pulse Width Modulation
PWR .....	Power
RAM .....	Random Access Memory
REG .....	Regulator

**E.1 ABBREVIATIONS AND SYMBOLS (Cont.)**

<b>Term</b>	<b>Definition</b>
RET .....	Return
RF .....	Radio Frequency
RPSTL .....	Repair Parts and Special Tools List
RFI .....	Radio Frequency Interference
SIG .....	Signal
SOP .....	Standard Operating Procedure
SRU .....	Shop Replaceable Unit
SYNTH .....	Synthetic
TBD .....	To Be Determined
TEMP .....	Temperature
TFT .....	Tabular Firing Table
TM .....	Technical Manual
TMDE .....	Test, Measurement, and Diagnostic Equipment
TRIG .....	Trigger
TXD .....	Transit Data
UUT .....	Unit Under Test
V .....	Volt
VAC .....	Volts - Alternating Current
VBAT .....	Battery Voltage
VCC .....	TBD
VDC .....	Volts - Direct Current
VIN .....	Voltage In
μA .....	Microamp

**E.2 SPECIAL TERMS.**

The following special terms are used in this manual:

<b>Term</b>	<b>Definition</b>
Doppler Effect .....	The change in the observed frequency of an electro-magnetic wave due to relative motion of source and observer.
Doppler Radar .....	A radar that makes use of the Doppler shift of an echo due to relative motion of target and radar to differentiate between fixed and moving targets and measure target velocities.
Microstrip .....	A strip transmission line that consists basically of a thin-film strip in intimate contact with one side of a flat dielectric substrate, with a similar thin-film ground-plane conductor on the other side of the substrate.
RS-232 .....	A standard developed by the Electronic Industries Association that governs the interface between data processing and data communication equipment. Used to connect microcomputers to peripheral devices.



---

**APPENDIX F****EXPENDABLE AND DURABLE ITEMS LIST**

---

**SECTION I. INTRODUCTION****F 1 SCOPE.**

This appendix lists expendable and durable items you will need to operate and maintain the M93 MVS. This listing is for information only and is not authority to requisition the listed items. These items are authorized to you by CTA 50-790, Expendable/Durable Items (except medical, class V repair parts, and heraldic items), or CTA 8-100, Army Medical Department Expendable/Durable Items.

**F 2 EXPLANATION OF COLUMNS.**

- a. **Column 1. Item Number.** This number is assigned to the entry in the listing and is referenced in the narrative instructions to identify the item (e.g. "Use cleaning compound, item 5, appendix F").
- b. **Column 2. Level.** This column identifies the lowest level of maintenance that requires the item.
- c. **Column 3. National Stock Number.** This is the National stock number assigned to the item which can use to requisition it.
- d. **Column 4. Item Name, Description, Contractor and Government Entity Code (CAGEC), and Part Number.** This provides the other information you need to identify the item.
- e. **Column 5. Unit of Measure.** This code shows the physical measurement or count of an item, such as gallon, dozen, gross, etc.

ARMY TM 9-1290-365-24&P

(1) Item Number	(2) Level	(3) National Stock Number	(4) Item Name, Description CAGE Code, & Part Number	(5) (U/M)
1	O	6810-00-194-9477	ACETONE (81348) 0A51	PT
2	O	8040-01-147-9957	ADHESIVE (06090) S1125	GR
3	O	8040-00-947-5483	ADHESIVE (06090) S1184	OZ
4	F	6810-01-136-7012	ALCOHOL, ISOPROPYL 1 gal bottle, grade A (81348) TT-I-735A	GL
5	O	6145-00-811-5224	WIRE (81349) MIL-W-16878/4BHE9	FT
6	F	7920-00-514-2417	BRUSH, ACID (81348) H-B-643	GR
7	O	7920-00-140-0869	CLOTH, LINT-FREE (03950) 8722-0088	BX
8	F	3439-00-220-3827	FLUX, SOLDERING Type RMA (81349) MIL-F-14256	PT
9	O	5970-00-090-9184	INSULATION COMPOUND, ELECTRICAL Type 1B31 (81349) MIL-I-46058	PT
10	F	7530-01-119-2563	LABEL (16956) 43-143	BX
11	O	5970-00-001-9356	LACING TAPE (81349) MIL-T-43435-B3BLK	RO
12	O	8030-00-555-2879	LOCKING COMPOUND Grade E, 250 cc bottle (81349) MIL-S-22473	CC
13	O	6145-00-160-4775	WIRE, BUS (81349) QQ-W-343/S-22-S1T	LB
14	O	6810-00-264-8983	METHYL ETHYL KETONE (81346) ASTM-D-740	OZ
15	O	6145-00-838-9444	WIRE, BUS (81349) QQ-W-343/S-26-S1T	LB
16	O	8030-00-081-2330	SEALING COMPOUND (05972) 83-31	OZ
17	O	8030-00-082-2508	PRIMER, SEALING COMPOUND (05972) 747-55	OZ



(1) Item Number	(2) Level	(3) National Stock Number	(4) Item Name, Description CAGE Code, & Part Number	(5) (U/M)
18	O	7920-00-205-1711	RAG, WIPING 50 lb (22.68 kg) bale (58536)	LB
19	O	8040-00-144-9774	SEALANT, ADHESIVE 12 oz (340.2 gr) cartridge (81349) MIL-A-46146	OZ
20	O	8030-00-081-2340	SEALING COMPOUND Grade AA (81349) MIL-S-22473	CC
21	O	8010-01-055-2319	PAINT, CARC (81349) MIL-C-46168 COLOR 383 IAW FED-STD-595	PT
22	O	6850-00-109-4362	SILICONE COMPOUND (81349) MIL-C-47113	PT
23	O	3439-01-046-1471	SOLDER, TIN ALLOY QQ-S-571 (81348) 5N63WRMAP3	LB
24	O	5310-00-933-8119	WASHER, LOCK (96906) M535338-137	HD
25	O	5970-01-331-4831	TUBING, INSULATING (81349) M22129-22-N	EA
26	O	5970-01-390-0997	SLEEVE, HEAT SHRINK (81349) M23053/5-107-9	FT
27	O	5970-01-351-6799	SLEEVE, HEAT SHRINK (81349) M23053/18-202-C	FT
28	F	5905-01-186-6858	Resistor Fixed 81349 RLR07C750GS	EA



## APPENDIX G

### INSTRUCTIONS ON HOW TO USE THIS FORM

**REFERENCE:** Website <http://lrc3.monmouth.army.mil/cecom/lrc/pie/word/da2407.dot>

1. Copy this template (da.2407.dot) into your template folder (i.e. C:\Program Files\Microsoft Office\Templates). If you do know where you templates are, follow these steps:
  - a. Open Windows Explorer (Windows 95).
  - b. Select , "Find", "Files" or "Folders".
  - c. On the "Name & Location" Tab enter "\*.dot" without the quotes in the "Names" box
  - d. Enter "(C)" in the location box.
  - e. Make sure "include subfolders" is checked, the click on "FIND NOW", a list of all files with a .dot extension will appear in the bottom box, with the path to these files. Choose the path for normal .dot.
2. Open Microsoft Word 97.
3. Select "File" then "New".
4. Under the "General" Tab you should see da2407.dot.
5. Either double click on DA 2407.doc OR click on da2407.doc, then OK.
6. You should now have a new document (i.e. Document1) open based on DA Form 2407.
7. Use the Tab key to move from block to block and type in the necessary information.
8. The blocks that have an arrow next to them are drop-down lists. To fill in these blocks, click on the arrow and then select the correct option (NOTE: some drop-down blocks have help at the bottom of you screen in the status bar to tell you what the options mean).
9. Once you have completed all of the blocks, use Print Preview (File, Print Preview). This will copy the information you typed on page one to copies 2 through 5.
10. You can now print the form or save it as a word document. (NOTE: If you do print the form, select pages 2-6, so you do not print out these directions).
11. If you do not have access to the Internet, you can reproduce the forms in this appendix and fill them out with a pen.

**ARMY TM 9-1290-365-24&P**

**HOW TO USE DA 2404 FORM**

**REFERENCE: Website <http://www.usapa.army.mil/forms/forms3.html>**

1. Use Form Flow to fill out form.
2. Print filled out form.
3. Send copy with item to be repaired.
4. Send copy to address in paragraph 3.1.9c.

<b>MAINTENANCE REQUEST</b>			PAGE NO.	NO OF PAGES	REQUIREMENT CONTROL SYMBOL CSGLD-1047(R1)
For use of this form, see DA PAM 738-750 and 738-751; the proponent agency is DCSLOG					
<b>SECTION I - CUSTOMER DATA</b>			<b>SECTION II - MAINTENANCE ACTIVITY DATA</b>		
1a. UIC CUSTOMER	1b. CUSTOMER UNIT NAME	1c. PHONE NO	3a. WORK ORDER NUMBER (WON)	3b. SHOP	3c. PHONE NO
2a. SAMS-2 UIC/SAMS-I/TDA	2b. UTILIZATION CODE	2c. MCSR	4a. UIC SUPPORT UNIT	4b. SUPPORT UNIT NAME	
<b>SECTION III - EQUIPMENT DATA</b>					
5. TYPE MNT REQ CODE	6. ID	7. NSN	15a. FAILURE DETECTED DURING/WHEN DISCOVERED CODE (Enter code) - See DA Pamphlet 738-750 and 738-751		
8. MODEL			15b. FIRST INDICATION OF TROUBLE/ HOW RECOGNIZED CODE (Enter Code) See DA Pamphlet 738-750 and 738-751		16. MILES/KILOMETERS/HOURS/ROUNDS M <input type="text"/> K <input type="text"/>
9. NOUN					H <input type="text"/> R <input type="text"/>
10a. ORG WON/DOC NO		10b. EIC			
11 SERIAL NUMBER	12. QTY	13. PD	17. PROJECT CODE (if assigned)	18. ACCOUNT PROCESSING CODE	19. IN WARRANTY? (enter Y or N) Y
14. MALFUNCTION DESCRIPTION (for DSU, GSU/AVIM, DEPOT use)		21. REIMBURSABLE CUSTOMER (if Intransit customer enter Y or N) Y		20. ADMIN NO	
		22. LEVEL OF WORK O	23. SIGNATURE		
24. DESCRIBE DEFICIENCIES OR SYMPTOMS ON THE BASIS OF COMPLETE CHECKOUT AND DIAGNOSTIC PROCEDURES IN EQUIPMENT TM (Do not prescribe repairs)					
25. REMARKS					
<b>PREPARATION INSTRUCTIONS FOR THIS PAGE</b>					
<b>SECTION I</b>			<b>SECTION III (Cont'd)</b>		
<p>Block 1a. Enter UIC of submitting organization.</p> <p>Block 1b. Enter name of submitting organization.</p> <p>Block 1c. Enter number to be called when maint. is completed.</p> <p>Block 2a. Enter UIC of supporting SAMS-2/SAMS-I/TDA if work is requested while in transit and away from your support maintenance unit.</p> <p>Block 2b. Enter utilization code. See DA Pamphlets 738-750 and 738-751.</p> <p>Block 2c. Enter "Y" if reportable under AR 700-138. If not, leave blank.</p>			<p>Block 12. Enter the quantity of items being submitted.</p> <p>Block 13. Enter the maintenance priority designator determined from DA PAM 710-2-1.</p> <p>Block 14. For DSU, GSU/AVIM, DEPOT use.</p> <p>Block 15a. Enter the code that most accurately describes when the fault or deficiency was detected. See DA Pamphlets 738-750 and 738-751.</p> <p>Block 15b. Select one. Enter the code. See DA Pamphlets 738-750 and 738-751.</p> <p>Block 16. Enter the accumulated usage data in blocks, when equipment is subject to usage reporting.</p> <p>Block 17. Enter the project code if one has been assigned. If not, leave blank.</p> <p>Block 18. See DA Pamphlets 738-750 and 738-751.</p> <p>Block 19. Enter "Y" or "N" to indicate whether equipment is still under manufacturer's warranty.</p> <p>Block 20. Enter the admin number assigned for property control purposes for the equipment being submitted.</p> <p>Block 21. For DSU/GSU/AVIM/Depot use.</p> <p>Block 22. Enter level of work performed "O" for UNIT LEVEL/AVUM, "F" for DSU/AVIM, "H" for GSU, "D" for DEPOT, "K" for contractor or "L" for Spc Rpr Act.</p> <p>Block 23. Enter the signature of the CO or the CO's designated representative when the priority designator is 01-10. For priority designators 11-15, leave blank.</p> <p>Block 24. Enter a brief description of the deficiencies or symptoms that you feel require attention at this level of maint.</p> <p>Block 25. Self-explanatory.</p>		
<b>SECTION II</b>					
Leave blank. To be completed by the support maintenance DSU/GSU/AVIM/DEPOT.					
<b>SECTION III</b>					
<p>Block 5. Enter the Type Maintenance Request Code. See DA Pamphlet 738-750 and 738-751.</p> <p>Block 6. Enter ID associated with block 7. See DA Pamphlets 738-750 and 738-751.</p> <p>Block 7. Enter the NSN or stock number of the item being submitted.</p> <p>Block 8. Enter model of item being submitted.</p> <p>Block 9. Enter noun/nomenclature of item being submitted.</p> <p>Block 10a. Enter Work Order Number (WON)/DOC NO assigned when item is submitted. Otherwise, leave blank.</p> <p>Block 10b. Enter End Item Code. See AMDF.</p> <p>Block 11. Enter serial number of item being submitted.</p>					
34a. SUBMITTED BY	35a. ACCEPTED BY	35c. DATE	<p>Block 34a. Enter first initial and last name of submitter.</p> <p>Block 34b. Enter ordinal date submitted (YYDDD).</p> <p>Block 35a. Enter first initial and last name of person accepting maint. request.</p> <p>Block 35b. Enter the initial status. See DA Pamphlets 738-750 and 738-751.</p> <p>Block 35c. Enter ordinal date accepted (YYDDD).</p> <p>Block 35d. Enter military time.</p>		
34b. DATE	35b. STATUS	35d. TIME			

MAINTENANCE REQUEST For use of this form, see DA PAM 738-750 and 738-751; the proponent agency is DCSLOG			PAGE NO.	NO OF PAGES	REQUIREMENT CONTROL SYMBOL CSGLD-1047(R1)						
<b>SECTION I - CUSTOMER DATA</b>			<b>SECTION II - MAINTENANCE ACTIVITY DATA</b>								
1a. UIC CUSTOMER	1b. CUSTOMER UNIT NAME	1c. PHONE NO	3a. WORK ORDER NUMBER (WON)	3b. SHOP	3c. PHONE NO						
2a. SAMS-2 UIC/SAMS-1/TDA	2b. UTILIZATION CODE	2c. MCSR	4a. UIC SUPPORT UNIT	4b. SUPPORT UNIT NAME							
<b>SECTION III - EQUIPMENT DATA</b>											
5. TYPE MNT REQ CODE	6. ID	7. NSN	15a. FAILURE DETECTED DURING/WHEN DISCOVERED CODE (Enter code) - See DA Pamphlet 738-750 and 738-751								
8. MODEL	9. NOUN		15b. FIRST INDICATION OF TROUBLE/ HOW RECOGNIZED CODE (Enter Code) See DA Pamphlet 738-750 and 738-751		16. MILES/KILOMETERS/HOURS/ROUNDS						
10a. ORG WON/DOC NO	10b. EIC		M	K							
11. SERIAL NUMBER	12. QTY	13. PD	H	R							
17. PROJECT CODE (if assigned)		18. ACCOUNT PROCESSING CODE	19. IN WARRANTY? (enter Y or N) Y		20. ADMIN NO						
14. MALFUNCTION DESCRIPTION (for DSU, GSU/AVIM, DEPOT use)		21. REIMBURSABLE CUSTOMER (if Intransit customer enter Y or N) Y O		23. SIGNATURE							
24. DESCRIBE DEFICIENCIES OR SYMPTOMS ON THE BASIS OF COMPLETE CHECKOUT AND DIAGNOSTIC PROCEDURES IN EQUIPMENT TM (Do not prescribe repairs)											
25. REMARKS											
26. TECHNICAL REFERENCES											
<b>SECTION IV - TASK REQUIREMENTS DATA</b>											
27a. FILE INPUT ACT CD	27b. TASK NO	27c. ACT CODE	27d. TASK DESCRIPTION	27e. QTY TO BE RPR	27f. WORK CENTER	27g. FAILURE CODE	27h. MH PROJ	27i. MH EXP			
<b>SECTION V - PART REQUIREMENTS</b>											
28a. FILE INPUT ACT CD	28b. TASK NO	28c. ID NO	28d. NSN OR PART NUMBER	28e. SFX CD	28f. QTY RQD	28g. QTY ISSUED	28h. NMCS CD	28i. FAILURE CODE	28j. STORAGE LOCATION	28k. INITIALS	28l. COST \$
28m. TOTAL MANHOURS			28n. TOTAL MANHOURS COSTS \$	28o. TOTAL PARTS COSTS\$							
<b>SECTION VI - COMPLETION DATA</b>											
29. QTY RPR		30. QTY CONDEMN	31. QTY NRTS	32. EVAC WON		33. EVAC UNIT NAME					
<b>SECTION VII - ACTION SIGNATURES</b>											
34a. SUBMITTED BY		35a. ACCEPTED BY	35c. DATE	36a. WORK STARTED BY		37a. INSPECTION BY			38a. PICKED UP BY		
34b. DATE	35b. STATUS	35d. TIME	36b. STATUS	36c. DATE	36d. TIME	37b. STATUS	37c. DATE	37d. TIME	38b. STATUS	38c. DATE	38d. TIME

### EQUIPMENT INSPECTION AND MAINTENANCE WORKSHEET

For use of this form, see DA PAM 738-750 and 738-751; the proponent agency is DCSLOG

1. ORGANIZATION				2. NOMENCLATURE AND MODEL			
3. REGISTRATION/SERIAL/NSN	4a. MILES	b. HOURS	c. BOUNDS FIRED	d. HOT STARTS	5. DATE	6. TYPE INSPECTION	
7. APPLICABLE REFERENCE							
TM NUMBER		TM DATE		TM NUMBER		TM DATE	
COLUMN a – Enter TM item number. COLUMN b – Enter the applicable condition status symbol COLUMN c – Enter deficiencies and shortcomings.				COLUMN d – Show corrective action for deficiency or shortcoming listed in Column c. COLUMN e – Individual ascertaining completed corrective action initial in this column.			
STATUS SYMBOLS							
"X" – Indicates a deficiency in the equipment that places it in an inoperable status.  CIRCLED "X" – Indicates a deficiency, however, the equipment may be operated under specific limitations as directed by higher authority or as prescribed locally, until corrective action can be accomplished.  HORIZONTAL DASH "-" – Indicates that a required inspection, component replacement, maintenance operation check, or test flight is due but has not been accomplished, or an overdue MWO has not been accomplished.				DIAGONAL "/" – Indicates a material defect other than a deficiency which must be corrected to increase efficiency or to make the item completely serviceable.  LAST NAME INITIAL IN BLACK, BLUE-BLACK INK, OR PENCIL – Indicates that a completely satisfactory condition exists.  FOR AIRCRAFT - Status symbols will be recorded in red.			
ALL INSPECTIONS AND EQUIPMENT CONDITIONS RECORDED ON THIS FORM HAVE BEEN DETERMINED IN ACCORDANCE WITH DIAGNOSTIC PROCEDURES AND STANDARDS IN THE TM CITED HEREON.							
8a. SIGNATURE (Person(s) performing inspection)			8b. TIME	9a. SIGNATURE (Maintenance Supervisor)		9b. TIME	10. MANHOURS REQUIRED
TM ITEM NO. <i>a</i>	STATUS <i>b</i>	DEFICIENCIES AND SHORTCOMINGS <i>c</i>		CORRECTIVE ACTION <i>d</i>		INITIAL WHEN CORRECTED <i>e</i>	





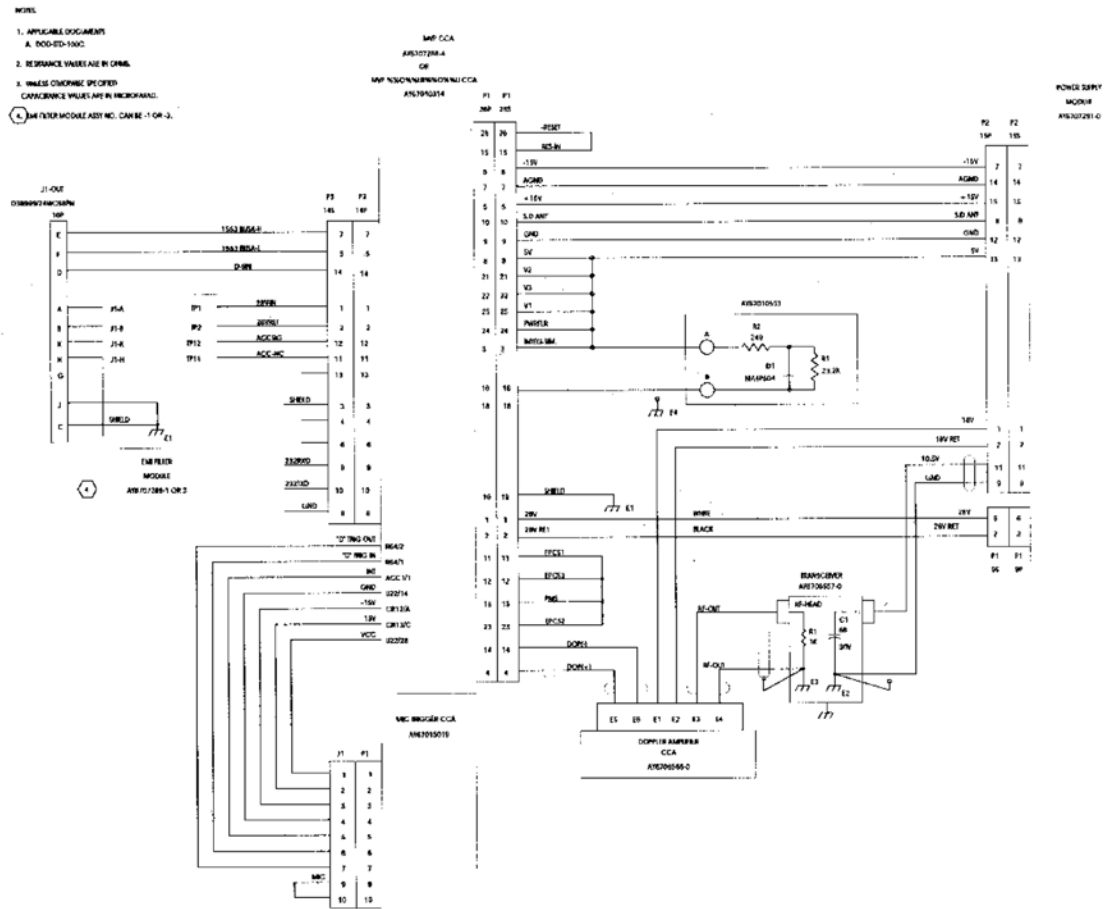



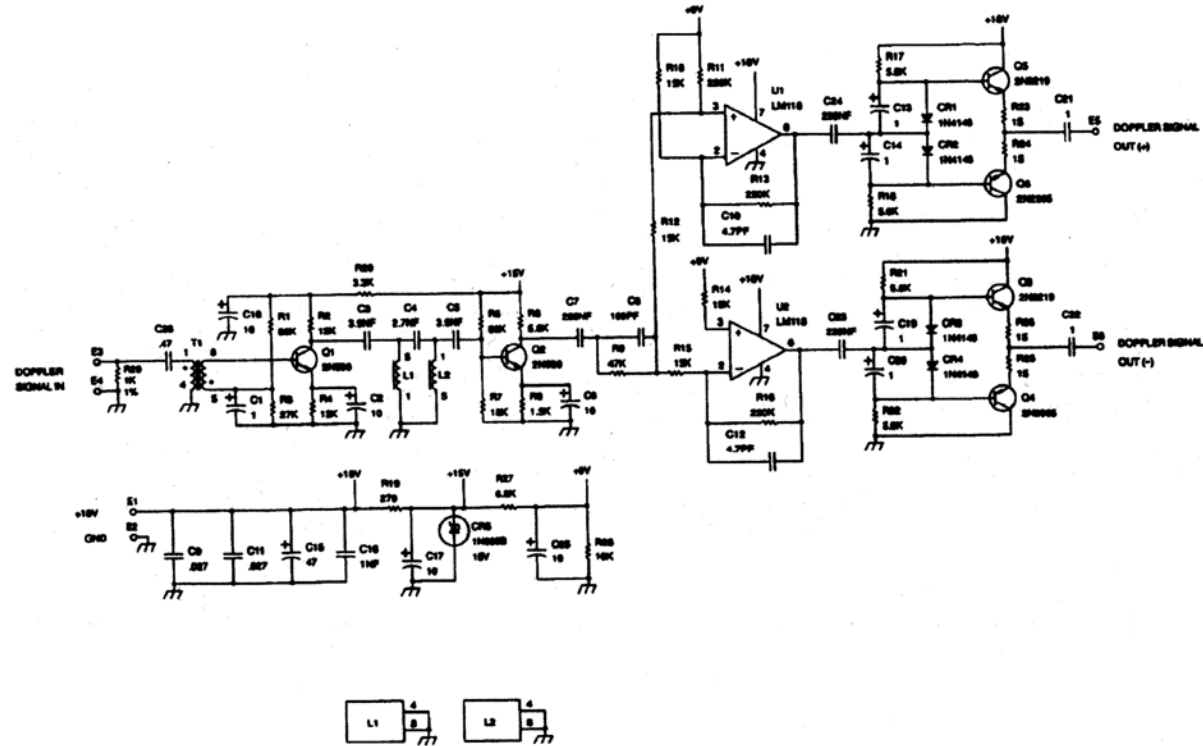

AV2888LD70884-0

FO-2. Doppler Amplifier CCA, PN AY6706566-0, Schematic Diagram

FO-3/(FO-4 blank)



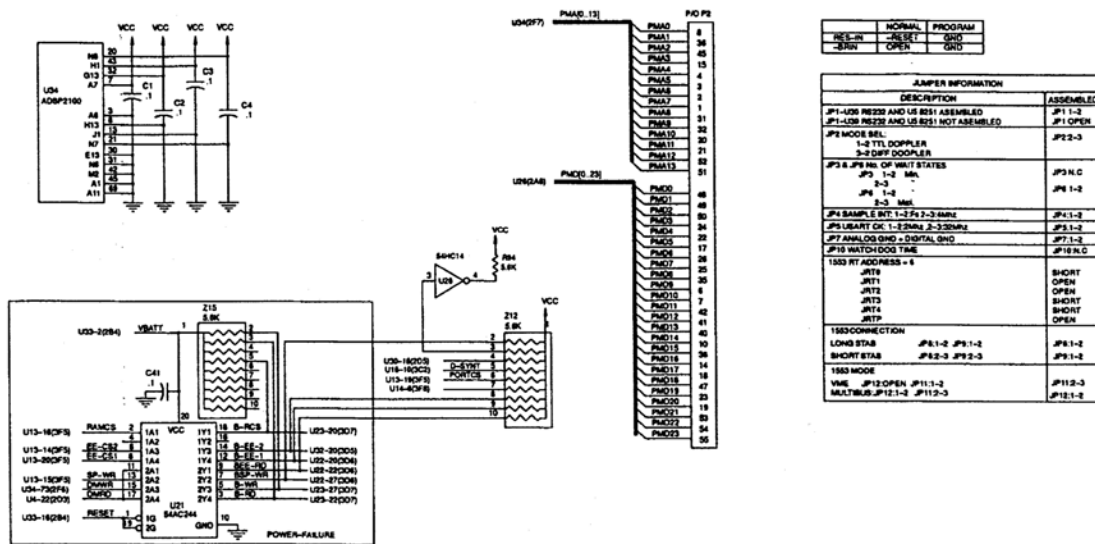

FO-3. MVP Processor CCA, PN AY6707288-0, Schematic Diagram (Sheet 1 of 4)



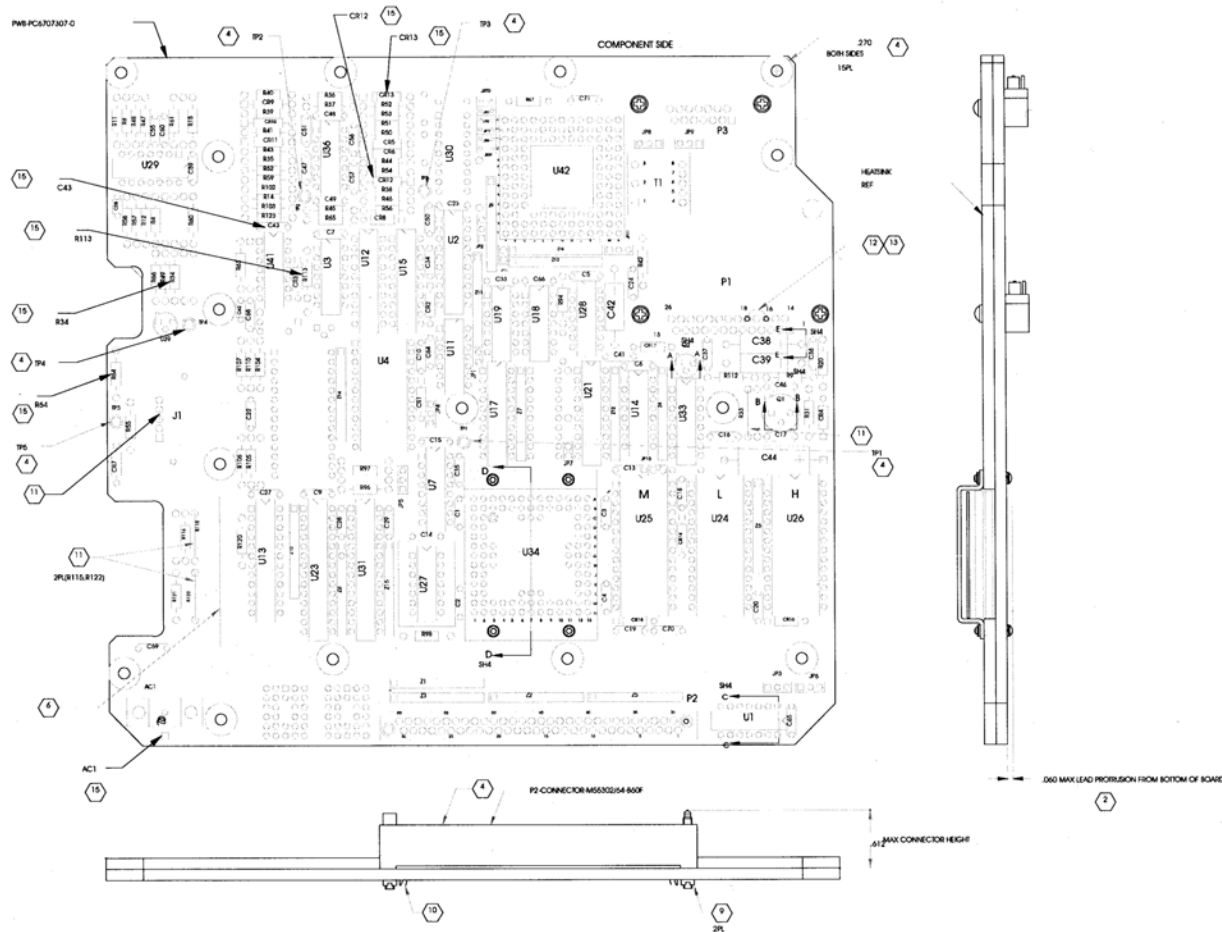

FO-3. MVP Processor CCA, PN AY6707288-0, Schematic Diagram (Sheet 2 of 4)





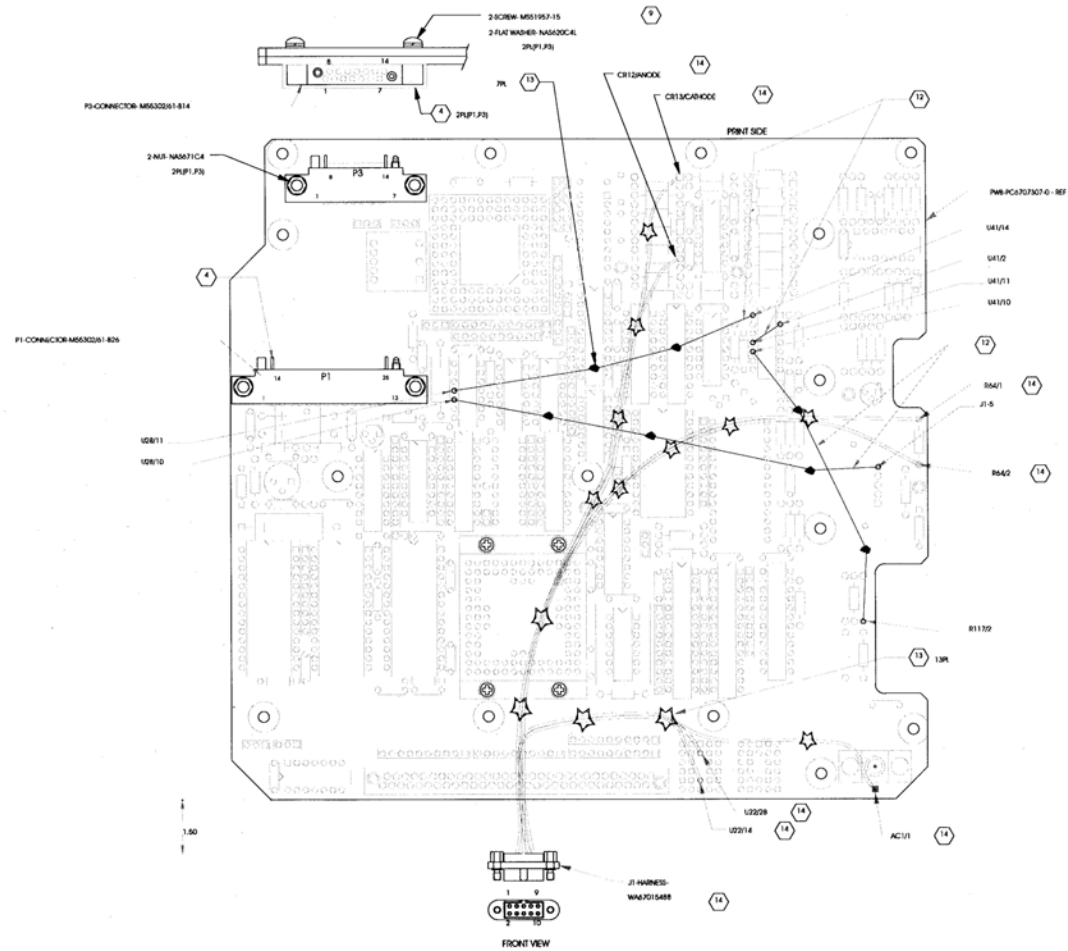

FO-3. MVP Processor CCA, PN AY6707288-0, Schematic Diagram (Sheet 3 of 4)



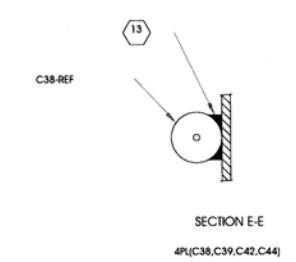
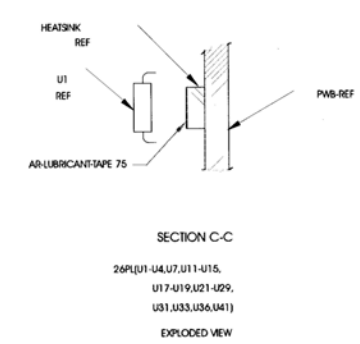
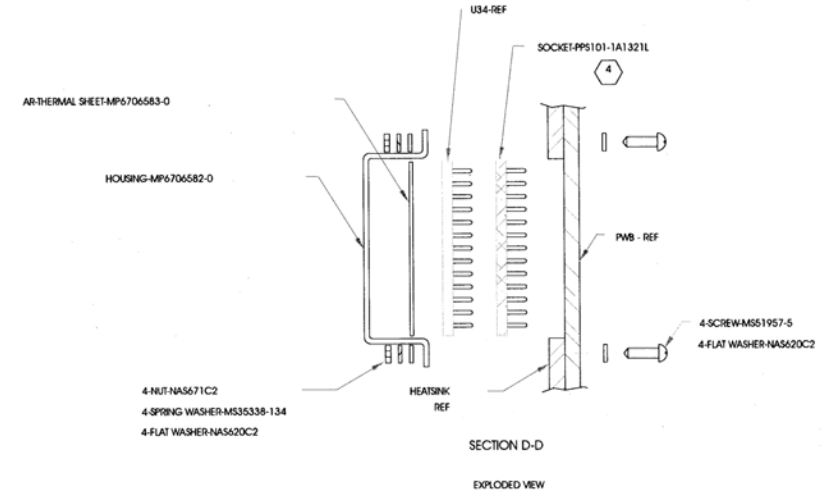
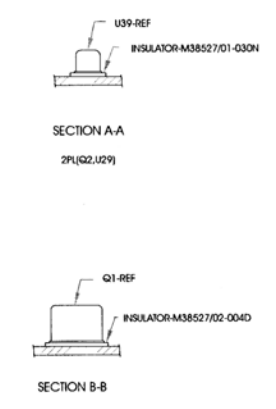

FO-3. MVP Processor CCA, PN AY6707288-0, Schematic Diagram (Sheet 4 of 4)



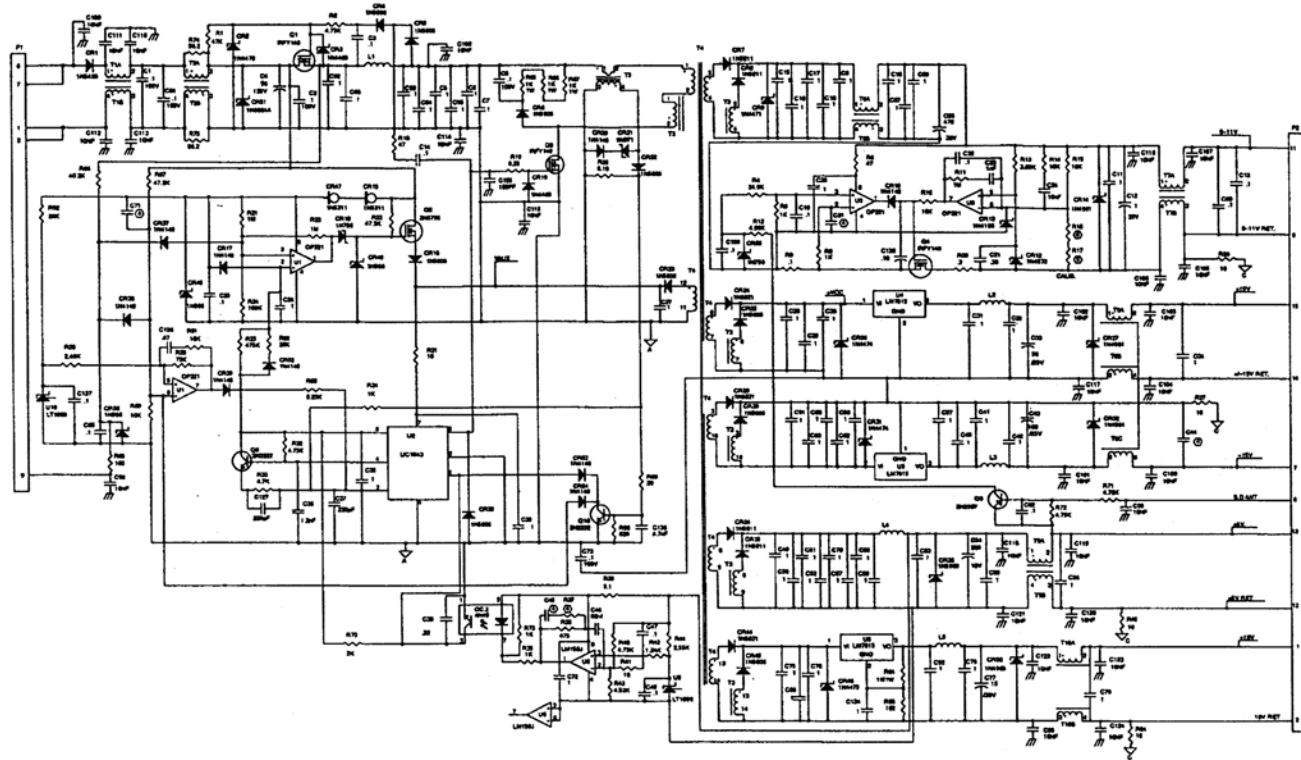

FO-4. Power Supply Module, PN AY6707291-0, Schematic Diagram



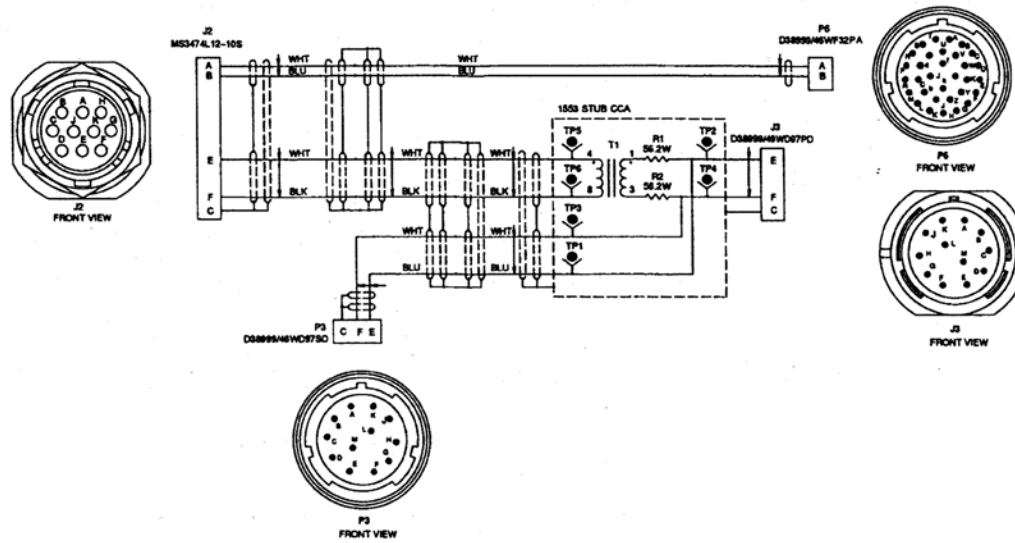

CMVS002/WP#70296-0

FO-5. Power and Data Cable W93A (5 meter), PN 12599005, Schematic Diagram





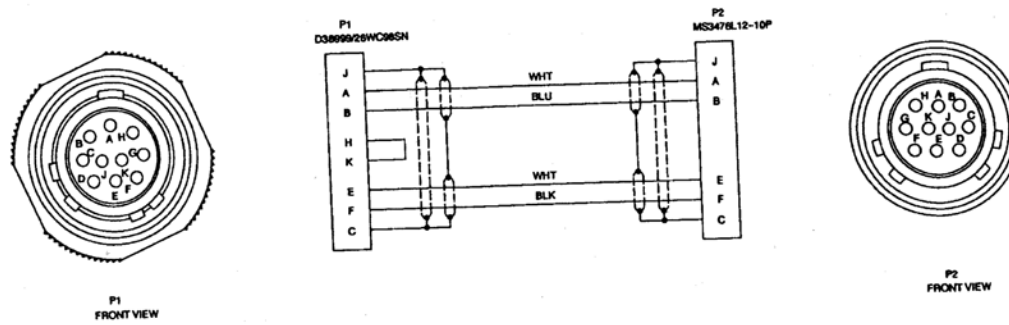

CMV5007/NA6707293-0

FO-6. Power and Data Cable W92 (0.75 meter), PN 12599004, Schematic Diagram



- NOTES:  
 1. APPLICABLE DOCUMENTS  
 A. MIL-STD-100E.  
 2. RESISTANCE VALUES ARE IN OHMS.  
 3. UNLESS OTHERWISE SPECIFIED  
 CAPACITANCE VALUES ARE IN MICROFARAD.  
 4. NOT ASSEMBLY.  
 5. FOR ASSEMBLY SEE DRAWING AY67010314 REV-A.

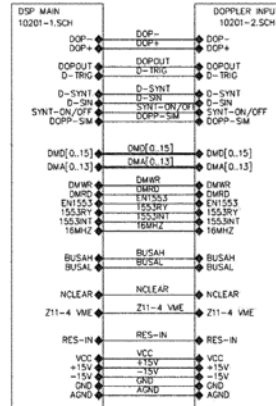

JUMPER INFORMATION	
DESCRIPTION	ASSEMBLED
JP1-U30 RS232 AND U5 B251 ASSEMBLED	JP1 1-2
JP1-U30 RS232 AND U5 B251 NOT ASSEMBLED	JP1 OPEN
JP2 MODE SEL: 1-2 TTL DOOPPLER 3-2 DIFF DOOPPLER	JP2:2-3
JP3 & JP6 No. OF WAIT STATES JP3 1-2 Max. JP6 1-2 2-3 Max.	JP3 N.C. JP6 1-2
JP4 SAMPLE IN1: 1-2:Fs 2-3:4MHz	JP4:1-2
JP7 ANALOG GND + DIGITAL GND	JP7:1-2
JP10 WATCH DOG TIME	JP10:N.C.
1553 RT ADDRESS = 6 JR10 JR11 JR12 JR13 JR14 JR1P	SHORT OPEN OPEN SHORT SHORT SHORT OPEN
1553 CONNECTION LONG STAB	JP8:1-2 JP9:1-2
1553 MODE VME JP12:OPEN JP11:1-2 MULTIBUS:JP12:1-2 JP11:2-3	JP12:2-3 JP9:2-3
JP13: OPEN AEROFLEX U42 ASSEMBLED	JP13:OPEN
JP13: 1-2 DOC U43 ASSEMBLED	JP13:OPEN
JP14: OPEN U42 OR U43 ASSEMBLED	JP14:OPEN
JP14: 1-2 U42 AND U43 NOT ASSEMBLED	JP14:OPEN
JP15: 1-2 U42 ASSEMBLED	JP15: 1-2
JP15: 2-3 U43 ASSEMBLED	JP15: 1-2
JP16	JP16:OPEN
JP17	JP17:OPEN

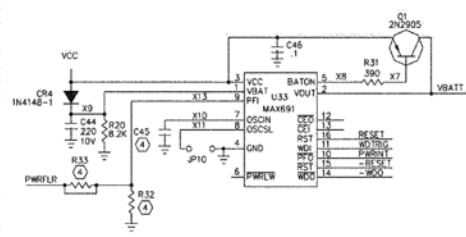
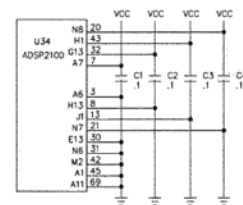
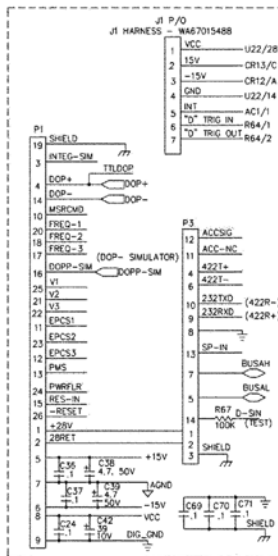
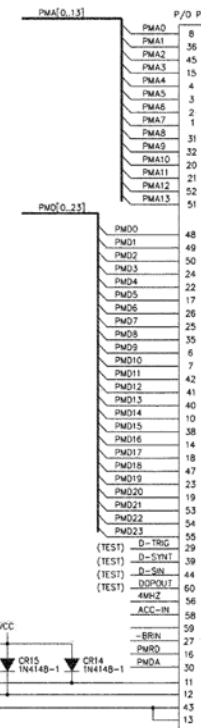

LD10201A1

FO-7. System Wiring Chart, PN LD61010201 (Sheet 1 of 3)

FO-19/(FO-20 blank)



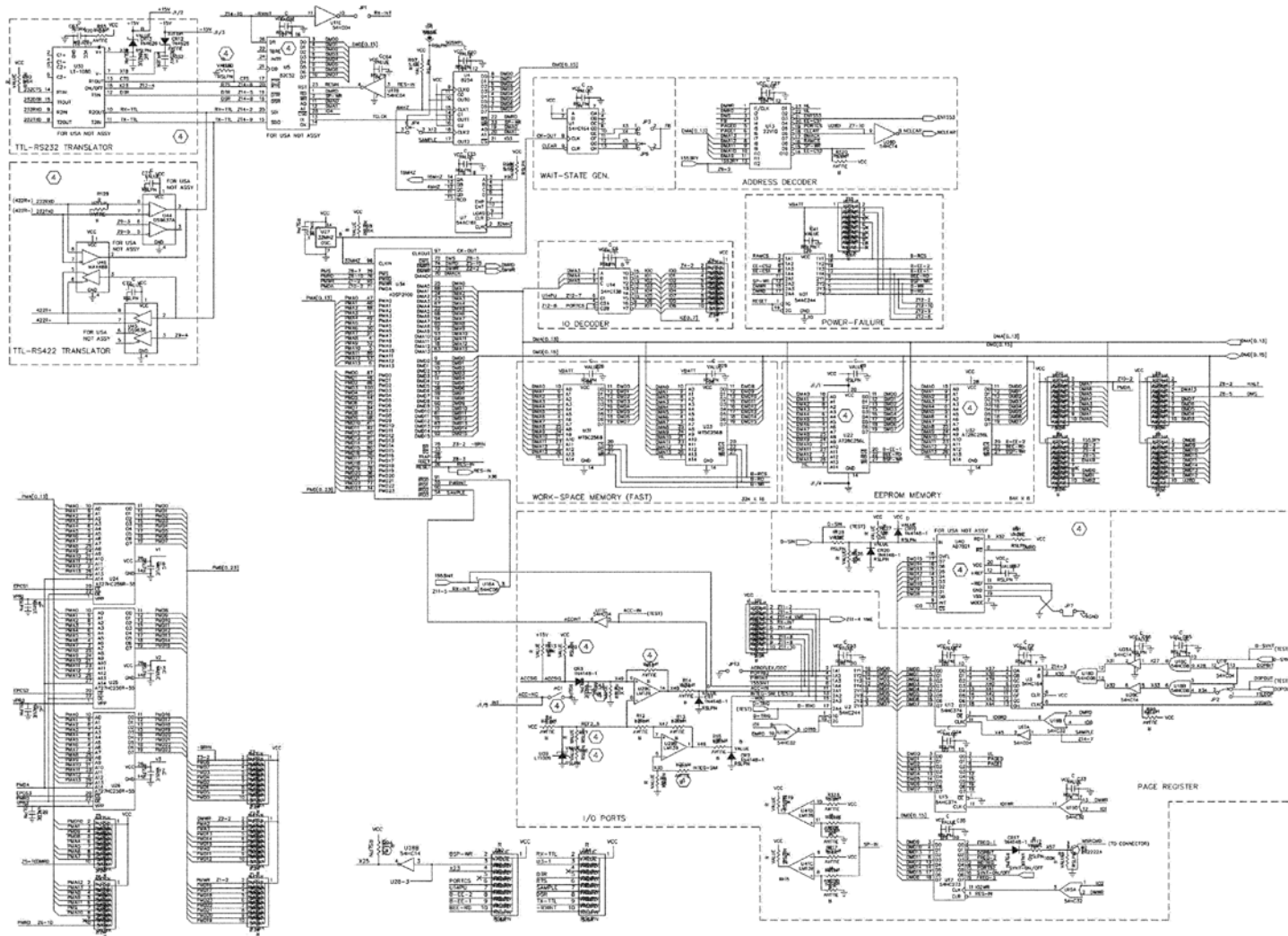

LD10201A2

FO-7. System Wiring Chart, PN LD61010201 (Sheet 2 of 3)

FO-21/(FO-22 blank)



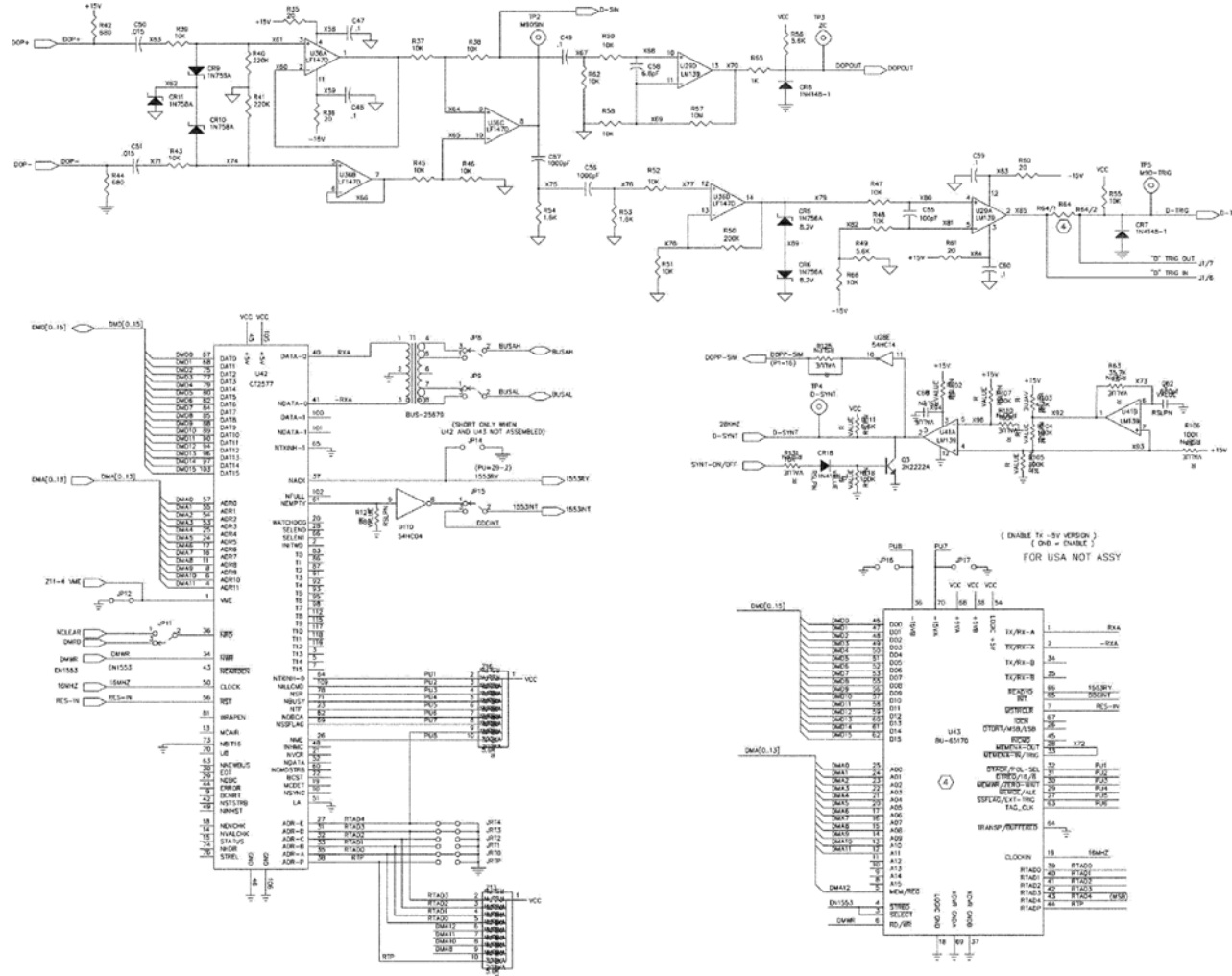

LD10201A3

FO-7. System Wiring Chart, PN LD61010201 (Sheet 3 of 3)

FO-23/(FO-24 blank)





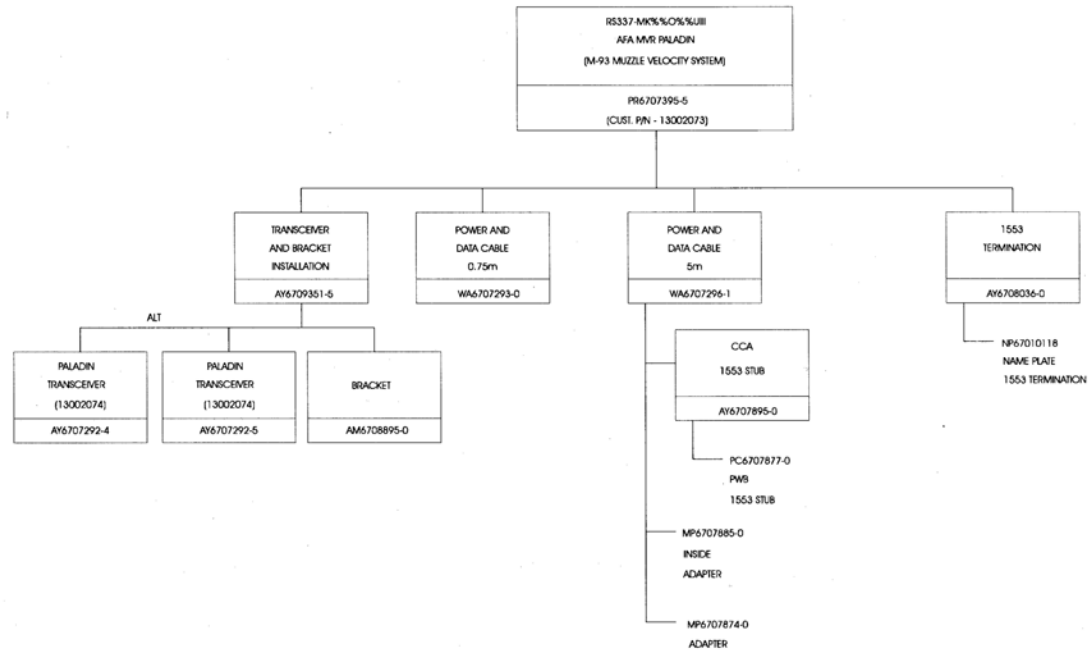

FO-8. M93 MVS Drawing Tree, PN RD7370-2C



NOTES:

1. ASSEMBLE AND FABRICATE PER COMPANY STANDARD # 905008094-G.
2. ACCEPTABILITY OF ELECTRONIC ASSEMBLIES PER PCA-A-610 CLASS LEVEL-3.
3. MARKING: RUBBER STAMP OR STENCIL PER SFA AND REV. USE MIL-STD-130 IN 3.20% AND 1.0 HIGH CHARACTERS USING CONTRASTING COLOR. INK TYPE %NON%NON%NON% MIL-4-43553.
4. DO NOT BEND OR CUT CONNECTOR P1 LEADS.
5. BEFORE CONFORMAL COATING BOND INDICATED COMPONENT TO BOARD USING ADHESIVE MMMA-134 EPOXY.
6. APPLY PRIMER MIL-S-22473 GRADE 1 AND SEALING COMPOUND MIL-S-22473 GRADE CV.
7. AFTER SOLDERING APPLY CONFORMAL COATING PER MIL-I-46058. TYPE AT ON BOTH SIDES OF CCA. COMPONENTS NOTED SHALL REMAIN FREE OF CONFORMAL COATING.
8. SOLDER OF ITEM INDICATED SHOULD BE AFTER SOLDERING COMPONENTS AND BOARD CLEANING SEE WIRE CONNECTION TABLE.

WIRE CONNECTION TABLE		(a)
FROM	TO POINT	
MC-1 RED	V	
MC-1 WHITE	S	
MC-1 BLACK	G	

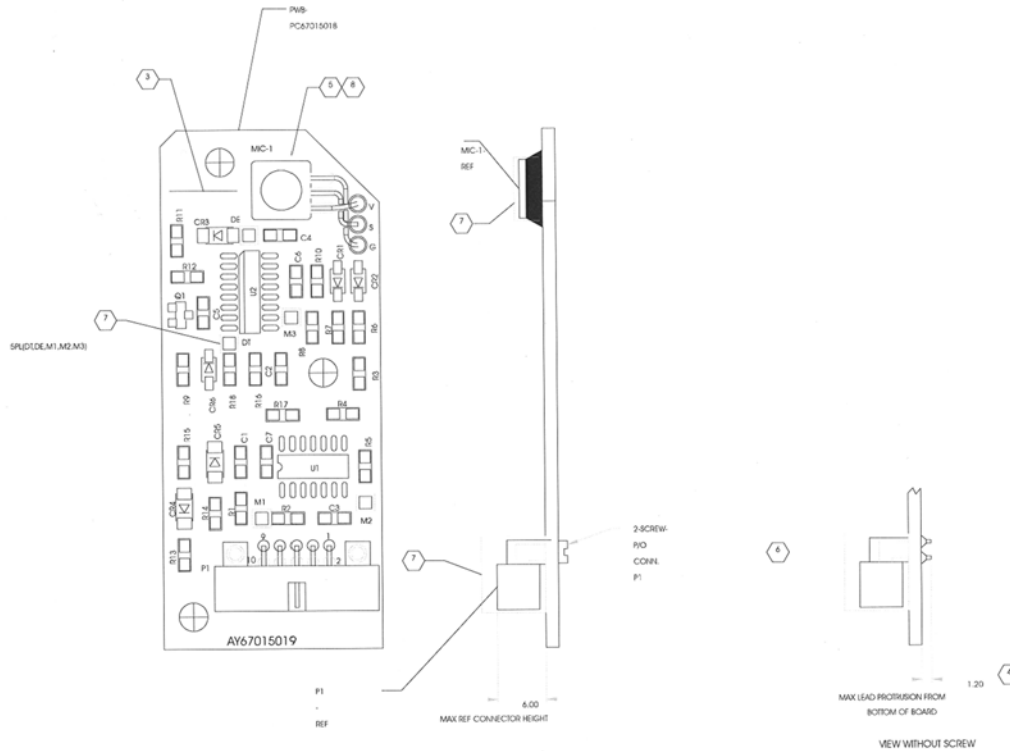

FO-9. Microphone Trigger CCA, PN AT67015019, Schematic Diagram (Sheet 1 of 2)



- NOTES:  
 1. APPLICABLE DOCUMENTS  
 A. MIL-STD-100E.  
 2. RESISTANCE VALUES ARE IN OHMS.  
 3. UNLESS OTHERWISE SPECIFIED  
 CAPACITANCE VALUES ARE IN MICROFARAD.  
 4. FOR ASSEMBLY SEE DRAWING AY67015019.

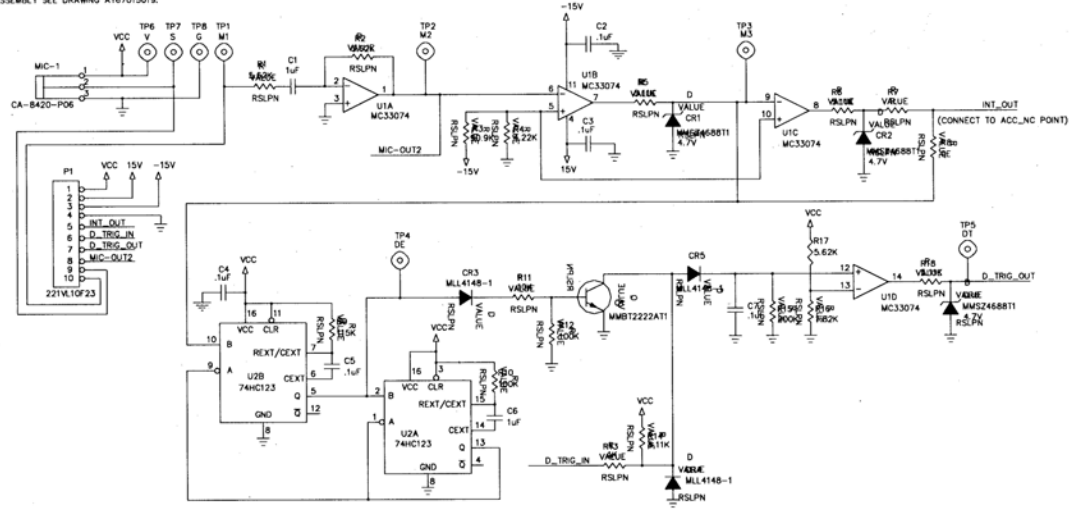

LD15019

FO-9. Microphone Trigger CCA, PN AT67015019, Schematic Diagram (Sheet 2 of 2)

PIN: 077972-000